



# Introduction to Architectural Science: The Basis of Sustainable Design



Steven V Szokolay



**Introduction to**  
**ARCHITECTURAL SCIENCE**  
**the basis of sustainable design**



**Introduction to**  
**ARCHITECTURAL SCIENCE**  
**the basis of sustainable design**

Steven V. Szokolay

Graphics assistance by  
Christopher Brisbin



ELSEVIER

AMSTERDAM • BOSTON • HEIDELBERG • LONDON • NEW YORK • OXFORD  
PARIS • SAN DIEGO • SAN FRANCISCO • SINGAPORE • SYDNEY • TOKYO

Architectural Press is an imprint of Elsevier



Architectural  
Press

Architectural Press  
An imprint of Elsevier Science  
Linacre House, Jordan Hill, Oxford OX2 8DP  
200 Wheeler Road, Burlington, MA 01803

First published 2004

Copyright © 2004, Steven Szokolay. All rights reserved

The right of Steven Szokolay to be identified as the author of this work has been asserted in accordance with the Copyright, Design and Patents Act 1988

All rights reserved. No part of this publication may be reproduced in any material form (including photocopying or storing in any medium by electronic means and whether or not transiently or incidentally to some other use of this publication) without the written permission of the copyright holder except in accordance with the provisions of the Copyright, Designs and Patents Act 1988 or under the terms of a licence issued by the Copyright Licensing Agency Ltd, 90 Tottenham Court Road, London, England W1T 4LP. Applications for the copyright holder's written permission to reproduce any part of this publication should be addressed to the publishers

**British Library Cataloguing in Publication Data**

Szokolay, Steven V.

Introduction to architectural science: the basis of sustainable design

1. Architectural design
2. Buildings — Environmental engineering
3. Sustainable architecture I. Title

721

**Library of Congress Cataloging in Publication Data**

A catalog record for this book is available from the Library of Congress

ISBN 0 7506 58495

For information on all Architectural Press publications visit our website at <a href="http://www.architecturalpress.com">www/architecturalpress/com</a>
---

Typeset by Newgen Imaging Systems (P) Ltd. Chennai, India

Printed and bound in Great Britain

# CONTENTS

Introduction	vii
List of examples	xi
List of figures	xiii
List of tables	xix
<b>PART 1 Heat: The Thermal Environment</b>	<b>1</b>
<b>PART 2 Light: The Luminous Environment</b>	<b>95</b>
<b>PART 3 Sound: The Sonic Environment</b>	<b>143</b>
<b>PART 4 Resources</b>	<b>191</b>
References	243
Bibliography	245
Data Sheets and Method Sheets	247
Appendix 1	317
Appendix 2	319
Index	321



# INTRODUCTION

Four chains of thought led to the idea of this book and to the definition of its content:

1. It can no longer be disputed that the resources of this earth are finite, that its capacity to absorb our wastes is limited, that if we (as a species) want to survive, we can't continue our ruthless exploitation of the environment. Where our actions would affect the environment, we must act in a sustainable manner. There are many good books that deal with the need for sustainability (e.g. Vale and Vale, 1991; Farmer, 1999; Roaf et al., 2001; Smith, 2001; Beggs, 2002). This book assumes that the reader is in agreement with these tenets and needs no further persuasion.
2. Architecture is the art and science of building. There exists a large literature on architecture as an art, on the cultural and social significance of architecture – there is no need for discussing these issues here.
3. The term 'bioclimatic architecture' was coined by Victor Olgyay in the early 1950s and fully explained in his book 'Design with climate' (1963). He synthesised elements of human physiology, climatology and building physics, with a strong advocacy of architectural regionalism and of designing in sympathy with the environment. In many ways he can be considered as an important progenitor of what we now call 'sustainable architecture'.
4. Architecture, as a profession is instrumental in huge investments of money and resources. Our professional responsibility is great, not only to our clients and to society, but also for sustainable development. Many excellent books and other publications deal with sustainable development in qualitative terms. However, professional responsibility demands expertise and competence. It is this narrow area where this work intends to supplement the existing literature.

The book is intended to give an introduction to architectural science, to provide an understanding of the physical phenomena we are to deal with and to provide the tools for realising the many good intentions. Many projects in recent times are claimed to constitute sustainable development, to be sustainable architecture. But are they really green or sustainable? Some new terms started appearing in the literature, such as 'green wash' – meaning that a conventional building is designed and then claimed to be 'green'. Or 'pure rhetoric – no substance', with the same meaning.



My hope is that after absorbing the contents of this modest work, the reader will be able to answer this question. After all, the main aim of any education is to develop a critical faculty.

Building environments affect us through our sensory organs:

1. The eye, i.e. vision, a condition of which is light and lighting; the aim is to ensure visual comfort but also to facilitate visual performance.
2. The ear, i.e. hearing: appropriate conditions for listening to wanted sound must be ensured, but also the elimination (or control) of unwanted sound: noise.
3. Thermal sensors, located over the whole body surface, in the skin; this is not just a sensory channel, as the body itself produces heat and has a number of adjustment mechanisms but it can function only within a fairly narrow range of temperatures and only an even narrower range would be perceived as comfortable. Thermal conditions appropriate for human well-being must be ensured.

What is important for the designer is to be able to control the indoor environmental conditions: heat, light and sound. Rayner Banham (1969) in his *Architecture of the well-tempered environment* postulated that comfortable conditions can be provided by a building (passive control) or by the use of energy (active control), and that if we had an unlimited supply of energy, we could ensure comfort even without a building. In most real cases it is a mixture (or synergy) of the two kinds of control we would be relying on.

In this day and age, when it is realised that our traditional energy sources (coal, oil, gas) are finite and their rapidly increasing use has serious environmental consequences (CO<sub>2</sub> emissions, global warming, as well as local atmospheric pollution), it should be the designer's aim to ensure the required indoor conditions with little or no use of energy, other than from ambient or renewable sources.

Therefore the designer's task is to:

1. examine the given conditions (site conditions, climate, daylight, noise climate);
2. establish the limits of desirable or acceptable conditions (temperatures, lighting and acceptable noise levels);
3. attempt to control these variables (heat, light and sound) by passive means (by the building itself) as far as practicable;
4. provide for energy-based services (heating, cooling, electric lighting, amplification or masking sound) only for the residual control task.

The building is not just a shelter, or a barrier against unwanted influences (rain, wind, cold), but the building envelope should be considered as a selective filter: to exclude the unwanted influences, but admit the desirable and useful ones, such as daylight, solar radiation in winter or natural ventilation.

The book consists of four parts: 1, Heat: the thermal environment; 2, Light: the luminous environment; 3, Sound: the sonic environment, and 4, Energy and resources. In each part, the relevant physical principles are reviewed, followed by a discussion of their relationship to humans (comfort and human requirements). Then the control functions of the building (passive controls) are examined as well as associated installations, energy-using 'active' controls. The emphasis is on how these can be considered in design. The first part (Heat) is the most substantial, as the thermal behaviour of a building has greatest effect on energy use and sustainability and its design is fully the architect's responsibility.



# LIST OF EXAMPLES

1.1	Jug to boil	6
1.2	Conduction heat flow	9
1.3	Resistive/capacitive layers	48
1.4	Insulation calculation	52
1.5	Thermal bridges	52
1.6	Solar gains/losses	54
1.7	Passive solar limit	57
1.8	Mass effect limits	59
1.9	Air movement effect limits	60
1.10	Condensation : process	70
1.11	Heat pumps: CoP calculation	80
1.12	Ventilation: duct size	93
2.1	Internally reflected component	118
2.2	Using the polar curves	132
2.3	Illuminance from a spotlight	133
2.4	Illuminance from a diffuser luminaire	133
2.5	Illuminance from a linear light source	133
2.6	Estimation: the Watt-method	134
2.7	Design of general lighting	136
3.1	Addition of sound levels	150
3.2	Spectral analysis for required insulation	168
3.3	The Haas-effect: delayed output	185



# LIST OF FIGURES

1.1	Temperature scale and interval	5
1.2	The full electromagnetic spectrum and its solar segment	8
1.3	Example wall section	9
1.4	Structure of the psychrometric chart	12
1.5	RH curves	12
1.6	Whirling psychrometer	13
1.7	WBT lines	13
1.8	Enthalpy lines	13
1.9	Specific volume	13
1.10	Heating/cooling	14
1.11	Cooling to reduce humidity	14
1.12	Humidification	14
1.13	Dehumidification	14
1.14	Full psychrometric chart	15
1.15	Stack effect	16
1.16	Cross ventilation	16
1.17	Body heat exchanges	16
1.18	Globe thermometer	18
1.19	Auliciems' thermal perception model	20
1.20	Bioclimatic chart	21
1.21	Comfort zones for Darwin & Budapest (a, b)	22
1.22	Section of the earth's orbit	23
1.23	Altitude and azimuth angles	23
1.24	Lococentric view of sun paths	23
1.25	Stereographic projection	24
1.26	Sun-paths vs latitudes	25
1.27	Example sun-path diagram	25
1.28	Irradiance and irradiation	26
1.29	Cosine law of incidence	26
1.30	Atmospheric depletion	26
1.31	Global wind pattern	27
1.32	Greenhouse effect	28
1.33	Climatic data table	29
1.34	Composite climate graph	30
1.35	Wind rose: monthly	30
1.36	Annual wind rose	31
1.37	Wind frequency analysis	31
1.38	Kelvin-hours	32
1.39	Four climate types	32
1.40	Protractor	35
1.41	VSA and mask	35
1.42	HSA and mask	36

xiv LIST OF FIGURES

1.43	VSA projection	36
1.44	Egg-crate device	37
1.45	Equinox cut-off (section + mask)	38
1.46	Design procedure	38
1.47	Transmission through glass	39
1.48	Sol-air temperature	39
1.49	Multidimensional heat flow: due to geometry	44
1.50	Multidimensional heat flow in mixed construction	44
1.51	Multidimensional heat flow: the 2 effects combined	44
1.52	The least resistance path	45
1.53	Heat flow 'downhill'	45
1.54	Thermal bridges: temperature distribution	45
1.55	Insulation over a column: flow paths	45
1.56	An element covered by thermal bridge bands	46
1.57	Periodic heat flow ( $\mu$ and $\phi$ )	46
1.58	$\mu$ and $\phi$ graphs	47
1.59	Time sequence	47
1.60	Sequence of layers (roof)	48
1.61	Plots of 4 climates	51
1.62	U-value modified by linear k	53
1.63	Trombe-Michel wall	56
1.64	CPZ: passive solar	57
1.65	A 'whole house' fan	58
1.66	CPZ: mass effect	59
1.67	CPZ: air movement	61
1.68	Evaporative cooler	61
1.69	Indirect evaporative cooler	62
1.70	CPZ: evaporative cooling	62
1.71	Aspect ratio	64
1.72	Sash types	65
1.73	Igloos	66
1.74	House of Socrates	67
1.75	Hot-dry climate house	68
1.76	Humid tropics house	70
1.77	Wing walls	70
1.78	Hybrid house	71
1.79	Condensation (psychrometric chart)	71
1.80	Katabatic wind	73
1.81	Wind velocity profiles	74
1.82	Rainfall on hills	74
1.83	Coastal winds	74
1.84	Urban heat island: rain	75
1.85	Local wind at one building	75
1.86	Cast iron stove	78
1.87	Ceramic stove	78
1.88	Balanced flue	79
1.89	Heat pump	80
1.90	Gas bottles	81

1.91	Oil storage	81
1.92	Domestic warm air system	82
1.93	Ring-main system	82
1.94	Two-pipe up-feed system	82
1.95	Two-pipe down-feed system	83
1.96	One-pipe system	83
1.97	Radiators	83
1.98	Convectors	84
1.99	H/W systems	85
1.100	Secondary H/W circulation	86
1.101	Solar hot water systems	87
1.102	A window a/c unit	88
1.103	A console a/c unit	88
1.104	A split system	88
1.105	A central air-handling unit	89
1.106	Four basic a/c systems	90
1.107	Storage effect on a/c load	91
1.108	Open cycle a/c: solid desiccant	91
1.109	Open cycle a/c: liquid desiccant	92
2.1	Framework of the CIE chromaticity chart	98
2.2	CIE chromaticity chart	98
2.3	Munsell colour-wheel	101
2.4	A simple luminous system	101
2.5	The steradian	102
2.6	Luminous efficacy curve	102
2.7	Interpretation of the inverse square law	102
2.8	The inverse square law	103
2.9	Transmission of light	104
2.10	Reflective surfaces	104
2.11	The human eye	105
2.12	Visual efficiency curve	106
2.13	Frequency distribution of outdoor illuminance	110
2.14	Interpretation of the vector/scalar ratio	110
2.15	Illuminance vectors in a side-lit room	111
2.16	Preferences for vector altitude	111
2.17	Preferred vector/scalar ratios	111
2.18	Assessment of overshadowing	112
2.19	A more involved case	113
2.20	Flux entering through a window	114
2.21	Daylight design diagram	115
2.22	Corrections for narrow windows and obstructions	115
2.23	Daylight flux split into three components	116
2.24	Determine initial sky component	116
2.25	Correction factor to sky component	117
2.26	Use of the IRC nomogram	119
2.27	Daylight factors at grid-points and DF contours	119



xvi LIST OF FIGURES

2.28	A back-lit translucent artificial sky	120
2.29	A reflective solid artificial sky	120
2.30	A mirror-type artificial sky	121
2.31	A study of daylight distribution	122
2.32	Construction of sun penetration: light patch on floor	123
2.33	Prismatic glass for beam sunlighting	124
2.34	Laser-grooved acrylic sheet	124
2.35	Laser-grooved roof light	124
2.36	External and internal light shelves	125
2.37	A fully enclosed light shelf with a reflective film	125
2.38	Heliostat for beam sunlighting	125
2.39	Beam sunlighting by heliostat and light pipes	126
2.40	A ceiling duct: 'anidolic' ceiling	126
2.41	A concentrator/optical fibre lighting system	126
2.42	Effect of inductive load: the current is delayed	127
2.43	A typical mercury lamp (160 W)	128
2.44	High pressure sodium lamp	128
2.45	Control circuit for a fluorescent lamp	128
2.46	A crown-silvered narrow-beam spotlight	130
2.47	Luminaire types and their flux fractions	131
2.48	A diffuser luminaire and its polar curve	132
2.49	An open trough luminaire and its polar curves	132
2.50	A compact fluorescent lamp	133
2.51	Spotlight on a horizontal surface	133
2.52	Diffuser lighting on a horizontal surface	133
2.53	Interpretation of flux installed and flux received	135
2.54	Interpretation of the direct ratio	135
2.55	Addition of vectors (the parallelogram of vectors)	141
2.56	Switching arrangement of rows for PSALI	141
3.1	Sound waves: longitudinal compression waves	145
3.2	Some typical sound spectra	147
3.3	Acoustic shadow and diffraction	148
3.4	Nomogram for adding sound levels	150
3.5	Equal loudness contours	151
3.6	Weightings of sound levels: A, B and C	151
3.7	The human ear	152
3.8	Presbycusis: loss of hearing with age	152
3.9	The range of audible sounds	153
3.10	A pure tone, a hiss and a rumble	153
3.11	Noise spectra from some typical sources	155
3.12	The NR (noise rating) curves	155
3.13	Rating of a high and a low frequency noise	156
3.14	Noise spectra in some indoor environments	157
3.15	Spectra of some typical outdoor noises	158
3.16	Directionality of some sources	158
3.17	Graphic sound level recording, with $L_{10}$ , $L_{50}$ and $L_{90}$	159

3.18	The effect of wind on a sound wavefront	161
3.19	The effect of daytime temperature gradient	162
3.20	The effect of temperature inversion at night	162
3.21	Sound transmission paths between two rooms	162
3.22	An example of expressing transmission two ways	163
3.23	Transmission graph: resonance and coincidence	164
3.24	Partial enclosure for sound control	166
3.25	A noise barrier and its reduction effect	167
3.26	Noise contours at roads: level, in cut, or elevated	167
3.27	A building as a barrier and its effect	167
3.28	Spectral analysis of required insulation	168
3.29	A noise control nomogram	170
3.30	Some 'floating floor' arrangements	170
3.31	A fully isolated construction: a floating room	171
3.32	Direct and reverberant sound in a room	172
3.33	Porous absorbers	173
3.34	Membrane type absorbers	173
3.35	A cavity resonator absorber	174
3.36	A perforated panel absorber	174
3.37a	Absorbent baffles in ducts	175
3.37b	Absorbent baffle between bathrooms	175
3.37c	An absorbent pelmet and a ventilator	175
3.37d	Absorbent lining of soffit and absorbent louvres	175
3.38	Chart recording of reverberation time	177
3.39	An echo and a flutter echo	178
3.40	Situations where echo could occur	178
3.41	Recommended minimum volume of auditoria	179
3.42	Basic issues for shape of auditoria	179
3.43	Sound received by audience: sectional considerations	179
3.44	Sound reinforcement by reflections	180
3.45	Concave shapes: risk of focusing	180
3.46	Acoustic shadow caused by balcony	180
3.47	Recommended RT for speech and music	181
3.48	Systems to provide variable absorption	181
3.49	Directionality of speakers at various frequencies	184
3.50	A column of speakers constrains sound vertically	184
3.51	A low level speaker system for sound reinforcement	185
3.52	A rotating disc time delay system	185
3.53	RT in the Royal Festival Hall, with and without ARS	186
3.54	A large reverberant room for absorption testing	187
3.55	Sound transmission test rooms	188
4.1	Resistive, capacitive and inductive loads	196
4.2	World energy supply by region	196
4.3	World primary energy production	197
4.4	History and forecast of oil production	197
4.5	World oil reserves and rate of production	198

xviii LIST OF FIGURES

4.6	System diagram of a nuclear power station	198
4.7	Flow of energy and matter in ecosystems	199
4.8	Generation of 3-phase electricity	201
4.9	Cogeneration in some countries	203
4.10a	A high solidity pumping windmill	204
4.10b	Propeller type wind generators	204
4.11a	The Savonius rotor	204
4.11b	The Darreius rotor	204
4.12	World wind generating capacity	205
4.13	World wind energy production	205
4.14	A methane generator for solid input	206
4.15	A methane generator for liquid input	206
4.16	A thermosiphon solar water heater	207
4.17	A pumped solar hot water system	207
4.18	A close-coupled solar water heater	207
4.19	Main types of passive solar systems	208
4.20	A solar space heating system	209
4.21	A solar powered air conditioning system	210
4.22	A solar heating system using air for heat transport	210
4.23	A field of parabolic troughs	211
4.24	A 'power tower' system: a field of mirrors	211
4.25	PV module production of the world	211
4.26	Principles of a HDR system	214
4.27	A consumer unit: fuses and circuit breakers	219
4.28	An electrical layout plan	220
4.29	Electrical location symbols	220
4.30	A gas service connection	221
4.31	Flue arrangements for gas heaters	221
4.32	The efficiency of electric motors	225
4.33	Combined supply header and fire reserve tank	230
4.34	A built in situ septic tank	232
4.35	A rotary aeration facility	233

# LIST OF TABLES

1.1	SI units	5
1.2	Conductivity correction factors	9
1.3	Steady state heat flow expressions	44
1.4	Expressions for heat flow swing	47
1.5	Winter design temperatures	77
1.6	Correction for intermittent heating	78
1.7	Types of electric heaters	79
2.1	Colour of light	97
2.2	Some typical photometric values	103
2.3	Recommended illuminances	106
2.4	Colour properties of tubular fluorescent lamps	129
2.5	Categories of colour rendering tasks	129
2.6	Lamp power required	134
2.7	Minimum E/L ratios to limit veiling reflections	139
3.1	Sound power of some sources	146
3.2	Standard octaves (in Hz)	147
3.3	Limits of community noise in residences	161
3.4	Spectral analysis in tabulated form	169
3.5	Electrical speaker power requirements (W/100 persons)	184
4.1	Multiple and sub-multiple prefixes in the SI	193
4.2	Some obsolete energy units still in use	194
4.3	Conversion efficiencies of various processes	200
4.4	Cost of electricity in various countries	201
4.5	Efficiency and emissions of generating systems	202
4.6	Share of renewables	204
4.7	Greenhouse emissions of DHW systems	207
4.8	Technologies and purposes of solar energy use	213
4.9	Growth of renewable electricity production	214
4.10	Energy consumption of the world	216
4.11	Energy use in some countries by main categories	216
4.12	Standard colours of electrical cables	219
4.13	Energy use and greenhouse emissions	227
4.14	Process energy requirements of materials	236
4.15	Embodied energy in some building materials	237
4.16	Building materials assessment system (BMAS)	238
4.17	Environmental rating of some materials	239
4.18	Limits of CO <sub>2</sub> emissions for greenhouse rating	241



# PART 1

## HEAT: THE THERMAL ENVIRONMENT

<b>1.1 Physics of heat</b>	<b>5</b>		
1.1.1 Heat and temperature	5		
1.1.2 Heat flow	7		
1.1.2.1 Conduction	8		
1.1.2.2 Convection	10		
1.1.2.3 Radiation	11		
1.1.3 Humid air: psychrometry	12		
1.1.4 Air flow	14		
<b>1.2 Thermal comfort</b>	<b>16</b>		
1.2.1 Thermal balance and comfort	16		
1.2.2 Factors of comfort	17		
1.2.3 Adjustment mechanisms	19		
1.2.4 Comfort indices, comfort zone	21		
<b>1.3 Climate</b>	<b>22</b>		
1.3.1 The sun	22		
1.3.1.1 Sun-path diagrams	24		
1.3.1.2 Solar radiation	25		
1.3.2 Global climate, greenhouse effect	26		
1.3.3 Elements of climates: data	28		
1.3.3.1 Wind data	30		
1.3.3.2 Derived data	31		
1.3.4 Classification of climates	33		
<b>1.4 Thermal behaviour of buildings</b>	<b>34</b>		
1.4.1 Solar control	35		
1.4.1.1 Shading design	35		
1.4.1.2 Radiation calculations	36		
1.4.1.3 Solar heat gain	37		
1.4.2 Ventilation	40		
1.4.3 Steady-state heat flow	41		
1.4.3.1 Conduction heat flow	41		
1.4.3.2 Insulation	42		
		1.4.3.3 Thermal bridges: multidimensional steady-state heat flow	44
		1.4.4 Dynamic response of buildings	45
		1.4.4.1 Thermal response simulation	49
		1.4.4.2 Application	49
		<b>1.5 Thermal design: passive controls</b>	<b>51</b>
		1.5.1 Passive control of heat flows	51
		1.5.1.1 Passive solar heating	55
		1.5.1.2 The mass effect	57
		1.5.1.3 Air movement	59
		1.5.1.4 Evaporative cooling	60
		1.5.2 Control functions of design variables	62
		1.5.2.1 Component heat flows	62
		1.5.2.2 Design variables	63
		1.5.3 Climatic design archetypes	66
		1.5.3.1 In cold climates	66
		1.5.3.2 In temperate climates	66
		1.5.3.3 In hot-dry climates	68
		1.5.3.4 Warm-humid climates	68
		1.5.4 Condensation and moisture control	70
		1.5.5 Microclimatic controls	73
		<b>1.6 Active controls: HVAC</b>	<b>76</b>
		1.6.1 Heating	76
		1.6.1.1 Local heating	77
		1.6.1.2 Central heating	81
		1.6.2 Hot water supply	83
		1.6.3 Ventilation and air conditioning	87
		1.6.3.1 Mechanical ventilation systems	87
		1.6.3.2 Air conditioning systems	88
		1.6.4 Open cycle cooling systems	91
		1.6.5 Integration/discussion	92

## Symbols and Abbreviations

		<b>units</b>			<b>units</b>
asg	alternating solar gain factor	-	ET*	new effective temperature	°C
b	breadth, thickness	m	G	global irradiance	W/m <sup>2</sup>
clo	unit of clothing insulation		GT	globe temperature	°C
dTe	sol-air excess temperature (difference)	K	H	enthalpy (heat content)	kJ/kg
er	evaporation rate	kg/h	HDD	heating degree-days	Kd
f	response factor	-	H <sub>L</sub>	latent heat content	kJ/kg
k	linear heat loss coefficient	W/m.K	H <sub>S</sub>	sensible heat content	kJ/kg
met	unit of metabolic heat (58.2W/m <sup>2</sup> )		HSA	horizontal shadow angle	°
mr	mass flow rate	kg/s	Htg	heating requirement	(kWh) Wh
p	pressure	Pa	INC	angle of incidence	°
pt	total atmospheric pressure	Pa	Kd	Kelvin days	Kd
pv	vapour pressure	Pa	Kh	Kelvin hours	Kh
pv <sub>S</sub>	saturation vapour pressure	Pa	L	length (linear thermal bridges)	m
q	building conductance (spec. heat loss rate)	W/K	LAT	geographical latitude angle	°
qa	total admittance	W/K	M	metabolic heat production	W
qc	envelope conductance	W/K	MRT	mean radiant temperature	°C
qv	ventilation conductance	W/K	N	number of air changes per hour	-
h	surface conductance	W/m <sup>2</sup> K	ORI	orientation angle	°
h <sub>c</sub>	convective surface conductance	W/m <sup>2</sup> K	Q	heat flux or heat flow rate	W
h <sub>r</sub>	radiative surface conductance	W/m <sup>2</sup> K	Qc	conduction heat flow rate	W
sM	specific mass (per floor area)	kg/m <sup>2</sup>	Qe	evaporative heat loss rate	W
sQ	swing in heat flow rate (from mean)	W	Qi	internal heat gain rate	W
sT	swing in temperature (from mean)	K	Qs	solar heat gain rate	W
t	time	hour	Qv	ventilation heat flow rate	W
v	velocity	m/s	R	resistance	m <sup>2</sup> K/W
vr	volume flow rate (ventilation rate)	m <sup>3</sup> /s, L/s	R <sub>a-a</sub>	air-to-air resistance	m <sup>2</sup> K/W
vR	vapour resistance	MPa.s.m <sup>2</sup> /g	R <sub>c</sub>	cavity resistance	m <sup>2</sup> K/W
y	year		Rd	radiation, radiated heat (from body)	W
A	area	m <sup>2</sup>	RH	relative humidity	%
AH	absolute humidity	g/kg	R <sub>s</sub>	surface resistance	m <sup>2</sup> K/W
ALT	solar altitude angle	°	R <sub>si</sub>	internal surface resistance	m <sup>2</sup> K/W
AZI	solar azimuth angle	°	R <sub>so</sub>	outside surface resistance	m <sup>2</sup> K/W
C	conductance	W/m <sup>2</sup> K	SD	standard deviation	
CDD	cooling degree-days	Kd	SET	standard effective temperature	°C
CoP	coefficient of performance	-	SH	saturation point humidity	g/kg
CPZ	control potential zone		SI	Système International (of units)	
Cd	conduction, conducted heat (from body)	W	T	temperature	°C
Cv	convection, convected heat (from body)	W	Tb	balance point (base~) temperature	°C
D	daily total irradiation	Wh/m <sup>2</sup> , MJ/m <sup>2</sup>	TIL	tilt angle	°
D <sub>v</sub>	daily total vertical irradiation	Wh/m <sup>2</sup> , MJ/m <sup>2</sup>	T <sub>i</sub>	indoor temperature	°C
DBT	dry bulb temperature	°C	Tn	neutrality temperature	°C
DEC	solar declination angle	°	T <sub>o</sub>	outdoor temperature	°C
DD	degree-days	Kd	T <sub>s</sub>	surface temperature	°C
Dh	degree-hours	Kh	T <sub>s-a</sub>	sol-air temperature	°C
DPT	dew-point temperature	°C	U	air-to-air (thermal) transmittance	W/m <sup>2</sup> K
DRT	dry resultant temperature	°C	V	volume	m <sup>3</sup>
E	radiant heat emission	W	VSA	vertical shadow angle	°
EnvT	environmental temperature	°C	WBT	wet bulb temperature	°C
Ev	evaporation heat transfer (from body)	W	Y	admittance	W/m <sup>2</sup> K
			α	absorptance, or thermal diffusivity	-
			δ	vapour permeability	μg/m.s.Pa

		<b>units</b>						<b>units</b>
$\varepsilon$	emittance	-	$\Delta p$	pressure difference				Pa
$\eta$	efficiency	-	$\Delta S$	rate of change in stored heat				W
$\theta$	solar gain factor	-	$\Delta T$	temperature diff., interval, or increment				K
$\theta_a$	alternating solar gain factor	-	<b>Subscripts to G and D:</b>					
$\kappa$	conductivity correction factor	-	first	b				beam~
$\lambda$	conductivity	W/m.K		d				diffuse~
$\mu$	decrement factor	-		r				reflected~
$\pi$	vapour permeance	$\mu\text{g}/\text{m}^2\cdot\text{s}\cdot\text{Pa}$	second	h				horizontal
$\rho$	density, or reflectance	$\text{kg}/\text{m}^3$		v				vertical
		or -		p				on plane p
$\tau$	transmittance	-	for G only	n				normal to
$\phi$	time lag	h						radiation
$\Sigma$	sum of ...							



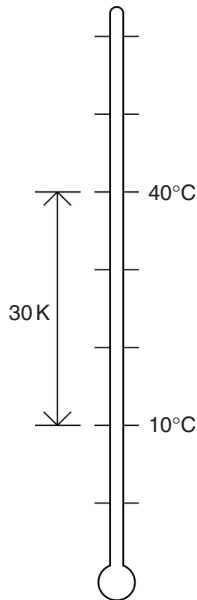


## 1.1 Physics of heat

### 1.1.1 Heat and temperature

**Heat** is a form of energy, contained in substances as molecular motion or appearing as electromagnetic radiation in space. Energy is the ability or capacity for doing work and it is measured in the same units. The derivation of this unit from the basic MKS (m, kg, s) units in the SI (Système International) is quite simple and logical, as shown in Table 1.1.

**Temperature** (T) is the symptom of the presence of heat in a substance. The Celsius scale is based on water: its freezing point taken as  $0^{\circ}\text{C}$  and its boiling point (at normal atmospheric pressure) as  $100^{\circ}\text{C}$ . The Kelvin scale starts with the 'absolute zero', the total absence of heat. Thus  $0^{\circ}\text{C} = 273.15^{\circ}\text{K}$ . The temperature interval is the same in both scales. By convention, a point on the scale is denoted  $^{\circ}\text{C}$  (degree Celsius) but the notation for a temperature difference or interval is K (Kelvin), which is a certain length of the scale, without specifying where it is on the overall scale (Fig. 1.1). Thus  $40^{\circ}\text{C} - 10^{\circ}\text{C} = 30\text{ K}$ , and similarly  $65^{\circ}\text{C} - 35^{\circ}\text{C}$  is 30 K, but  $15^{\circ}\text{C}$ , as a point on the scale, is  $288.15^{\circ}\text{K}$ .



**Fig. 1.1**  
Temperature scale and interval.

**Table 1.1** Derivation of composite SI units for thermal quantities

Length	m	(metre)
Mass	kg	(kilogram)
Time	s	(second)
Velocity, speed	<b>m/s</b>	i.e. unit length movement in unit time; the everyday unit is km/h, which is $1000\text{ m}/3600\text{ s} = 0.278\text{ m/s}$ or conversely: $1\text{ m/s} = 3.6\text{ km/h}$
Acceleration, force	<b>m/s<sup>2</sup></b>	i.e. unit velocity increase in unit time: (m/s)/s
	<b>kg.m/s<sup>2</sup></b>	that which gives unit acceleration to unit mass named newton ( <b>N</b> )
Work, energy	<b>kg.m<sup>2</sup>/s<sup>2</sup></b>	unit work is done when unit force is acting over unit length i.e. $\text{N} \times \text{m}$ named joule ( <b>J</b> )
Power, energy flow rate	<b>kg.m<sup>2</sup>/s<sup>3</sup></b>	unit energy flow in unit time or unit work done in unit time i.e. J/s named watt ( <b>W</b> )
Pressure, stress	<b>kg/m.s<sup>2</sup></b>	unit force acting on unit area ( $\text{kg.m/s}^2$ )/ $\text{m}^2$ i.e. $\text{N/m}^2$ named pascal ( <b>Pa</b> )

SI unit symbols, derived from personal names, are always capitalised.

## 6 INTRODUCTION TO ARCHITECTURAL SCIENCE

The **specific heat** concept provides the connection between heat and temperature. This is the quantity of heat required to elevate the temperature of unit mass of a substance by one degree, thus it is measured in units of **J/kg.K**. Its magnitude is different for different materials and it varies between 100 and 800 J/kg.K for metals, 800 and 1200 J/kg.K for masonry materials (brick, concrete) to water, which has the highest value of all common substances: 4176 J/kg.K (see data sheet D.1.1).

### Example 1.1

Given 0.5 L (=0.5 kg) of water at 20°C in an electric jug with an 800 W immersion heater element (efficiency: 1.0 or 100%).

How long will it take to bring it to the boil?

requirement:  $0.5 \text{ kg} \times 4176 \text{ J/kg.K} \times (100 - 20) \text{ K} = 167\,040 \text{ J}$

heat input 800 W i.e. 800 J/s, thus the time required is

$167\,040 \text{ J} / 800 \text{ J/s} = 208 \text{ s} \approx 3.5 \text{ min.}$

**Latent heat** of a substance is the amount of heat (energy) absorbed by unit mass of the substance at change of state (from solid to liquid or liquid to gaseous) without any change in temperature. This is measured in J/kg, e.g. for water:

– latent heat of fusion (ice to water) at 0°C = 335 kJ/kg

– latent heat of evaporation at 100°C = 2261 kJ/kg

at about 18°C = 2400 kJ/kg

At a change of state in the reverse direction the same amount of heat is released.

**Thermodynamics** is the science of the flow of heat and of its relationship to mechanical work.

The *first law* of thermodynamics is the principle of conservation of energy. Energy cannot be created or destroyed (except in sub-atomic processes), but only converted from one form to another. Heat and work are interconvertible. In any system the energy output must equal the energy input, unless there is a +/– storage component.

The *second law* of thermodynamics states that heat (or energy) transfer can take place spontaneously in one direction only: from a hotter to a cooler body, or generally from a higher to a lower grade state (same as water flow will take place only downhill). Only with an external energy input can a machine deliver heat in the opposite direction (water will move upwards only if it is pumped). Any machine to perform work must have an energy source and a sink, i.e. energy must flow through the machine: only part of this flow can be turned into work.

Heat flow from a high to a low temperature zone can take place in three forms: conduction, convection and radiation. The magnitude of any such flow can be measured in two ways:

- (a) as *heat flow rate* ( $Q$ ), or heat flux, i.e. the total flow in unit time through a defined area of a body or space, or within a defined system, in units of J/s, which is a watt (W). (The most persistent archaic energy flow rate or power unit is the *horsepower*, but in fully metric countries even car engines are now rated in terms of kW.)
- (b) as *heat flux density* (or density of heat flow rate), i.e. the rate of heat flow through unit area of a body or space, in  $W/m^2$ . The multiple kW (kilo-watt = 1000 W) is often used for both quantities. (The term 'density' as used here is analogous with e.g. population density: i.e. people per unit area, or with surface density: i.e. kg mass per unit area of a wall or other building element.)

A non-standard, but accepted and very convenient unit of energy is derived from this heat flux unit: the watt-hour (Wh). This is the amount of energy delivered or expended if a flow rate (flux) of 1 W is maintained for an hour.

As  $1 \text{ h} = 3600 \text{ s}$  and

$$1 \text{ W} = 1 \text{ J/s}$$

$$1 \text{ Wh} = 3600 \text{ s} \times 1 \text{ J/s} = 3600 \text{ J or } 3.6 \text{ kJ (kilojoule)}^\#.$$

The multiple kWh (kilowatt-hour) is often used as a practical unit of energy (e.g. in electricity accounts)

$$1 \text{ kWh} = 3\,600\,000 \text{ J or } 3600 \text{ kJ or } 3.6 \text{ MJ (megajoule)}.$$

### 1.1.2 Heat flow

As water flows from a higher to a lower position, so heat flows from a higher temperature zone (or body) to a lower temperature one. Such heat flow can take place in three forms:

1. *conduction* within a body or bodies in contact, by the 'spread' of molecular movement
2. *convection* from a solid body to a fluid (liquid or gas) or vice-versa (in a broader sense it is also used to mean the transport of heat from one surface to another by a moving fluid which, strictly speaking, is 'mass transfer'). The magnitude of

---

<sup>#</sup> for all prefixes used with SI units see Table 4.1 in Section 4.

## 8 INTRODUCTION TO ARCHITECTURAL SCIENCE

convection heat flow rate depends on

- (a) area of contact ( $A$ ,  $m^2$ ) between the body and the fluid
- (b) the difference in temperature ( $\Delta T$ , in K) between the surface of the body and the fluid
- (c) a convection coefficient ( $h_c$ ) measured in  $W/m^2K$ , which depends on the viscosity of the fluid and its flow velocity as well as on the physical configuration that will determine whether the flow is laminar or turbulent (see Section 1.1.2.2).

3. *radiation* from a body with a warmer surface to another which is cooler. Thermal radiation is a wavelength band of electromagnetic radiation, normally taken as  $700\text{ nm}^*$ – $10\,000\text{ nm}$  ( $10\ \mu\text{m}$ );\*\* ‘short infrared’  $700\text{--}2300\text{ nm}$  ( $2.3\ \mu\text{m}$ ); and ‘long infrared’  $2.3\text{--}10\ \mu\text{m}$  (some authors use  $70\ \mu\text{m}$  as the limit). The temperature of the emitting body determines the wavelength. The sun with its  $6000^\circ\text{C}$  surface emits short infrared (as well as visible and ultraviolet) radiation, bodies at terrestrial temperatures ( $<100^\circ\text{C}$ ) emit long infrared radiation. (Fig. 1.2 shows these bands in relation to the full electromagnetic spectrum.)

In all three forms the magnitude of flux (or of flux density) depends on the temperature difference between the points (or surfaces) considered, whilst the flux (heat flow rate) also depends on the cross-sectional area of the body available for conduction.

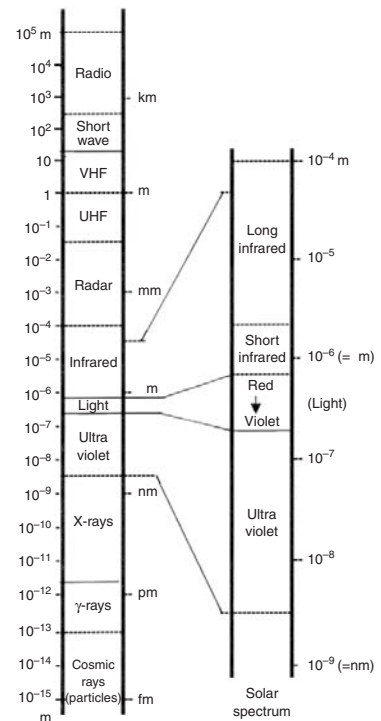
**1.1.2.1 Conduction** depends also on a property of the material known as *conductivity* ( $\lambda$ ), measured as the heat flow density ( $W/m^2$ ) in a 1-m thick body (i.e. the length of heat flow path is 1 m), with a one degree temperature difference, in units of  $W.m/m^2K = W/m.K$

Materials with low conductivity are referred to as insulating materials. These have a fibrous or porous structure and are very sensitive to moisture content. If the pores are filled with water, the conductivity will increase quite drastically. Take a porous, fibrous-cement insulating board:

	Density ( $kg/m^3$ )	Conductivity ( $W/m.K$ )
Dry	136	0.051
Wet	272	0.144
Soaked	400	0.203

Materials with a foam (closed pore) structure are not quite as sensitive.

Some conductivity values are given in data sheet D.1.1. Note that these are ‘declared values’, based on laboratory testing. The operational conditions in transportation and on building sites are such



**Fig. 1.2**  
The full electromagnetic spectrum and its solar segment.

\* 1 nm (nanometre) =  $10^{-9}\text{ m}$

\*\* 1  $\mu\text{m}$  (micrometre) =  $10^{-6}\text{ m}$

**Table 1.2** Conductivity correction factors

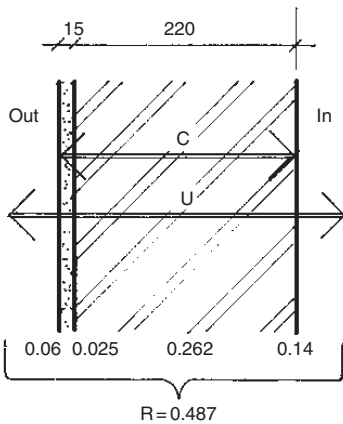
Material	Condition of use	$\kappa$
Expanded polystyrene	Between cast concrete layers	0.42
	Between masonry wall layers	0.10
	In ventilated air gap (cavity)	0.30
	With cement render applied	0.25
Mineral wool	Between masonry wall layers	0.10
Polyurethane	In ventilated air gap (cavity)	0.15

that damage to insulating materials is often inevitable, reducing their insulating properties. Before using such  $\lambda$  values for U-value calculations, they should be corrected by one or more conductivity correction factors:  $\kappa$  (kappa), which are additive:

$$\lambda_{\text{design}} = \lambda_{\text{declared}} \times (1 + \kappa_1 + \kappa_2 + \dots)$$

If from data sheet D.1.1, for EPS  $\lambda_{\text{declared}} = 0.035$  and it will be used as external insulation over a brick wall, with cement rendering applied directly to it (with a wire mesh insert), from Table 1.2:  $\kappa = 0.25$ , then

$$\lambda_{\text{design}} = 0.035 \times (1 + 0.25) = 0.0438 \text{ W/m.K.}$$



**Fig. 1.3**  
Example wall section: C and U and resistances which are additive.

Conductivity is a material property, regardless of its shape or size. The corresponding property of a physical body (e.g. a wall) is the *conductance* (C) measured between the two surfaces of the wall. For a single layer it is the conductivity, divided by thickness ( $\lambda/b$ ).<sup>†</sup> It is a rarely used quantity. *Transmittance*, or U-value includes the surface effects and it is the most frequently used measure. This is the heat flow density ( $\text{W/m}^2$ ) with 1 K temperature difference ( $\Delta T$ ) between air inside and air outside (see Fig. 1.3), in units of  $\text{W/m}^2\text{K}$ . For U-values see data sheets D.1.3 and D.1.4.

### Example 1.2

If the outside temperature is  $T_o = 10^\circ\text{C}$  and the inside is  $T_i = 22^\circ\text{C}$ , thus  $\Delta T = 10 - 22 = -12 \text{ K}$  (the negative indicating a heat loss)

over a  $10 \text{ m}^2$  brick wall ( $U = 1.5 \text{ W/m}^2\text{K}$ ) the heat flow rate will be

$$Q = A \times U \times \Delta T \quad (1.1)$$

$$Q = 10 \times 1.5 \times (-12) = -180 \text{ W}$$

<sup>†</sup> 'b' is used for thickness (breadth) to distinguish it from 't' for time and 'T' for temperature.

it is often useful to do a 'dimensional check' for such expressions:

$$\text{m}^2 \times \frac{\text{W}}{\text{m}^2\text{K}} \times \text{K} = \text{W}.$$

The reciprocal of the U-value is the air-to-air *resistance* ( $R_{a-a}$ , in  $\text{m}^2\text{K}/\text{W}$ ) which is the sum of component resistances: resistances of the surfaces and of the body of the element (wall, roof etc.), e.g. for a wall of two layers:

$$R_{a-a} = R_{si} + R_1 + R_2 + R_{so}. \quad (1.2)$$

The R-value of any homogeneous layer is its thickness ( $b$  for breadth) in  $m$ , divided by the conductivity of its material:

$$R = \frac{b}{\lambda}. \quad (1.3)$$

The reciprocal of this resistance is *conductance*,  $C$  in  $\text{W}/\text{m}^2\text{K}$ . Layers through which heat flows, can be represented as resistances in series, thus the resistances of layers are additive.

Various elements of an envelope are heat flow paths (with resistances) in parallel, and in this case the (area weighted) conductances (transmittances) are additive. For example, Fig. 1.3 shows a 220 mm brick wall ( $\lambda = 0.84 \text{ W}/\text{m}\cdot\text{K}$ ), with a 15 mm cement render ( $\lambda = 0.6 \text{ W}/\text{m}\cdot\text{K}$ ) and surface resistances of  $R_{si} = 0.14$  and  $R_{so} = 0.06 \text{ m}^2\text{K}\cdot\text{W}$  (values taken from data sheets D.1.1 and D.1.2).

$$R_{\text{body}} = \frac{0.220}{0.84} + \frac{0.015}{0.6} = 0.287 \text{ thus}$$

$$C = \frac{1}{R_{\text{body}}} = \frac{1}{0.287} = 3.484 \text{ W}/\text{m}^2\text{K}.$$

$$R_{a-a} = 0.14 + 0.287 + 0.06 = 0.487 \text{ thus}$$

$$U = \frac{1}{R_{a-a}} = \frac{1}{0.487} = 2.054 \text{ W}/\text{m}^2\text{K}.$$

The surface resistance depends on the degree of exposure and – to some extent – on surface qualities.

The surface resistance combines the resistances to convection and radiation, thus it is affected by radiation properties of the surface, as discussed below in the radiation section.

**1.1.2.2 Convection** heat transfer is a function of the *convection coefficient*,  $h_c$  (in  $\text{W}/\text{m}^2\text{K}$ )

$$\boxed{Q_v = A \times h_c \times \Delta T} \quad \text{m}^2 \times \text{W}/\text{m}^2\text{K} \times \text{K} = \text{W}. \quad (1.4)$$

The magnitude of  $h_c$  depends on the position of the surface, the direction of the heat flow and the velocity of the fluid. For example

- for vertical surfaces (horizontal heat flow)  $h_c = 3 \text{ W/m}^2\text{K}$
- for horizontal surfaces
  - heat flow up (air to ceiling, floor to room air)  $4.3 \text{ W/m}^2\text{K}$
  - heat flow down (air to floor, ceiling to room air)  $1.5 \text{ W/m}^2\text{K}$

(as hot air rises, the upward heat transfer is stronger)

In the above, still air is assumed (i.e. air flow is due to the heat transfer only). If the surface is exposed to wind, or mechanically generated air movement (i.e. if it is forced convection), then the convection coefficient is much higher:

- $h_c = 5.8 + 4.1 v$   
where  $v$  is air velocity in m/s.

**1.1.2.3 Radiation** heat transfer is proportional to the difference of the 4th power of absolute temperatures of the emitting and receiving surfaces and depends on their surface qualities, measured by non-dimensional numbers:

*reflectance* ( $\rho$ ) is a decimal fraction indicating how much of the incident radiation is reflected by a surface.

*absorptance* ( $\alpha$ ) is expressed as a fraction of that of the 'perfect absorber', the theoretical black body (for which  $\alpha = 1$ ), and its value is high for dark surfaces, low for light or shiny metallic surfaces. For everyday surfaces it varies between  $\alpha = 0.9$  for a black asphalt and  $\alpha = 0.2$  for a shiny aluminium or white painted surface. For any opaque surface  $\rho + \alpha = 1$ .

*emittance* ( $\epsilon$ ) is also a decimal fraction, a measure of the ability to emit radiation, relative to the 'black body', the perfect emitter. For an ordinary surface  $\alpha = \epsilon$  for the same wavelength (or temperature) of radiation, but many surfaces have selective properties, e.g. high absorptance for solar ( $6000^\circ\text{C}$ ) radiation but low emittance at ordinary temperatures ( $<100^\circ\text{C}$ ), e.g.:

$$\alpha_{6000} > \epsilon_{60}.$$

Such *selective surfaces* are useful for the absorber panels of solar collectors, but the reverse is desirable where heat dissipation (radiation to the sky) is to be promoted:

$$\alpha_{6000} < \epsilon_{60}.$$

White paints (especially a titanium oxide) have such properties. A shiny metal surface is non-selective:

$$\alpha_{6000} = \epsilon_{60}.$$



The calculation of radiant heat exchange is complicated, but it is quite simple for the effect which is most important for buildings: solar radiation. If the flux density of incident radiation is known (referred to as global irradiance,  $G$ ) than the radiant (solar) heat input rate would be:

$$Q_s = A \times G \times \alpha \quad \text{m}^2 \times \text{W/m}^2 \times \text{non-dim.} = \text{W.} \quad (1.5)$$

### 1.1.3 Humid air: psychrometry

(not to be confused with ‘psychometry’, which means psychological measurement; this one has an ‘r’ in the middle)

**Air** is a mixture of oxygen and nitrogen, but the atmosphere around us is humid air, it contains varying amounts of water vapour. At any given temperature the air can only support a limited amount of water vapour, when it is said to be saturated. Fig. 1.4 shows the basic structure of the psychrometric chart: dry bulb (air-) temperature on the horizontal axis and moisture content (or *absolute humidity*, AH) on the vertical axis (in units of g/kg, grams of moisture per kg of dry air).

The top curve is the *saturation line*, indicating the maximum moisture content the air could support at any temperature, which is the *saturation humidity* (SH). Each vertical ordinate can be subdivided (Fig. 1.5 shows a subdivision into 5 equal parts) and the curves connecting these points show the relative humidity (RH) in %, i.e. as a percentage of the saturation humidity. In this case the 20, 40, 60 and 80% RH curves are shown.

E.g. (with reference to Fig. 1.14, the full psychrometric chart) at 25°C the saturation AH is 20 g/kg. Halving the ordinate we get 10 g/kg, which is half of the saturation humidity or 50% RH.

Another expression of humidity is the vapour pressure ( $p_v$ ), i.e. the partial pressure of water vapour in the given atmosphere. The saturation vapour pressure is  $p_{v_s}$ .

$$\text{Thus } RH = (AH/SH) \times 100 \text{ or } (p_v/p_{v_s}) \times 100 \text{ (in \%)}.$$

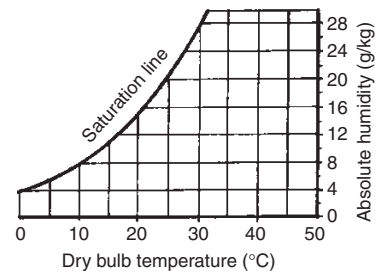
Vapour pressure is linearly related to AH and the two scales are parallel:

$$AH = \frac{622 * p_v}{p_t - p_v}$$

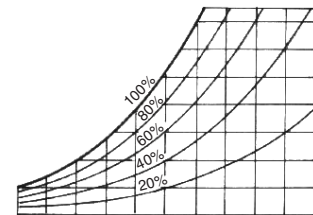
where  $p_t$  = total barometric pressure, taken as 101.325 kPa (kilo-Pascal) for the ‘standard atmosphere’.

E.g. if  $p_v = 2 \text{ kPa}$ ,  $AH = (622 \times 2)/(101.325 - 2) = 12.5 \text{ g/kg}$  (see Fig. 1.14).

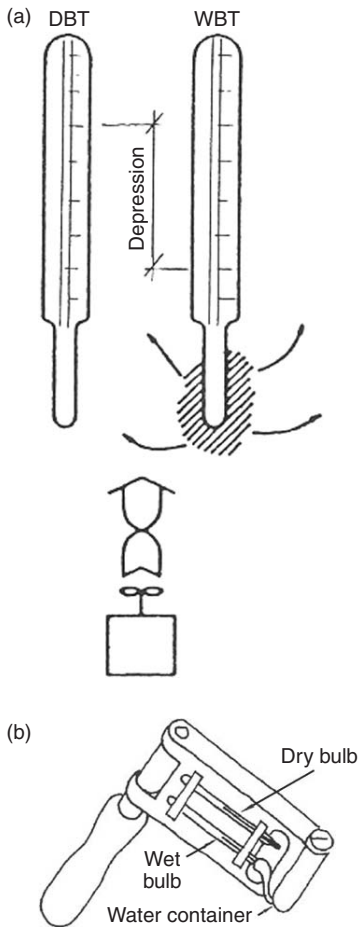
**Humidity** is best measured by the wet-and-dry bulb (whirling) *psychrometer* or an aspirated psychrometer (Fig. 1.6). These contain



**Fig. 1.4**  
Structure of the psychrometric chart.



**Fig. 1.5**  
Relative humidity curves.



**Fig. 1.6**  
Principles of an aspirated psychrometer (a) and a whirling psychrometer (b).

two thermometers. One has its bulb wrapped in a gauze which is kept moist from a small water container. When whirled around (or the fan is operated) to obtain maximum possible evaporation, this will show the *wet bulb temperature* (WBT). The other thermometer measures the air- or dry bulb temperature (DBT). The difference  $DBT - WBT$  is referred to as the *wet bulb depression* and it is indicative of the humidity. Evaporation from the wick has a cooling effect, which causes the wet bulb depression. Evaporation is inversely proportional to humidity. In saturated air there is no evaporation, no cooling, thus  $WBT = DBT$ . With low humidity there is strong evaporation, strong cooling and a large wet bulb depression.

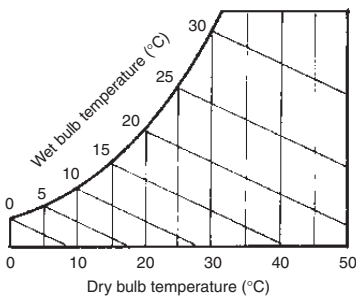
Fig. 1.7 shows the sloping WBT lines on the psychrometric chart. These coincide with the DBT at the saturation curve. When a measurement is made, the intersection of the DBT and WBT lines can be marked on the psychrometric chart; it will be referred to as the *status point*, which indicates both the RH (interpolated between the RH curves) and the AH values (read on the right-hand vertical scale).

E.g. (from Fig. 1.14) if  $DBT = 29^\circ C$  and  $WBT = 23^\circ C$  has been measured and plotted, the two lines intersect at the 60% RH curve and on the vertical scale the AH is read as just over 15 g/kg.

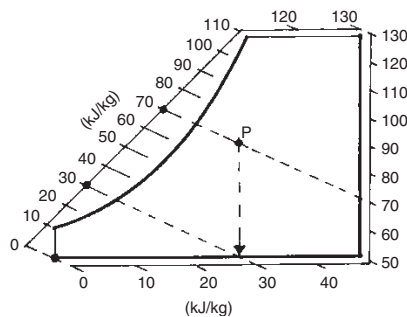
**Enthalpy (H)** is the heat content of the air relative to  $0^\circ C$  and 0 humidity. It is measured in kJ/kg, i.e. the heat content of 1 kg air. It has two components: *sensible heat*, ( $H_S$ ) taken up to increase the DBT (approx.  $1.005 \text{ kJ/kg.K}$ ) and *latent heat*, ( $H_L$ ) i.e. the heat that was necessary to evaporate liquid water to form the moisture content of the air. As the constant enthalpy lines almost coincide with the WBT lines (but not quite), to avoid confusion, it is indicated by duplicate scales on either side, outside of the body of the psychrometric chart, which are used with a straight edge (Fig. 1.8).

If enthalpy is the diagonal distance of the status point from the  $0^\circ C$  and 0 RH point, then the horizontal component is the  $H_S$  and the vertical component is the  $H_L$ .

**Specific volume** of air at any condition is also shown on the chart by a set of steeply sloping lines (Fig. 1.9). This is the volume



**Fig. 1.7**  
Wet bulb temperature lines.



**Fig. 1.8**  
Enthalpy scales externally.



**Fig. 1.9**  
Specific volume lines.

of air occupied by 1 kg of air (at normal pressure), in  $m^3/kg$ . It is the reciprocal of density,  $kg/m^3$ .

**Psychrometric processes** or changes can be traced on the chart. *Heating* is represented by the status point moving horizontally to the right. As the DBT increases, with no change in moisture content, the relative humidity is reducing (Fig. 1.10).

*Cooling* lowers the DBT, the status point moves horizontally to the left. This causes the RH to increase, but the AH is not changed. Where this horizontal line reaches the saturation curve, the *dew-point temperature* (corresponding to the given AH) can be read. For the above example this will be at about  $20.5^\circ C$ . At this point the RH will be 100%. If the air is cooled below this point, condensation will start, dew will be formed. Below the dew point the status point moves along the saturation curve and the absolute humidity corresponding to the vertical drop will have condensed out.

Continuing the above example, the  $29^\circ C$  air of  $15.2 g/kg$  AH (60% RH) has its dew-point at  $20.5^\circ C$ , and if it is cooled to (say)  $15^\circ C$ , at this point its (saturated) AH would be  $10.5 g/kg$ , so the difference of  $15.2 - 10.5 = 4.7 g/kg$  will have condensed out in liquid form (Fig. 1.11).

*Humidification*, i.e. evaporation of moisture into an air volume is said to be adiabatic, if no heat is added or removed. This causes a reduction of temperature (DBT) but an increase of humidity (both AH and RH). The status point moves up to the left, along a constant WBT line (Fig. 1.12)

*Adiabatic dehumidification* takes place when air is passed through some chemical sorbent (solid, such as silica gel, or liquid, such as glycol spray) which removes some of the moisture content (by absorption or adsorption). This process releases heat, thus the DBT will increase, whilst the humidity (both AH and RH) is reduced (Fig. 1.13).

### 1.1.4 Air flow

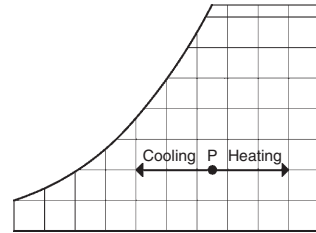
Air flow can be characterised by

- velocity  $v$  m/s
- mass flow rate  $m_r$  kg/s
- volume flow rate  $v_r$   $m^3/s$  or L/s

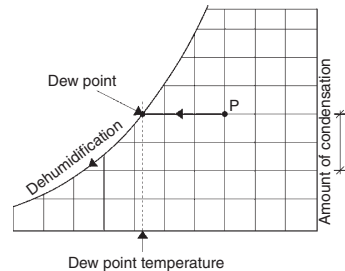
Air flow through an opening of A area is  $v_r = v \times A$

Natural air flow is caused by pressure difference: it will flow from a zone of high pressure towards a zone of low pressure. Pressure differences may be due to two effects:

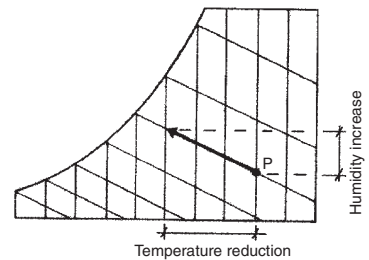
**Stack effect** occurs when the air inside a vertical stack is warmer than the outside air (provided that there are both inlet and outlet openings). The warmer air will rise and will be replaced at the bottom of the stack by cooler outside air. A good example of this is a chimney flue: when heated, it will cause a considerable 'draught'.



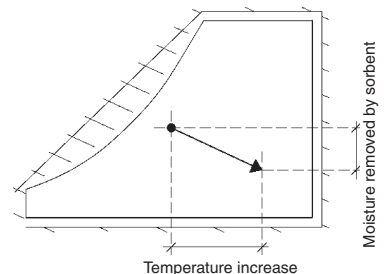
**Fig. 1.10**  
Cooling and heating: movement of the status point.



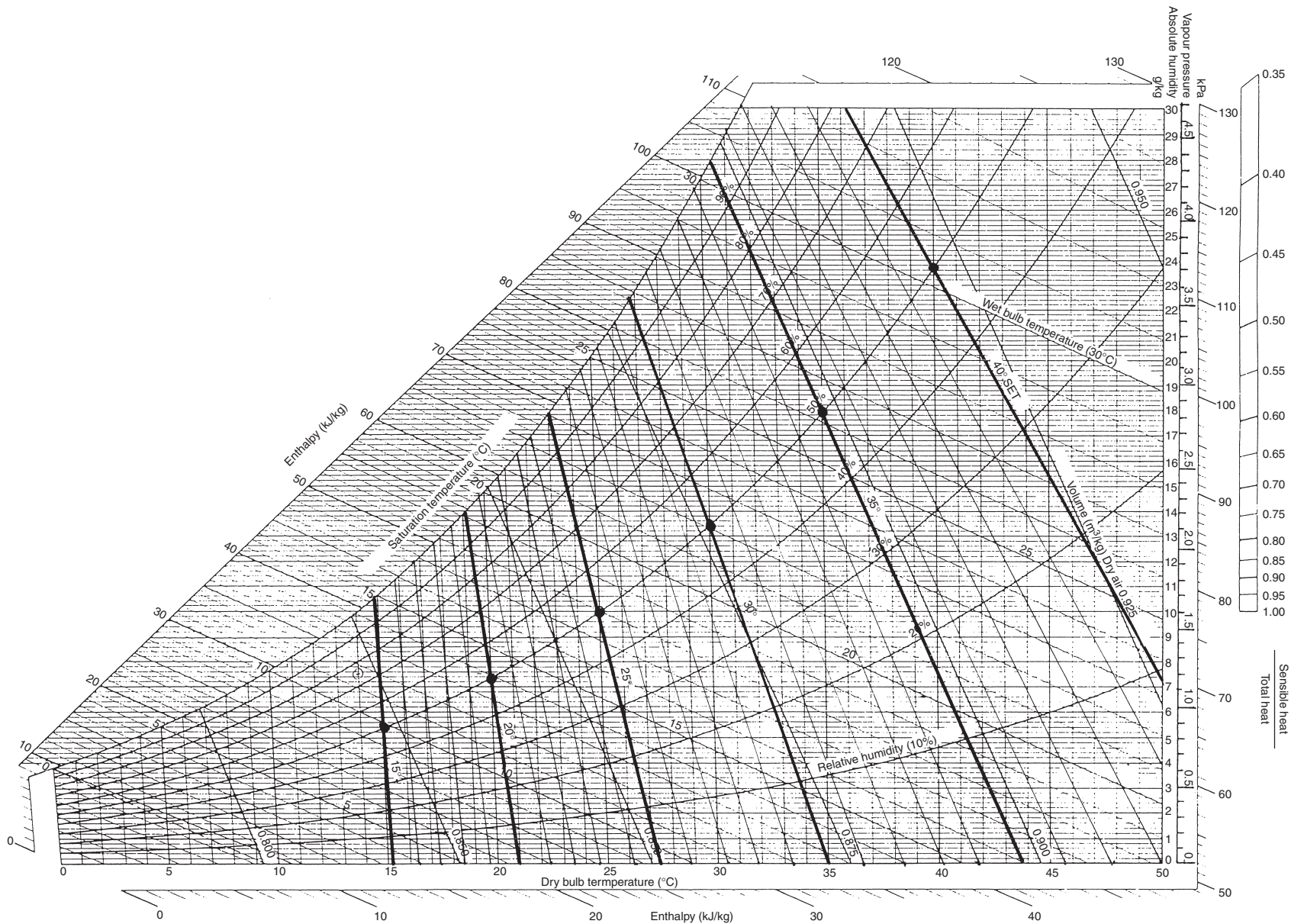
**Fig. 1.11**  
Cooling to reduce humidity.



**Fig. 1.12**  
Evaporative cooling: humidification.



**Fig. 1.13**  
Adiabatic dehumidification.



**Fig. 1.14**  
The psychrometric chart, with SET lines superimposed (after Szokolay, 1980).

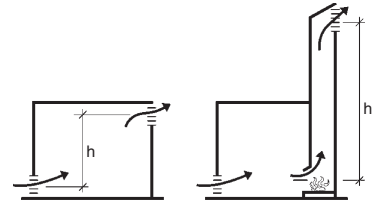
Ventilating shafts are often used for internal bathrooms or toilets, which are quite successful in a cool climate.

Stack effect can also occur within a room of significant height, if it has both a high level outlet and a low level inlet. The air flow will be proportional to the height difference between inlet and outlet openings and to the temperature difference between the air within the stack (or room air) and the outdoor air (Fig. 1.15). In low-rise buildings such stack effects are quite small, but – for example – in the staircase of a multistorey building it can develop into a howling gale. In warm climates the outdoor air may be just as warm as the stack air, so there will be no air flow, or if the stack air is cooler, it can produce a down-draft.

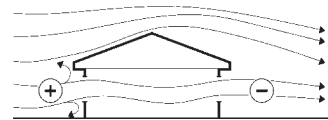
A special case that could be considered as an ‘enhanced stack effect’ is the *solar chimney*, where at least one side of the stack is exposed to solar radiation and has a high absorptance. This will be heated. It heats the air inside, thus the inside–outside temperature difference is increased, which in turn would increase the air flow.

**Wind effects** are normally much more powerful. On the windward side of a building a positive pressure-field will develop, where the pressure is proportional to the square of the velocity. At the same time a negative (reduced) pressure field may develop on the leeward side and the difference between the two pressures can generate quite a strong cross-ventilation (Fig. 1.16).

Method sheet M.1.2 gives methods of estimating the air flow that would result from stack and wind effects.



**Fig. 1.15**  
Stack effect in a room and in a chimney.



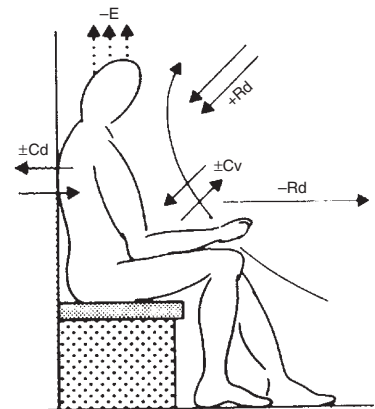
**Fig. 1.16**  
Wind effect: cross ventilation.

## 1.2 Thermal comfort

### 1.2.1 Thermal balance and comfort

The human body continuously produces heat by its metabolic processes. The heat output of an average body is often taken as 100 W, but it can vary from about 70 W (in sleep) to over 700 W in heavy work or vigorous activity (e.g. playing squash). This heat must be dissipated to the environment, or else the body temperature will increase. This deep-body temperature is normally about 37°C, whilst the skin temperature can vary between 31 and 34°C.

The body’s thermal balance can be expressed as (see Fig. 1.17)



**Fig. 1.17**  
Heat exchanges of the human body.

$$M \pm Rd \pm Cv \pm Cd - Ev = \Delta S \quad (1.6)$$

where

$M$  = metabolic heat production

$R_d$  = net radiation exchange

$C_v$  = convection (incl. respiration)

$C_d$  = conduction

$E_v$  = evaporation (incl. in respiration)

$\Delta S$  = change in stored heat.

A condition of equilibrium is that the sum (i.e. the  $\Delta S$ ) is zero and such equilibrium is a precondition of thermal comfort. However, comfort is defined as 'the condition of mind that expresses satisfaction with the thermal environment, it requires subjective evaluation'. This clearly embraces factors beyond the physical/physiological.

### 1.2.2 Factors of comfort

The variables that affect heat dissipation from the body (and thus also thermal comfort) can be grouped into three sets:

Environmental	Personal	Contributing factors
Air temperature	Metabolic rate (activity)	Food and drink
Air movement	Clothing	Body shape
Humidity	State of health	Subcutaneous fat
Radiation	Acclimatisation	Age and gender

Air temperature is the dominant environmental factor, as it determines convective heat dissipation. Air movement accelerates convection, but it also changes the skin and clothing surface heat transfer coefficient (reduces surface resistance), as well as increases evaporation from the skin, thus producing a physiological cooling effect. This can be estimated by Eq. (1.21), given in Section 1.4.2. Subjective reactions to air movement are:

<0.1 m/s	stuffy
to 0.2	unnoticed
to 0.5	pleasant
to 1	awareness
to 1.5	draughty
>1.5	annoying.

but under overheated conditions air velocities up to 2 m/s may be welcome.

Medium humidities (RH 30% to 65%) do not have much effect, but high humidities restrict evaporation from the skin and in respiration, and thus curb the dissipation mechanism, whilst very low humidities lead to drying out of the mucous membranes (mouth, throat) as well as the skin, thus causing discomfort.



Radiation exchange depends on the temperature of surrounding surfaces, measured by the MRT, or mean radiant temperature. This is the average temperature of the surrounding surface elements, each weighted by the solid angle it subtends at the measurement point.

The unit of solid angle is the steradian (sr), that is subtended by unit area ( $r^2$ ) of the surface at the centre of a sphere of unit radius ( $r$ ) (see also Fig. 2.5). As the surface area is  $4\pi r^2$ , the centre point will have a total of  $4\pi$  sr (per analogiam: the radian is an angular measure, a unit where the arc length is equal to the radius; as the circumference of a circle is  $2\pi r$ , the complete circle is  $2\pi$  radians)

The MRT cannot be measured directly, only by a black globe thermometer, which responds to radiant inputs as well as to air temperature. This may be a 150-mm diameter copper ball, painted matt black, with a thermometer at its centre (Fig. 1.18), but recently matt black painted ping pong balls have been used to measure the GT, to the same effect. When the air velocity is zero,  $MRT = GT$  but there is a correction for air movement:

$$MRT = GT * (1 + 2.35\sqrt{v}) - 2.35 * DBT \sqrt{v}$$

where  $v$  = air velocity in m/s. The effect of this MRT depends on clothing. In warm climates (with light clothing) it is about twice as significant as the DBT, which gives rise to the

$$\text{environmental temperature: } EnvT = \frac{2}{3}MRT + \frac{1}{3}DBT$$

but in cooler climates (people with heavier clothing) it has about the same influence as the DBT, hence the

$$\text{dry resultant temperature: } DRT = \frac{1}{2}MRT + \frac{1}{2}DBT.$$

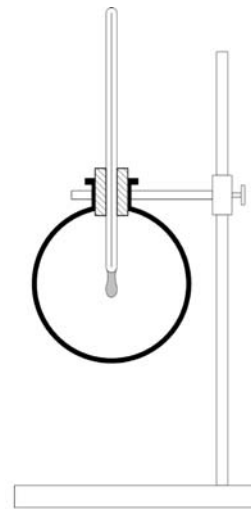
At or near comfort levels the difference between DBT and MRT should not be greater than about 3 K.

Metabolic rate is a function of activity level. The unit devised for this is the *met*, which corresponds to  $58.2 \text{ W/m}^2$  of body surface area (see also D.1.8).

Du Bois (1916) proposed the equation for body surface area (the Du Bois area) as:  $A_D = 0.202 \times M^{0.425} \times h^{0.725}$ , where  $M$  is body mass (kg) and  $h$  is height (m). For a man of  $M = 80 \text{ kg}$ ,  $h = 1.8 \text{ m}$ , this area is  $2 \text{ m}^2$ .

For an average person this would be about 115 W. With higher levels of *met* a cooler environment will be preferred, to facilitate the heat dissipation.

Clothing is thermal insulation of the body. It is measured in units of *clo*, which means a U-value of  $6.45 \text{ W/m}^2\text{K}$  (or a resistance of  $0.155 \text{ m}^2\text{K/W}$ ) over the whole body surface. 1 *clo* corresponds to a



**Fig. 1.18**  
Globe thermometer.

3-piece business suit, with cotton underwear. Shorts and short-sleeved shirts would give about 0.5 clo, an overcoat may add 1 or 2 clo units to a business suit and the heaviest type of arctic clothing would be some 3.5 clo (see Section 1.2.4). If clothing can be freely chosen, it is an important adjustment mechanism, but if it is constrained (e.g. by social conventions or work safety) in a warm environment, it should be compensated for by a cooler air temperature. Acclimatisation and habit (being used to . . .) is a strong influence, both physiologically and psychologically.

Food and drink habits may have an influence on metabolic rates, and thus have an indirect effect on thermal preferences. These effects may be changing in time, depending on food and drink intake. Body shape is significant in that heat production is proportional to body mass, but heat dissipation depends on body surface area. A tall and skinny person has a larger surface-to-volume ratio, can dissipate heat more readily, and can tolerate warmer temperatures than a person with a more rounded body shape. This effect is increased by the fact that subcutaneous fat is a very good insulator, and will thus lower the preferred temperatures.

At one stage it has been suggested that females prefer about 1 K warmer temperatures than males, but recently this difference has been attributed to differing clothing habits. Age does not make much difference in preferred temperature, but older people have less tolerance for deviations from the optimum, probably because their adjustment mechanisms are impaired.

### 1.2.3 Adjustment mechanisms

The body is not purely passive, it is *homeothermic*; it has several thermal adjustment mechanisms. The first level is the vasomotor adjustments: *vasoconstriction* (in a cold environment) will reduce the blood flow to the skin, reduce skin temperature, reduce heat dissipation; *vasodilation* (in a warm situation) will increase blood flow to the skin, thus the heat transport, elevate the skin temperature and increase heat dissipation.

If, in spite of the appropriate vasomotor adjustment there remains an imbalance, in a warm environment sweat production will start, providing an evaporative cooling mechanism. The sustainable sweat rate is about 1 L/h, which absorbs about 2.4 MJ/L of body heat (which constitutes a cooling rate of some 660 W). If this is insufficient, *hyperthermia* will set in, which is a circulatory failure. The body temperature may reach 40°C and heat stroke may occur.

Conversely, in a cold environment shivering will start, which is involuntary muscular work, increasing the heat production by up to a factor of 10. If this cannot restore equilibrium, *hypothermia* would set in, with possible fatal consequences.



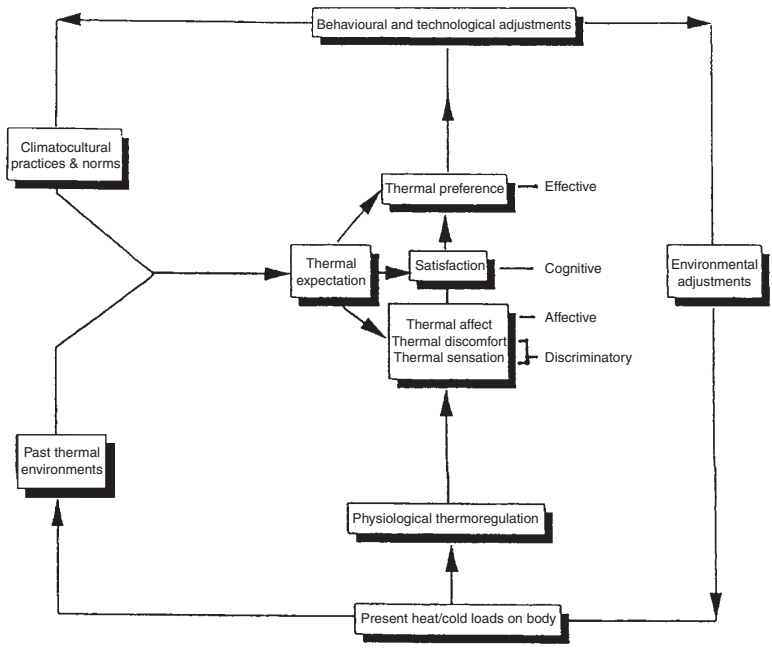
There are also longer-term adjustments, after a few days of exposure, up to about six months. It may involve cardiovascular and endocrine adjustments. In a hot climate this may consist of increased blood volume, which improves the effectiveness of vasodilation, enhanced performance of the sweat mechanism, as well as the readjustment of thermal preferences. Under continued underheated conditions the vasoconstriction may become permanent, with reduced blood volume, whilst the body metabolic rate may increase. These adjustments are however not only physiological, there is a strong psychological aspect as well: getting used to the dominant conditions, accepting the prevailing conditions as 'normal'.

The adjustment of seasonal preferences can be quite significant, even over a period of a month. Extensive studies showed that the 'neutrality temperature' (the median of many peoples' votes) changes with the mean temperature of the month, as

$$T_n = 17.6 + 0.31 \times T_{o.av} \tag{1.7}$$

where  $T_{o.av}$  is the mean temperature of the month (these coefficients are based on the work of Auliciems; several other research workers found correlation coefficients only slightly different).

Auliciems (1981) offered a psycho-physiological model of thermal perception, which is the basis of the adaptability model (Fig. 1.19)



**Fig. 1.19**  
The psycho-physiological model of thermal perception.

Humphreys (1978) examined a large number of comfort studies, correlated thermal neutrality with the prevailing climate, and for free-running buildings suggested the equation

$$T_n = 11.9 + 0.534 T_{o.av}$$

(where  $T_{o.av}$  is the month's mean outdoor temperature), thus laid the foundation of the adaptability model.

Auliciems (1981) reviewed the above data, supplemented it by others and proposed Eq. (1.7). Since then many other workers found similar correlations:

Griffiths (1990):

$$T_n = 12.1 + 0.534 T_{o.av}$$

Nicol & Roaf (1996):

$$T_n = 17 + 0.38 T_{o.av}$$

A very large study by De Dear et al (1997) produced correlations with outdoor  $ET^*$  (effective temperature) but later revised this and suggested

$$T_n = 17.8 + 0.31 T_{o.av}$$

which is practically the same as the Auliciems expression (Eq. 1.7), here adopted.

### 1.2.4 Comfort indices, comfort zone

Yagloglou (1923) devised the ET (effective temperature) scale to recognise the effect of humidity on thermal sensation. ET coincides with DBT at the saturation curve of the psychrometric chart and 'equal comfort lines' are shown sloping down to the right. This and the derived nomogram have been widely used, not only in the US (e.g. by most ASHRAE publications) but also in the UK (e.g. Vernon and Warner 1932, Bedford 1936, Givoni 1969, Koenigsberger et al. 1973)

Gagge et al. (1974), in the light of more recent research, created the 'New effective temperature' scale, denoted ET\* (ET star). This coincides with DBT at the 50% RH curve. Up to 14°C humidity has no effect on thermal comfort (ET\* = DBT) but beyond that the ET\* lines have an increasing slope. The slopes were analytically derived, differing for various combinations of activity and clothing. Recognising this difficulty Gagge et al. (1986) devised the SET (standard effective temperature scale), which is here adopted.

The range of acceptable comfort conditions is generally referred to as the comfort zone. The temperature limits of such a comfort zone (for 90% acceptability) can be taken relative to the above  $T_n$  (neutrality temperature) as from  $(T_n - 2.5)^\circ\text{C}$  to  $(T_n + 2.5)^\circ\text{C}$ .

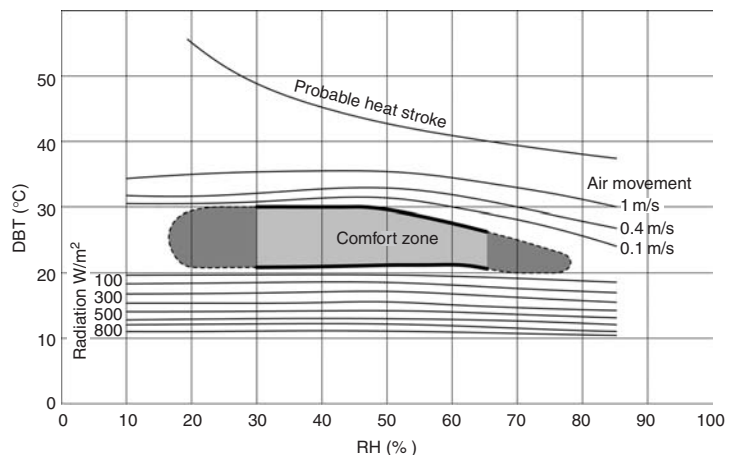
As thermal comfort is influenced by another three environmental variables, attempts have been made since the early 1900s to create a single figure comfort index, which would express the combined effect of all four (or at least several) of these variables. The first one was proposed by Houghten and Yagloglou in 1923, named 'effective temperature'. At least 30 different such indices have been produced over the years by various research workers, all based on different studies, all with different derivations and names.

Olgay (1953) introduced the 'bioclimatic chart' (Fig. 1.20) which has the DBT on the horizontal and the RH on the vertical axis, and the aerofoil shape in the middle is the 'comfort zone'. Curves above show how air movement can extend the upper limits and lines below it show the extension by radiation.

The latest comfort index now generally accepted, is the ET\* (ET star) or new effective temperature, and its standardised version, the SET. The ET\* constructed for 0.57 clo and 1.25 met has been found to be valid for the following conditions (as an increase in met could be compensated for by a decrease in clo):

met	clo
1	0.67
1.25	0.57
2	0.39
3	0.26
4	0.19

so this is now referred to as SET (Standard Effective Temperature).



**Fig. 1.20**

Olgay's bioclimatic chart, converted to metric, modified for warm climates.

The SET isotherms are drawn on the psychrometric chart (Fig. 1.14). The SET coincides with DBT at the 50% RH curve. The slope of the SET lines indicates that at higher humidities the temperature tolerance is reduced, whilst at lower humidities higher temperatures are acceptable. Up to 14°C the SET lines coincide with the DBT. Above that the slope of these isotherm lines is progressively increasing, with the slope coefficient taken as X/Y or DBT/AH = 0.023 × (T-14) which gives the deviation from the corresponding vertical DBT line for each g/kg AH, positive below the 50% RH curve and negative above it.

The SET thus defined combines the effect of temperature and humidity, the two most important determinants. The comfort zone can be plotted on this chart that will vary with the climate and be different for each month. The procedure may be as stated next.

Find the thermal neutrality (as Eq. 1.7:  $T_n = 17.6 + 0.31 \times T_{o.av}$ ) for both the warmest and the coldest month and take the comfort limits as  $T_n \pm 2.5^\circ\text{C}$ . Mark these on the 50% RH curve. These will define the 'side' boundaries of the comfort zone as the corresponding SET lines. The humidity limits (top and bottom) will be 12 and 4 g/kg respectively (1.9 and 0.6 kPa vapour pressure). Fig. 1.21 shows the comfort zones for Darwin and Budapest (note that the former has hardly any seasonal variation (a warm humid climate), whilst the latter (a cool temperate climate) shows a big difference between winter and summer comfort (see also method sheet M.1.7).

### 1.3 Climate

*Weather* is the set of atmospheric conditions prevailing at a given place and time. *Climate* can be defined as the integration in time of weather conditions, characteristic of a certain geographical location.‡

#### 1.3.1 The sun

The climate of earth is driven by the energy input from the sun. For designers there are two essential aspects to understand: the apparent movement of the sun (the solar geometry) and the energy flows from the sun and how to handle it (exclude it or make use of it).

The earth moves around the sun on a slightly elliptical orbit. At its maximum (aphelion) the earth-sun distance is 152 million km and at its minimum (perihelion) 147 million km. The earth's

‡ although Michael Glantz (of the US Center for Atmospheric Research) suggested that 'climate is what you expect and weather is what you get'.

E.g. for Budapest  
warmest month: July, mean temperature 23.1 °C

$$T_n = 17.6 + 0.31 \times 23.1 = 24.8^\circ\text{C}$$

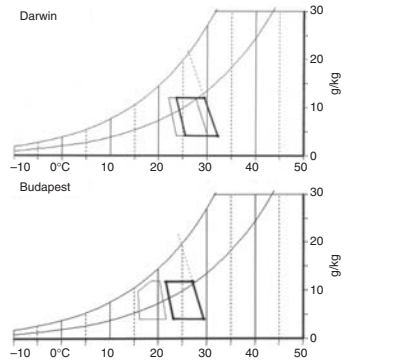
thus lower and upper limits  $T_L = 22.3^\circ\text{C}$  and  $T_U = 27.3^\circ\text{C}$  mark these on the 50% RH curve

For the side boundaries either follow the slope of SET lines or note the AH for these two points: 8.5 and 11.5 g/kg  
Then the base line intercepts will be

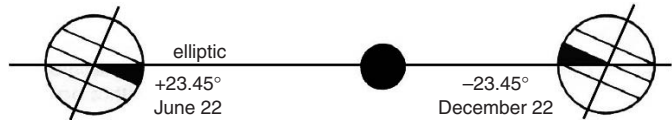
$$\text{for } T_L = 22.3 + 0.023 \times (22.3 - 14) \times 8.5 \cong 24^\circ\text{C}$$

$$\text{for } T_U = 27.3 + 0.023 \times (27.3 - 14) \times 11.5 \cong 31^\circ\text{C}$$

Draw the side boundaries.  
Top and bottom boundaries are at the 12 and 4 g/kg level



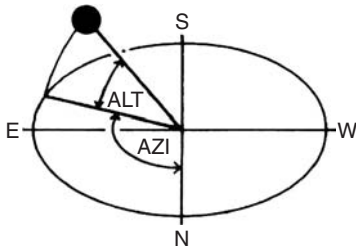
**Fig. 1.21**  
Winter and summer comfort zones for Darwin and Budapest. Heavy outline: summer; light outline trapezoid: winter.



**Fig. 1.22**  
2-D section of the earth's orbit.

axis is not normal to the plane of its orbit, but tilted by  $23.5^\circ$ . Consequently, the angle between the earth's equatorial plane and the earth-sun line varies during the year (Fig. 1.22). This angle is known as the declination (DEC) and varies as follows:

- + $23.45^\circ$  on June 22 (Northern solstice)
- 0 on March 21 and Sept. 22 (Equinox dates)
- $23.45^\circ$  on December 22 (Southern solstice)



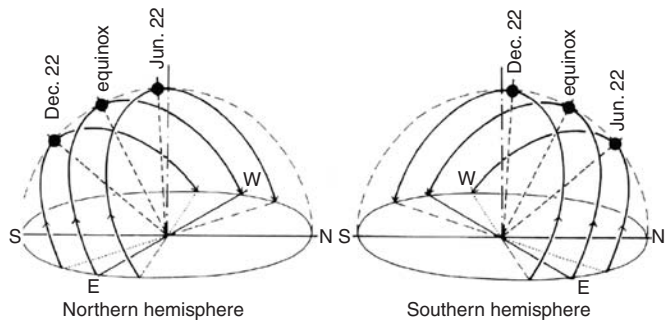
**Fig. 1.23**  
Altitude and azimuth angles.

Whilst the above heliocentric view is necessary for understanding the real system, in building problems the *lococentric* view provides all the necessary answers. In this view the observer's position is at the centre of the sky hemisphere, on which the sun's position can be determined by two angles (Fig. 1.23):

- altitude (ALT): measured upwards from the horizon,  $90^\circ$  being the zenith
- azimuth (AZI): measured in the horizontal plane from north ( $0^\circ$ ), through east ( $90^\circ$ ), south ( $180^\circ$ ) and west ( $270^\circ$ ) to north ( $360^\circ$ ).

These angles can be calculated for any time of the year by the trigonometrical equations given in method sheet M.1.3. Conventionally  $\alpha$  is used for ALT and  $\gamma$  is used for AZI, but here 3-letter abbreviations are adopted for all solar angles to avoid confusion with other uses of the Greek letters.

The sun has the highest orbit and will appear to be on the zenith at noon on June 22 along the Tropic of Cancer ( $LAT=+23.45^\circ$ ) and along the Tropic of Capricorn ( $LAT = -23.45^\circ$ ) on December 22. Fig. 1.24 shows the lococentric view of sun paths for a northern



**Fig. 1.24**  
Lococentric view of the sky hemisphere with sun-paths for the main dates.

and a southern hemisphere location (drawn for  $LAT = 28^\circ$  and  $-28^\circ$ ).

The sun rises at due east on equinox dates. In the northern hemisphere it travels through south in a clockwise direction but in the southern hemisphere it travels through the north in an anti-clockwise direction (for an observer facing the equator), to set at due west.

**1.3.1.1 Sun-path diagrams** or solar charts are the simplest practical tools for depicting the sun's apparent movement. The sky hemisphere is represented by a circle (the horizon). *Azimuth* angles (i.e. the direction of the sun) are given along the perimeter and *altitude* angles (from the horizon up) are shown by a series of concentric circles,  $90^\circ$  (the zenith) being the centre.

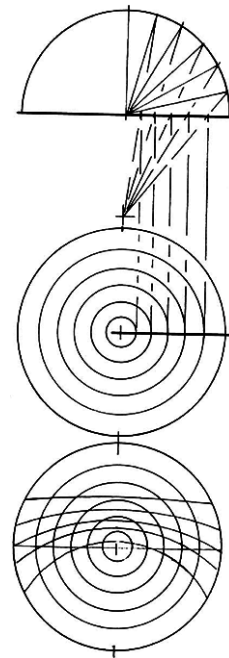
Several methods are in use for the construction of these charts. The orthographic, or parallel projection method is the simplest, but it gives very compressed altitude circles near the horizon. The equidistant method is in general use in the US, but this is not a true geometrical projection. The most widely used are the stereographic charts. These are constructed by a radial projection method (Fig. 1.25), in which the centre of projection is vertically below the observer's point, at a distance equal to the radius of the horizon circle (the nadir point). For the construction of stereographic sun-path diagrams and shadow angle protractor see method sheet M.1.4.

The sun-path lines are plotted on this chart for a given latitude for the solstice days, for the equinoxes and for any intermediate dates as described in method sheet M.1.4. For an equatorial location ( $LAT = 0^\circ$ ) the diagram will be symmetrical about the equinox sun-path, which is a straight line; for higher latitudes the sun-path lines will shift away from the equator. For a polar position the sun-paths will be concentric circles (or rather an up and down spiral) for half the year, the equinox path being the horizon circle, and for the other half of the year the sun will be below the horizon. The shifting of sun-paths with geographical latitudes is illustrated by Fig. 1.26.

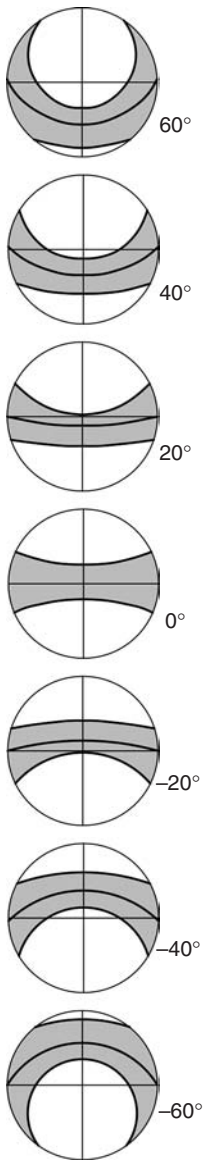
The date-lines (sun-path lines) are intersected by hour lines. The vertical line at the centre is noon. Note that on equinox dates the sun rises at due east at 06:00 and sets at due west at 18:00 h. As an example a complete sun-path diagram for latitude  $36^\circ$  is given as Fig. 1.27.

The time used on solar charts is solar time, which coincides with local clock time only at the reference longitude of each time zone. Every  $15^\circ$  longitude band gives one hour difference ( $360/24 = 15$ ), therefore every degree longitude means a time difference of  $60/15 = 4$  min.

E.g. for Brisbane, longitude  $153^\circ$  E the reference longitude is  $150^\circ$  ( $10$  h ahead of Greenwich); the  $3^\circ$  difference means that the local



**Fig. 1.25**  
Stereographic projection method.



**Fig. 1.26**  
The shift of sun-path lines on the solar chart, with latitudes.

clock time is  $3 \times 4 = 12$  min behind solar time (i.e. at solar noon the clock shows only 11:48 h).

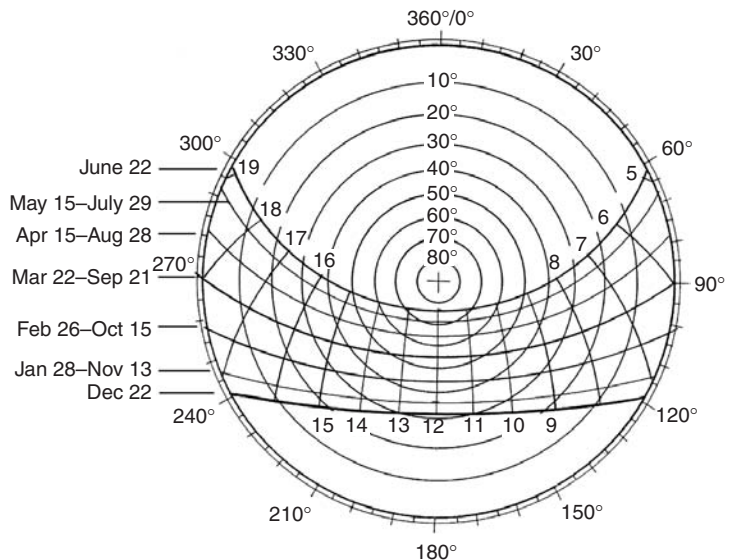
**1.3.1.2 Solar radiation.** Its quantity can be measured in two ways:

- (1) irradiance, in  $\text{W}/\text{m}^2$  (in older texts referred to as 'intensity'), i.e. the instantaneous flux- or energy flow density, or 'power density',
- (2) irradiation, in  $\text{J}/\text{m}^2$  or  $\text{Wh}/\text{m}^2$ , an energy quantity integrated over a specified period of time (hour, day, month or year). (see also Section 1.4.1.2)

The sun's surface is at a temperature of some  $6000^\circ\text{C}$ , thus the peak of its radiant emission spectrum is around the  $550\text{ nm}$  wavelength, extending from  $200$  to  $3000\text{ nm}$ . According to human means of perception we can distinguish:

- (a) ultraviolet radiation,  $200\text{--}380\text{ nm}$ , which produces photochemical effects, bleaching, sunburn, etc.
- (b) light, or visible radiation, from  $380$  (violet) to  $700\text{ nm}$  (red),
- (c) short infrared radiation,  $700\text{--}3000\text{ nm}$ , or thermal radiation, with some photochemical effects.

If a graph of continuously changing solar radiation is drawn against time (Fig. 1.28), the ordinate represents irradiance and the area under the curve is irradiation (the 10 am irradiance,  $\text{W}/\text{m}^2$ , is numerically the same as irradiation for the hour 9:30–10:30, in  $\text{Wh}/\text{m}^2$ ).



**Fig. 1.27**  
A stereographic sun-path diagram for latitude  $36^\circ$ .



At the outer limits of the earth’s atmosphere the annual mean value of irradiance is  $1353 \text{ W/m}^2$ , measured at normal incidence, i.e. on a plane perpendicular to the direction of radiation. This is referred to as the ‘solar constant’, but it varies  $\pm 2\%$  due to variations in the sun’s emission itself and  $\pm 3.5\%$  due to the changing earth–sun distance.

As the earth’s radius is  $6376 \text{ km}$  ( $6.376 \times 10^6 \text{ m}$ ), its circular projected area is  $(6.376 \times 10^6)^2 \times 3.14 \approx 127 \times 10^{12} \text{ m}^2$ , it continuously receives a radiant energy input of  $1.353 \times 127 \times 10^{12} \approx 170 \times 10^{12} \text{ kW}$ . Some 25% of this is reflected without change in quality, another 25% is absorbed in the atmosphere and is re-radiated as long-wave infrared radiation. The remaining 50% reaches the earth’s surface and enters the terrestrial system. Ultimately all of it is re-radiated, this being a condition of equilibrium (see Fig. 1.32).

There are large variations in irradiation amongst different locations on the earth, for three reasons:

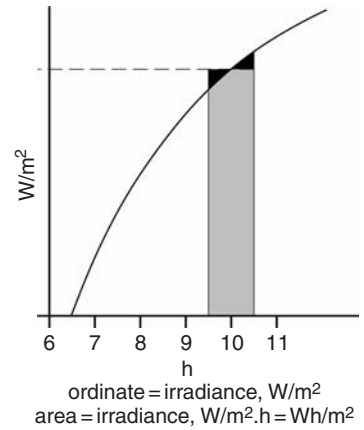
- (a) angle of incidence: according to the cosine law (Fig. 1.29) the irradiance received by a surface is the normal irradiance times the cosine of the angle of incidence (INC);
- (b) atmospheric depletion, a factor varying between 0.2 and 0.7, mainly because at lower altitude angles the radiation has to travel along a much longer path through the atmosphere, (especially through the lower, denser and most polluted layer), but also because of variations in cloud cover and atmospheric pollution (Fig. 1.30);
- (c) duration of sunshine, i.e. the length of daylight period (sunrise to sunset) and to a lesser extent also on local topography.

The maximum irradiance at the earth’s surface is around  $1000 \text{ W/m}^2$  and the annual total horizontal irradiation varies from about  $400 \text{ kWh/m}^2\text{y}$  near the poles to a value in excess of  $2500 \text{ kWh/m}^2\text{y}$  in the Sahara desert or northwestern inland Australia.

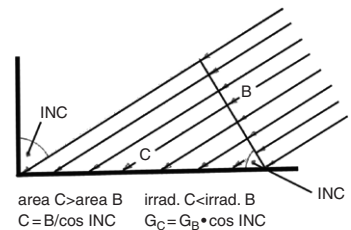
### 1.3.2 Global climate, greenhouse effect

At the global level climates are formed by the differential solar heat input and the almost uniform heat emission over the earth’s surface. Equatorial regions receive a much greater energy input than areas nearer to the poles. This differential is the main driving force of atmospheric phenomena (winds, cloud formations and movements), which provide a heat transfer mechanism from the equator towards the poles.

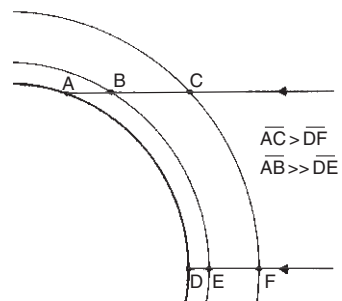
In the absence of such heat transfer the mean temperature at the north pole would be  $-40$ , rather than the present  $-17^\circ\text{C}$  and at the equator it would be about  $33$  and not  $27^\circ\text{C}$  as at present.



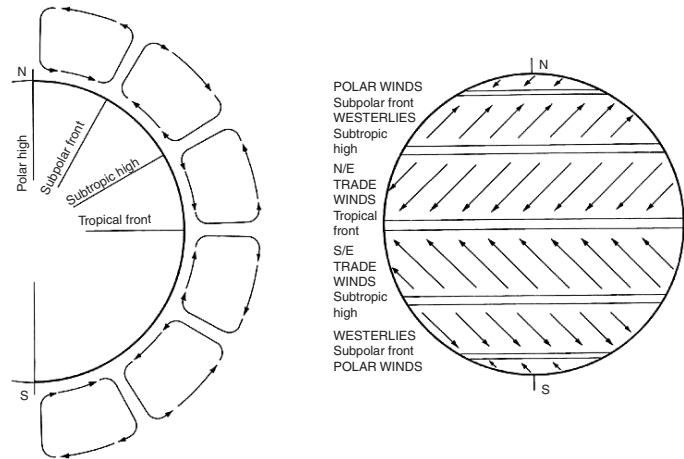
**Fig. 1.28**  
Irradiance and irradiation.



**Fig. 1.29**  
Angle of incidence.



**Fig. 1.30**  
Radiation path lengths through the atmosphere.



**Fig. 1.31**  
The global wind pattern.

At points of strong heating the air rises and at a (relatively) cold location it sinks. The movement of air masses and of moisture-bearing clouds is driven by temperature differentials, but strongly influenced by the *Coriolis force*, explained below (Fig. 1.31):

A 'stationary' air mass at the equator in fact moves with the earth's rotation and it has a certain circumferential velocity (some 1600 km/h or 463 m/s), hence it has a moment of inertia. As it moves towards the poles (at high level), the circumference of the earth (the latitude circle) is reducing, therefore it will overtake the surface. An air mass at a higher latitude has a lesser velocity and inertia, and when moving towards the equator (a larger circumference), it will lag behind the earth's rotation. This mechanism causes the N/E and SE trade winds.

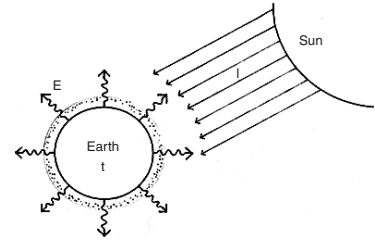
The atmosphere is a very unstable three-dimensional system, thus small differences in local heating (which may be due to topography and ground cover) can have significant effects on air movements and influence the swirling patterns of low and high pressure (cyclonic and anti-cyclonic) zones.

Earth, which has an average radius of 6376 km, is surrounded by a very thin atmosphere. Its depth is usually taken as 80 km, which is the top of the mesosphere, where the pressure drops to practically zero, although some trace gases can still be found up to about 160 km. If the earth were to be represented by a sphere of the size of a soccer football, the thickness of its atmosphere would be only about 1.5 mm. The first 9 km thick layer contains about half of the total mass of the atmosphere and an 18 km layer houses practically all life. All our climatic phenomena take place within this thin layer. To continue the football analogy, this would correspond to a layer of 0.3 mm thickness. Indeed, it is a very delicate, highly vulnerable and fragile mantle (Szokolay, 1992).



The **greenhouse effect** is caused by the following mechanism. The solar radiation input ( $I$  in Fig. 1.32) into the terrestrial system is at the rate of some  $170 \times 10^{12}$  kW (as shown in Section 1.3.1.2). Equilibrium is maintained with an equal rate of energy emission ( $E$ ) to space.  $E$  is determined by the earth's surface temperature ( $t$ ) and the optical transparency (the retardation effect) of the atmosphere. The optical transparency of the atmosphere is quite high for short-wave solar radiation, but much less so for long-wave infrared, emitted by the earth's surface.

If this is further reduced by an increased  $\text{CO}_2$  content (or other greenhouse gases), the  $t$  will increase until  $E$  is restored to gain a new equilibrium. This is referred to as the *greenhouse effect*, and it is the cause of *global warming*.



**Fig. 1.32**  
The Earth's heat balance: causes of the greenhouse effect.

### 1.3.3 Elements of climates: data

The main climatic elements regularly measured by meteorological organisations and published in summary form are:

1. Temperature (DBT), measured in the shade, usually in a ventilated box, the Stevenson screen, 1.2–1.8 m above ground level.
2. Humidity, which can be expressed as RH or AH, or the WBT or dew-point temperature (DPT) can be stated.
3. Air movement, i.e. wind, normally measured at 10 m above ground in open country, but higher in built-up areas, to avoid obstructions; both velocity and direction are recorded.
4. Precipitation, i.e. the total amount of rain, hail, snow or dew, measured in rain gauges and expressed in mm per unit time (day, month, year).
5. Cloud cover, based on visual observation, expressed as a fraction of the sky hemisphere (tenths or 'octas' = eighths) covered by clouds.
6. Sunshine duration, i.e. the period of clear sunshine (when a sharp shadow is cast), measured by a sunshine recorder, in which a lens burns a trace on a paper strip; shown as hours per day or month.
7. Solar radiation, measured by a pyranometer (solarimeter), on an unobstructed horizontal surface and recorded either as the continuously varying irradiance ( $\text{W}/\text{m}^2$ ), or through an electronic integrator as irradiation over the hour or day. If the hourly value of irradiation is given in  $\text{Wh}/\text{m}^2$ , it will be numerically the same as the average irradiance ( $\text{W}/\text{m}^2$ ) for that hour (Fig. 1.28).

As the four environmental variables directly affecting thermal comfort are temperature, humidity, radiation and air movement, these are the four constituents of climate most important for the purposes of building design.

The problem in the presentation of climatic data is to strike a balance between the two extremes of

- too much detail: e.g. hourly temperatures for a year,  $24 \times 365 = 8760$  items; it would be very difficult to glean any meaning from such a mass of numbers and, if many years are to be considered, it would be an impossible task;
- oversimplification: e.g. the statement of the annual mean temperature of (say)  $15^{\circ}\text{C}$ , which may indicate a range between  $10$  and  $20^{\circ}\text{C}$  or between  $-10$  and  $+40^{\circ}\text{C}$ . The greater the simplification, the more detail is concealed.

For all but the most detailed thermal performance analysis the following data are adequate, as a minimum requirement:

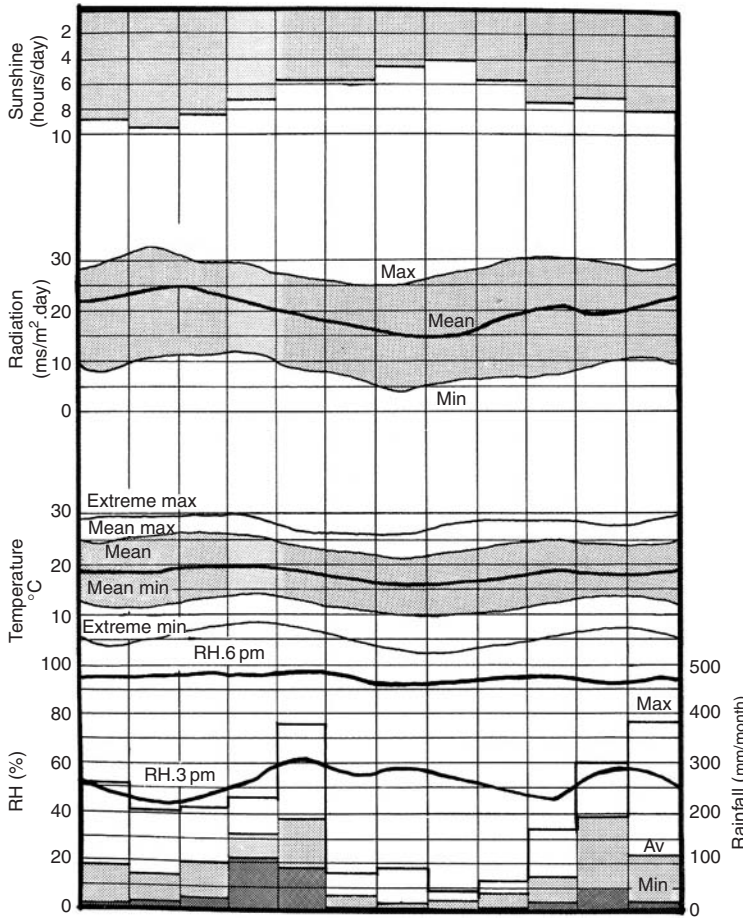
Temperature:	monthly means of daily maxima ( $^{\circ}\text{C}$ )
	standard deviation of its distribution (K)
	monthly means of daily minima ( $^{\circ}\text{C}$ )
	standard deviation of its distribution (K)
Humidity:	early morning relative humidity (%)
	early afternoon relative humidity (%)
Rainfall:	monthly totals (mm)
Irradiation:	monthly mean daily total ( $\text{Wh}/\text{m}^2$ )

Such data may be presented in tabular form, for example in Fig. 1.33, or in graphic form, as a composite climate graph (Fig. 1.34) which assists understanding at a glimpse and, in a simplified form, allows a quick comparison, as in Fig. 1.39.

Much more detailed data may be required for the purposes of some thermal response simulation programs, such as hourly data for a year, which itself may be a composite construct from many years of actual data. Such data are available for some locations in digital format, referred to as 'weather-tapes or files'. Much effort

Climatic data for NAIROBI											Latitude: $-1.2^{\circ}$		
	Jan	Feb	Mar	Apr	May	Jun	Jul	Aug	Sep	Oct	Nov	Dec	
T.max	25.0	26.0	26.0	24.0	23.0	22.0	21.0	22.0	24.0	25.0	23.0	23.0	$^{\circ}\text{C}$
SD.max	1.7	1.7	1.5	1.1	1.7	1.6	1.5	1.5	1.5	1.1	1.1	1.2	K
T.min	11.0	11.0	13.0	14.0	13.0	11.0	9.0	10.0	10.0	12.0	13.0	13.0	$^{\circ}\text{C}$
SD.min	2.0	1.7	1.2	1.2	2.2	2.5	2.5	2.0	1.6	1.2	1.7	2.0	K
RH.am	95	94	96	95	97	95	92	93	95	95	93	95	%
RH.pm	48	42	45	55	61	55	57	53	48	45	56	55	%
Rain	88	70	96	155	189	29	17	20	34	64	189	115	mm
Irrad	6490	6919	6513	5652	4826	4664	3838	4047	5245	5629	5489	6024	$\text{Wh}/\text{m}^2$
(standard deviations are estimated only)													

**Fig. 1.33**  
The simplest climatic data.

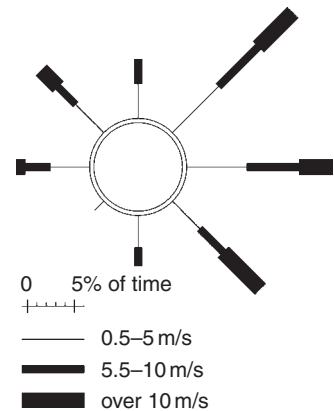


**Fig. 1.34**  
A composite climate graph (Nairobi).

has been spent on producing a year of hourly climatic data, variously referred to as TRY (test reference year), or TMY (typical meteorological year) or WYEC (weather year for energy calculations). These are required and used by various computer programs to simulate the thermal performance of buildings and consequent energy use.

There are many levels of simplification, such as using 3-hourly data or representing each month by a typical sequence of three days of hourly data. For the purposes of all calculations in this book the above described monthly mean data are adequate.

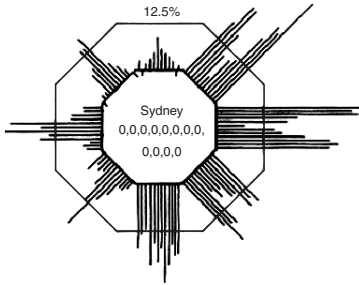
**1.3.3.1 Wind data** are best presented graphically. Several different types of wind roses can be used for this purpose. One method presents a separate wind rose (Fig. 1.35) for each month (or sometimes one wind rose representing three months, i.e. four wind roses



**Fig. 1.35**  
A wind rose for one month.

representing the four seasons of the year). The length of lines radiating from a small circle is proportionate to the frequency of wind from that direction. Different line thicknesses may indicate wind velocity categories.

For architectural purposes the most useful form of wind rose is an octagon, with 12 lines on each side, corresponding to the 12 months, from January to December in a clockwise direction, where the length of a line is proportionate to the frequency (% of observations) of wind from that direction in that month. If the winds were evenly distributed, all lines would extend to the outer octagon, which indicates a line length of 12.5%. Small dashes on the inside of the base octagon indicate that there is no wind in that month from that direction (Fig. 1.36). The 12 numbers inside the graph give the % of total calm periods for the 12 months. It is usual to give a wind rose for an early morning and one for a mid-afternoon hour. Often, two such graphs are shown, one for 9 am and one for 3 pm.



**Fig. 1.36**  
An annual wind rose.

These may be supplemented by a tabulated wind frequency analysis, such as that shown in Fig. 1.37 for one month.

**1.3.3.2 Derived data** such as *Degree-days* (DD or Kd, Kelvin-days) or heating degree-days (HDD) is a climatic concept that can be defined as 'the cumulative temperature deficit below a set base temperature ( $T_b$ )'. In other words: the temperature deficit times

9 am January									
calm 25									
1859 observations									
km/h	N	NE	E	SE	S	SW	W	NW	all
1–10	1	1	1	9	22	3	1	1	39
11–20	1	—	—	5	21	2	—	1	30
21–30	—	—	—	1	4	—	—	—	6
>30	—	—	—	—	—	—	—	—	1
all	2	1	1	15	47	5	1	2	100
3 pm January									
calm 5									
1854 observations									
km/h	N	NE	E	SE	S	SW	W	NW	all
1–10	6	5	3	2	2	2	—	1	20
11–20	12	14	9	8	4	—	—	1	50
21–30	2	3	5	10	3	—	—	—	23
>30	—	—	—	2	—	—	—	—	3
all	20	22	17	22	10	1	1	2	100

—

 less than 1%
  no wind from that direction

**Fig. 1.37**  
Wind frequency analysis.

its duration, summed up for the year. It can be obtained if from January 1 we go through the year day by day and whenever the mean temperature of the day ( $T_{av}$ ) is less than this  $T_b$ , we write down the difference and add these up (negative differences are ignored). Thus for the year, if  $T_b = 18^\circ\text{C}$

$$DD = Kd = \sum (18 - T_{av}) \quad (\text{from day 1 to 365})$$

or generally

$$DD = Kd = \sum (T_b - T_{av}) \quad (1.8)$$

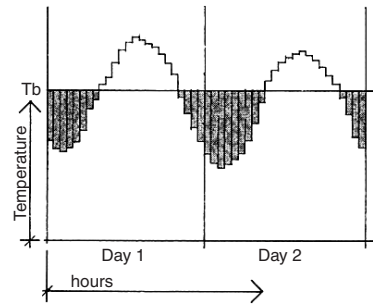
Such sums can be produced separately for each month.

*Degree-hours* can be estimated as  $Dh = Kh = Kd \times 24$ , but more accurately a summation similar to the above can be carried out on an hourly basis. If  $T_h =$  hourly temperature:

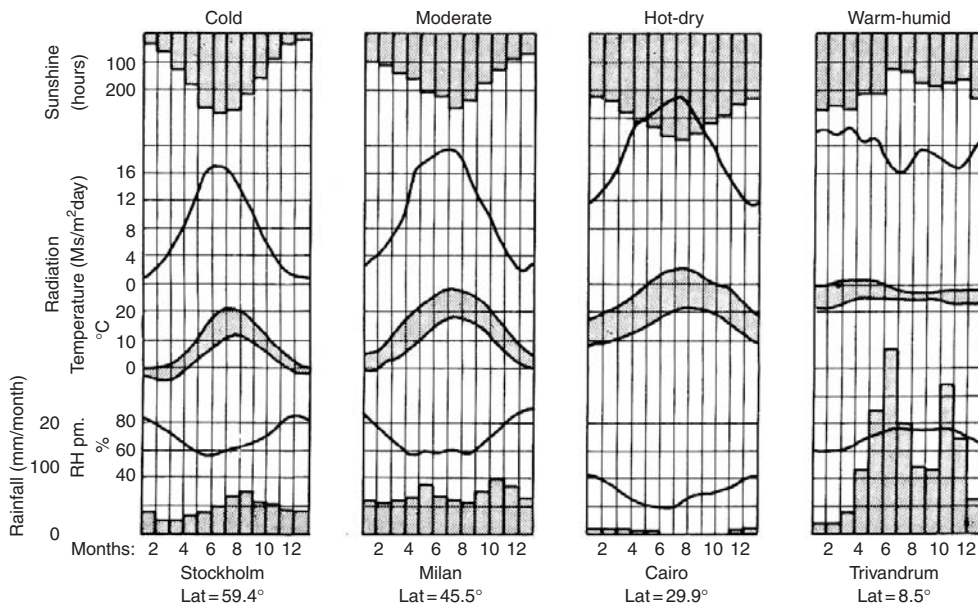
$$Kh = \sum (18 - T_h) \quad (\text{from hour 1 to 8760})$$

or indeed, separately for each month.

This can also be visualised from a continuous temperature graph (Fig. 1.38) as the area under the curve measured below the  $T_b$  level, where the ordinate is in K (degrees temperature difference) and the abscissa in h (hours), therefore the area is  $Kh$ , Kelvin-hours or degree-hours.



**Fig. 1.38**  
Definition of degree-hours ( $Kh$ ).



**Fig. 1.39**  
Composite (simplified) climate graphs for the four basic types.

(Kd and Kh are the preferred terms, to avoid confusion with American DD data given in terms of °F.)

Method sheet M.1.5 shows the calculation of degree-days and converting this to degree-hours from monthly mean data, to any base temperature, which can be used if the standard deviation of the temperature distribution is known.

The concept is useful for estimating the annual (or monthly) heating requirement. Kelvin-hours is the climatic parameter used and the building parameter is the building conductance (specific heat loss rate) (q). The heating requirement (Htg) is the product of the two:

$$\text{Htg} = K_h \times q \quad (K_h \times W/K = \text{Wh}) \quad (1.9)$$

Sometimes the 'cooling degree-days' (or degree-hours) concept is used for the estimation of cooling requirements. This is conceptually similar to the above, but the base temperature is usually taken as 26°C and the temperatures in excess of this base are considered

$$\text{CDD} = \sum (T_{\text{av}} - 26) \quad (\text{from day 1 to 365})$$

This is nowhere near as reliable as the heating requirement calculation, as cooling requirements depend also on solar heat gain (which is different for each building surface and also depends on fenestration), internal heat gain and on atmospheric humidity (the determinant of latent heat load). There are methods of making some allowance for these, (making assumptions of 'average conditions') but these have no general validity.

### 1.3.4 Classification of climates

Many different (and some very complex) systems of climate classification are in use, for different purposes. Some are based on vegetation, others on evapo-transpiration. The most generally used system is the Köppen–Geiger classification, which distinguishes some 25 climate types.

For the purposes of building design a simple system (after Atkinson, 1954), distinguishing only four basic types, is adequate. This is based on the nature of the human thermal problem in the particular location.

- 1 *Cold* climates, where the main problem is the lack of heat (underheating), or excessive heat dissipation for all or most of the year.
- 2 *Temperate* (moderate) climates, where there is a seasonal variation between underheating and overheating, but neither is very severe.

- 3 *Hot-dry* climates, where the main problem is overheating, but the air is dry, so the evaporative cooling mechanism of the body is not restricted. There is usually a large diurnal (day–night) temperature variation.
- 4 *Warm-humid* climates, where the overheating is not as great as in hot-dry areas, but is aggravated by high humidities, restricting the evaporation potential. The diurnal temperature variation is small.

Sometimes we consider also the following sub-types:

- 1(a) island or trade-wind climate,
- 2(b) maritime desert climate,
- 3(a) tropical highland climate.

or indeed ‘composite climates’, with seasonally changing characteristics.

## 1.4 Thermal behaviour of buildings

A building can be considered as a thermal system, with a series of heat inputs and outputs (analogous to Eq. (1.6) for the human body):

- $Q_i$  – internal heat gain
- $Q_c$  – conduction heat gain or loss
- $Q_s$  – solar heat gain
- $Q_v$  – ventilation heat gain or loss
- $Q_e$  – evaporative heat loss.

The system can be depicted by the following equation:

$$Q_i + Q_c + Q_s + Q_v + Q_e = \Delta S \quad (1.10)$$

where  $\Delta S$  is a change in heat stored in the building.

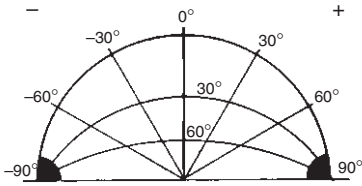
Thermal balance exists when the sum of all heat flow terms, thus  $\Delta S$  is zero. If the sum is greater than zero, the temperature inside the building is increasing, or if it is less than zero, the building is cooling down.

The system can be analysed assuming *steady-state* conditions, i.e. both the indoor and the outdoor conditions are taken as steady, non-changing, or we can consider the building’s dynamic response. The former may be valid when the diurnal changes are small compared with the indoor–outdoor temperature difference, or as the basis of finding the required heating or cooling capacity, under assumed ‘design’ conditions, or – indeed – as a first approach to fabric design.

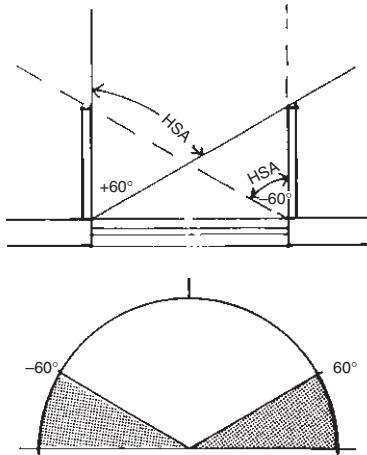
The most significant energy input into a building is solar radiation. The next section examines the solar heat input and its control. This will be followed by the other components of Eq. (1.10).

### 1.4.1 Solar control

The first task in solar control is to determine *when* solar radiation would be a welcome input (solar heating for the underheated period) or when it should be excluded (the overheated period). This overheated period can then be outlined on the sun-path diagram (as shown in method sheet M.1.9). The performance of a shading device is depicted by a *shading mask*, which can be constructed with the aid of the shadow angle protractor (Fig. 1.40). This is then superimposed on the diagram, corresponding to the window's orientation. A device is to be found, the shading mask of which covers the overheated period.



**Fig. 1.40**  
The shadow angle protractor.



**Fig. 1.41**  
Plan of a pair of vertical devices (fins) and their shading mask.

**1.4.1.1 Shading design** for the exclusion of solar input is a geometrical task. External shading devices are the most effective tools to control sun penetration. Three basic categories of shading design devices can be distinguished:

- (a) **Vertical devices**, e.g. vertical louvres or projecting fins. These are characterised by *horizontal shadow angles* (HSA) and their shading mask will be of a sectoral shape (Fig. 1.41). By convention HSA is measured from the direction of orientation (i.e. from the surface normal), positive in clockwise and negative in the anticlockwise direction. The HSA cannot be greater than  $90^\circ$  or less than  $-90^\circ$ , as that would indicate that the sun is behind the building. These devices may be symmetrical, with identical performance from left and right, or asymmetrical. They are most effective when the sun is towards one side of the direction the window is facing. We may distinguish the 'device HSA' (as above) and the 'solar HSA', which is the required performance at a given time.
- (b) **Horizontal devices**, e.g. projecting eaves, a horizontal canopy or awning, or horizontal louvres and slats. These are characterised by a *vertical shadow angle* (VSA). One large or several small elements may give the same performance, the same vertical shadow angle. Their shading mask, constructed by using the shadow angle protractor (see method sheet M.1.4), will be of a segmental shape. They are most effective when the sun is near-opposite to the window considered. Fig. 1.42 shows a canopy with a 'device VSA' of  $60^\circ$ .

The 'solar VSA' is the same as the ALT (altitude) only when the sun is directly opposite the window (when  $AZI = ORI$ , or solar  $HSA = 0$ ). When the sun is to one side of the surface



normal, its altitude must be projected onto a vertical plane perpendicular to the window (Fig. 1.43). For the calculation of these angles see method sheet M.1.3.

- (c) *Egg-crate devices*, e.g. concrete grille-blocks, metal grilles. These produce complex shading masks, combinations of the above two and cannot be characterised by a single angle. An example of this is shown in Fig. 1.44.

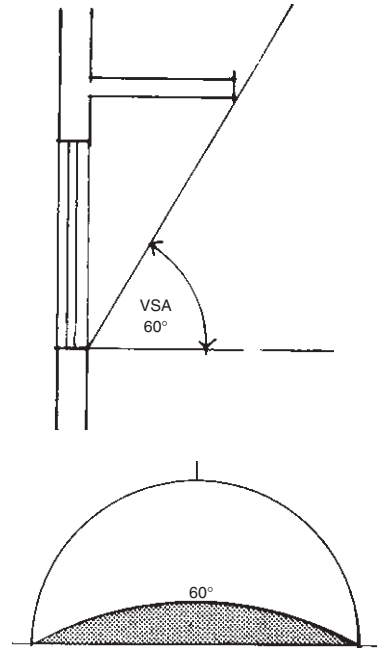
A window facing the equator (south in the northern hemisphere and due north in the southern hemisphere) is the easiest to handle. It can give an automatic seasonal adjustment: full shading in summer but allowing solar heat gain in winter (Fig. 1.45). For complete summer six-months sun-exclusion (for an equinox cut-off) the vertical shadow angle will have to be  $VSA = 90^\circ - LAT$ ; e.g. for  $LAT = 36^\circ$  it will be  $VSA = 90 - 36 = 54^\circ$ .

This shading mask exactly matches the equinox sun-path line. For other dates the match is not so exact, but still quite similar to the sun-path line. For orientations other than due north the situation is not so simple. A combination of vertical and horizontal devices may be the most appropriate answer.

The suggested procedure is the following (refer to Fig. 1.46):

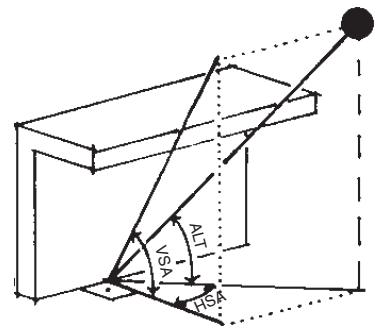
1. Draw a line across the centre of the sun-path diagram, representing the plan of the wall face considered (i.e. the surface normal being the orientation). During any period when the sun is behind this line, its radiation would not reach that wall, thus it is of no interest. The illustration shows a north-east orientation ( $LAT = -36^\circ, ORI = 45^\circ$ ).
2. Mark on the sun-path diagram the period when shading is desirable. In the illustration this is taken as the summer 6 months, i.e. its boundary is the equinox sun-path line (heavy outline).
3. Select a shading mask, or a combination of shading masks which would cover this shading period, with the closest possible match.
4. Several combinations of vertical and horizontal shadow angles may give satisfactory results:
  - a combination of  $VSA = 30^\circ$  and  $HSA = +20^\circ$  would give the required shading, but would also exclude the winter sun from about 10:00 h, which is undesirable.
  - a combination of  $VSA = 47^\circ$  and  $HSA = +0^\circ$  would also provide complete shading for 6 months, but still exclude the mid-winter sun after 12:00 h (noon).
  - a combination of  $VSA = 60^\circ$  and  $HSA = +20^\circ$  may be an acceptable compromise: on Feb. 28 the sun would enter from 09:20 to 11:00 h (a little longer in early March).

**1.4.1.2 Radiation calculations.** At any location and with respect to a surface of any orientation (ORI) and any tilt angle (TIL) the angle of incidence (INC) is continuously changing. For any



**Fig. 1.42**

A horizontal device (a canopy) and its shading mask.



**Fig. 1.43**

Relationship of ALT and VSA.

desired point in time it can be calculated by the expressions given in method sheet M.1.3.

The global irradiance ( $G$ ) incident on a particular surface consists of two main components:

- $G_b$  = beam or direct component, reaching the surface along a straight line from the sun (this is a vectorial quantity and depends on the angle of incidence);
- $G_d$  = diffuse component, i.e. the radiation scattered by the atmosphere, thus arriving at the surface from the whole of the sky hemisphere (depends on how much of the hemisphere is 'seen' by the surface);

possibly also

- $G_r$  = reflected component; if the surface is other than horizontal, it may be reached by radiation reflected from the ground or nearby surfaces;
- $G = G_b + G_d (+G_r)$ .

A second subscript is necessary to specify the surface on which the irradiance is considered:

- h = horizontal
- n = normal to the beam
- p = on a plane of given orientation (ORI) and tilt (TIL)
- v = vertical, of given orientation (ORI).

For details of such radiation calculations refer to method sheet M.1.6.

In the literature, the symbol  $H$  is often used for irradiation (e.g. hourly or daily total). Here the symbol  $D$  is adopted, to avoid confusion with enthalpy.

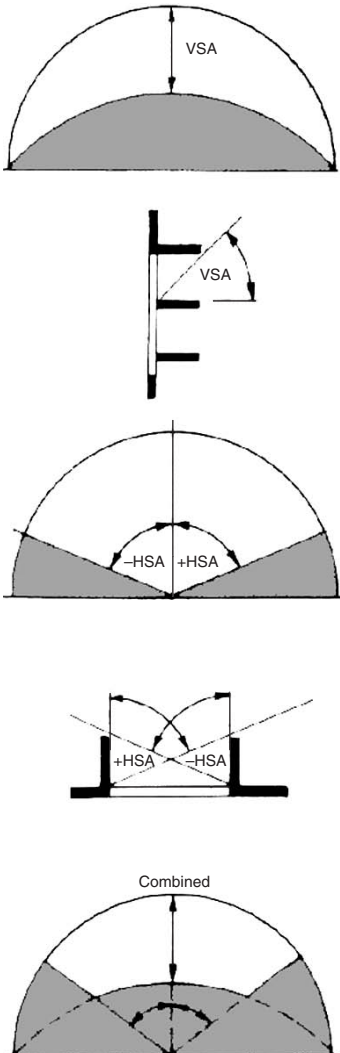
$D$  can have the same subscripts as  $G$  (except  $n$ ), i.e:

- b = beam component      h = on a horizontal plane
- d = diffuse component    p = on a given plane
- r = reflected component   v = vertical plane of given ORI

Very often the available data give only the horizontal total irradiation for an average day of each month. Before this could be transposed to other planes it must be split into beam and diffuse components, then the hourly values of both components must be estimated. This is a lengthy calculation, more suited to computer programs, but method sheet M.1.6 gives the appropriate algorithms.

**1.4.1.3 Solar heat gain** is considered differently for transparent and opaque surfaces. The global irradiance incident on the surface ( $G$ , in  $W/m^2$ ) must be known in both cases.

**Transparent elements** (windows): the solar gain is the product of this  $G$ , the area of the window and the solar gain factor ( $\theta$ ). This



**Fig. 1.44**  
An egg-crate device and its shading masks.

is a decimal fraction indicating what part of the incident radiation reaches the interior. (In the USA this is referred to as SHGC, solar heat gain coefficient.) Values for different glazing systems are given in data sheet D.1.6.

Some part of the incident radiation is transmitted ( $\tau$ ), some reflected ( $\rho$ ) and the remainder is absorbed ( $\alpha$ ) within the body of the glass.

$$\tau + \rho + \alpha = 1$$

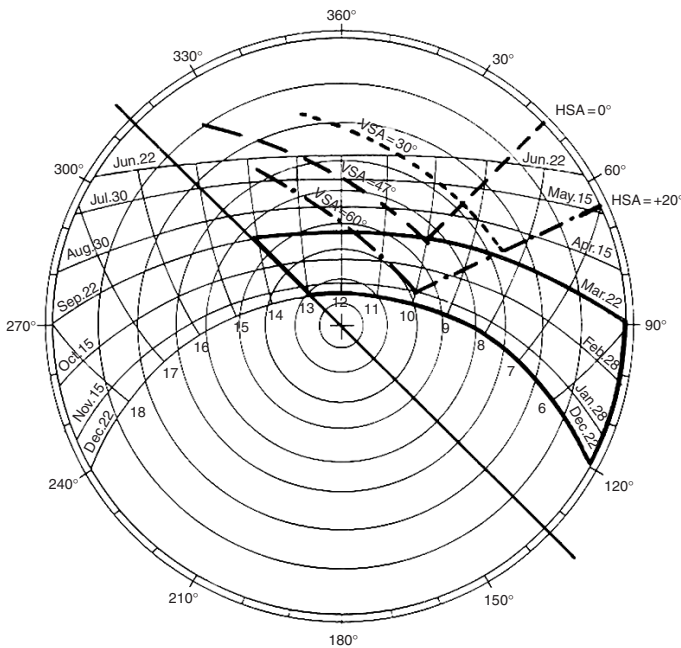
The absorbed part will heat up the glass, which will emit some of this heat to the outside, some of it to the inside, by re-radiation and convection (Fig. 1.47). The  $\theta$  is the sum of this inward re-emitted heat and the direct transmission. Therefore the solar gain through a window is:

$$Q_s = A \times G \times \theta. \tag{1.11}$$

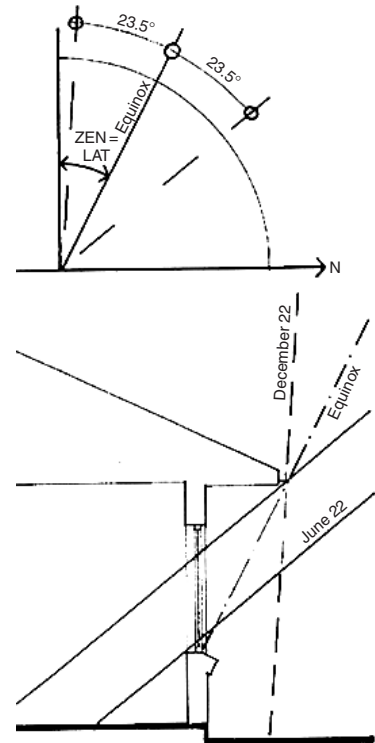
**Opaque elements:** the solar heat input is treated through the sol-air temperature concept. This can be explained as follows:

The radiant heat input into unit area of a surface depends on its absorptance ( $\alpha$ , see data sheet D.1.2)

$$Q_{in} = G \times \alpha. \tag{1.12}$$



**Fig. 1.46**  
Design procedure for composite shading.



**Fig. 1.45**  
Equinox cut-off for summer shading and winter sun-entry (southern hemisphere, north-facing window).

This heat input will elevate the surface temperature ( $T_s$ ), which will cause heat dissipation to the environment. The heat loss depends on the surface conductance ( $h$ )

$$Q_{loss} = h \times (T_s - T_o).$$

As the surface temperature increases, equilibrium will be reached when

$$Q_{in} = Q_{loss}$$

i.e.

$$G \times \alpha = h \times (T_s - T_o)$$

and then the temperature will stabilise (Fig. 1.48).

From this the  $T_s$  can be expressed as

$$\begin{aligned} T_s &= T_o + G \times \alpha / h \quad \text{or} \\ &= T_o + G \times \alpha \times R_{so} \quad (\text{as } 1/h = R_{so}). \end{aligned} \tag{1.13}$$

This derivation neglects any heat flow from the surface into the body of the element, thus  $T_s$  is not a true surface temperature; it is the notional *sol-air temperature*, ( $T_{s-a}$ ) which is the driving force of the heat flow.

For surfaces exposed to the sky (roofs) a radiant emission term should be included in the sol-air temperature expression:

$$T_{s-a} = T_o + (G \times \alpha - E) / h \quad \text{or} \quad T_o + (G \times \alpha - E) \times R_{so} \tag{1.14}$$

and the radiant emission is usually taken as between  $E = 90 \text{ W/m}^2$  for a cloudless sky and  $20 \text{ W/m}^2$  for a cloudy sky. For walls no such emission term is necessary, as these face surfaces of a similar temperature.

The heat flow through a sunlit opaque element will then be

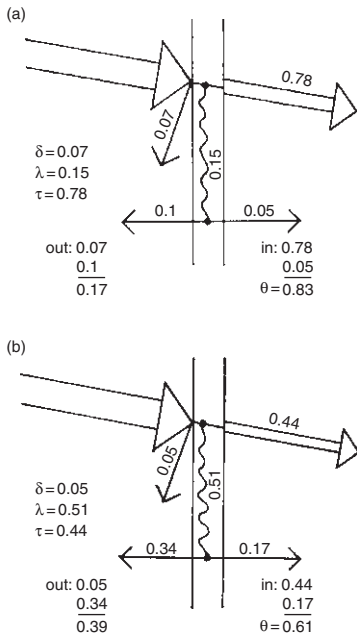
$$Q_c = A \times U \times (T_{s-a} - T_i).$$

The air temperature  $T_o$  is taken as the same all around but the  $T_{s-a}$  is different for each side of the building. It is therefore convenient to split this sol-air temperature into air temperature and sol-air excess temperature ( $dTe$ , in K) which is the temperature equivalent of the solar heat input, over and above the air temperature effect. The effect of air temperature is evaluated by the conduction expression ( $Q_c$ ), as Eq. (1.22), using  $q_c = \sum (A \times U)$  and  $\Delta T = T_o - T_i$  for the whole building and the extra heat flow caused by solar radiation will be calculated separately for each side:

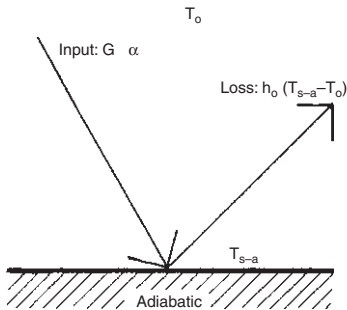
$$Q_s = q_c \times dTe \tag{1.15}$$

where  $dTe = (G \times \alpha - E) \times R_{so}$  for roofs;  $dTe = G \times \alpha \times R_{so}$  for walls and  $q_c$  is as defined by Eq. (1.22), taken for elements on that side.

There may be a situation where  $Q_c$  through an element is negative, but  $Q_s$  is positive.



**Fig. 1.47** Transmission through glass (a) clear 6-mm glass (b) heat absorbing (tinted) glass.



**Fig. 1.48** Derivation of the sol-air temperature.

### 1.4.2 Ventilation

The term 'ventilation' is used for three totally different processes and it serves three different purposes:

- (1) supply of fresh air, to remove smells, CO<sub>2</sub> and other contaminants,
- (2) remove some internal heat when  $T_o < T_i$ ,
- (3) to promote heat dissipation from the skin, i.e. physiological cooling.

The first two require quite small air exchange rates (volume flow rates,  $v_r$ , in m<sup>3</sup>/s or L/s), whilst for the last one it is the air velocity at the body surface, which is critical (in m/s).

Both deliberate ventilation and incidental air infiltration cause a heat flow, e.g. when in a heated building warm air is replaced by cold outside air. If the ventilation rate (volume flow rate,  $v_r$ ) is known, then the *ventilation conductance* (or specific ventilation heat flow rate) of the building can be found as

$$qv = 1200 \times v_r \quad (1.16)$$

where 1200 J/m<sup>3</sup>K is the volumetric heat capacity of moist air.

Often only the number of air changes per hour (N) is known (i.e. the number of times the total building volume of air is replaced in an hour), but from this the ventilation rate can be found:

$$v_r = N \times V/3600 \text{ (m}^3\text{/s)}$$

where V is the volume of the room or building (m<sup>3</sup>).  
substituting:

$$qv = 0.33 \times N \times V \quad (1.17)$$

where 0.33 is 1200/3600.

Incidental air infiltration in a poorly built house can be as much as  $N = 3$  air changes per hour, but with careful detailing and construction it can be reduced to  $N = 0.5$ . The fresh air, i.e. deliberate ventilation requirement (for the above purpose 1) is usually  $N = 1$  for habitable rooms,  $N = 10$  for a kitchen (when in use) but up to  $N = 20$  for some industrial situations or restaurant kitchens (see data sheet D.1.9).

The ventilation heat flow rate itself (which may serve the above purpose 2) will be

$$Q_v = qv \times \Delta T \quad (1.18)$$

where  $\Delta T = T_o - T_i$ .

In practice  $q_c$  and  $q_v$  are often added to get the *building conductance* (or building heat loss coefficient in some sources, a term that assumes a heat loss condition, whereas building conductance is valid for heat gain as well). (Note that this is not the same as 'conductance' (C) defined in Section 1.1.2.1.)

$$q = q_c + q_v \quad (1.19)$$

and then multiplied by  $\Delta T$  to get the total heat flow rate

$$Q = q \times \Delta T. \quad (1.20)$$

For purpose 3, physiological cooling, the apparent cooling effect of air movement ( $dT$ ) can be estimated as

$$\boxed{dT = 6 * v_e - 1.6 * v_e^2} \quad (1.21)$$

where the effective air velocity is  $v_e = v - 0.2$  and  $v$  is air velocity (m/s) at the body surface and the expression is valid up to 2 m/s.

### 1.4.3 Steady-state heat flow

**Internal gains** include any heat generated inside the building: the heat output of occupants, appliances and lighting. Data sheet D.1.8 gives the output of human bodies (at various activity levels) and of appliances. For both appliances and electric lighting the total consumption rate (power, in W) must be taken into account as heat output for the duration of their use (power  $\times$  time = energy,  $W \times h = Wh$ ).

For the purposes of steady-state analysis it is usual to take the daily average internal heat gain rate, i.e. add all gains for the day (in Wh) and divide it by 24 h to get the average rate in W.

**1.4.3.1 Conduction heat flow** is found as Eq. (1.1), except that the sum of  $A \times U$  products is found for the whole building envelope. This will be referred to as the *envelope conductance*

$$\boxed{q_c = \sum (A \times U)} \quad (m^2 \times W/m^2K = W/K). \quad (1.22)$$

This is the heat flow rate by conduction through the total envelope of the building with a  $\Delta T = 1$  K temperature difference between the inside and outside.

The resistance to heat flow of a layer of material is  $R = b/\lambda$ , i.e. thickness, divided by conductivity (see Section 1.1.2.1, Eqs (1.2) and (1.3)). For a multi-layer building element the resistances of all layers must be added. The surfaces provide additional resistances

(air-to-surface and surface-to-air) which must be added to this sum. Data sheet D.1.2 gives the appropriate surface resistance values ( $R_{si}$  and  $R_{so}$ ) for inside and outside surfaces. The reciprocal of this surface resistance is the surface conductance ( $h$ ), which is itself the sum of convective ( $h_c$ ) and radiative ( $h_r$ ) components. In each case the surface resistance is

$$R_s = 1/h = 1/(h_c + h_r) \text{ (in m}^2\text{K/W)}.$$

Any cavity or air gap may also offer a resistance ( $R_c$ ), thus the air-to-air resistance of an element will be

$$R_{a-a} = R_{si} + R_1 + R_2 + R_c + \dots + R_{so}$$

where  $R_1, R_2$  = resistance of material layers;  $R_c$  = the resistance of any cavity. Data sheet D.1.2 gives also cavity resistance values. The U-value is the reciprocal of this  $R_{a-a}$ . U-values of many elements are given in data sheets D.1.3 and D.1.4, but it can also be calculated from its component resistances.

The actual total conduction heat flow rate of the building will be

$$Q_c = q_c \times \Delta T \quad (\text{W/K} \times \text{K} = \text{W}). \quad (1.23)$$

or

$$Q_c = \sum (A \times U) \times \Delta T$$

where  $\Delta T = T_o - T_i$ , the difference between outside and inside air temperature.  $Q_c$  is negative for heat loss and positive for heat gain.

**1.4.3.2 Insulation** means the control of heat flow, for which three different mechanisms can be distinguished: reflective, resistive and capacitive.

**Reflective insulation:** where the heat transfer is primarily radiant, such as across a cavity or through an attic space; the emittance of the warmer surface and the absorptance of the receiving surface determine the heat flow. A shiny aluminium foil has both a low emittance and a low absorptance, it is therefore a good reflective insulator. It will be effective only if it is facing a cavity, so it does not itself have an R-value, but it modifies the R-value of the cavity. For example, a cavity, at least 25 mm wide, in a wall would have the following resistances:

- with ordinary building materials  $0.18 \text{ m}^2\text{K/W}$
- if one surface is lined with foil  $0.35$
- if both surfaces are lined with foil  $0.6$  (see data sheet D.1.2 for further data).

A reflective surface in contact with another material would have no effect, as heat flow would take place by conduction.

An often asked question (in hot climates) is: what would be more effective to reduce downward heat flow in an attic space, to have a foil (a) on top of the ceiling, with its face upwards (relying on its low absorptance) or (b) under the roof skin, with face down (relying on its low emittance). The two would be equally effective, when new. However, in less than a year the foil over the ceiling would be covered in dust, so its low absorptance destroyed, therefore solution (b) would be better in the long run.

In a hot climate, where the downward heat flow is to be reduced, this solution (b) could be very effective, but almost useless in a cold climate, in reducing upward heat flow. Here, the top of the ceiling (of a heated room) is warm, will heat the air adjacent to it, which will then rise and transmit its heat to the underside of the roof. So the upward heat transfer is dominantly convective, unaffected by the foil. In the first case, the downward heat transfer is primarily radiant: the heated air will remain adjacent to the roof skin, as it is lighter than the rest of the attic air, so there will be practically no convective transfer.

On this basis some authors suggest that in a hot climate such a foil insulation under the roof skin is preferable to resistive insulation. It will reduce downward heat flow, but will allow the escape of heat at night, thus permitting building to cool down; act practically as a 'thermal diode'. A resistive insulation would affect the up and down heat flow almost equally.

**Resistive insulation:** of all common materials, air has the lowest thermal conductivity:  $0.025 \text{ W/m} \cdot \text{K}$  (other values are given in data sheet D.1.1), as long as it is still. In a cavity, convection currents will effectively transfer heat from the warmer to the cooler face. The purpose of resistive insulation is just to keep the air still, dividing it into small cells, with the minimum amount of actual material. Such materials are often referred to as 'bulk insulation'. The best ones have a fine foam structure, consisting of small closed air cells separated by very thin membranes or bubbles, or consist of fibrous materials with entrapped air between the fibres.

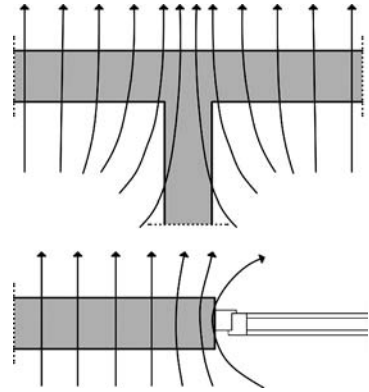
The most often used insulating materials are expanded or extruded plastic foams, such as polystyrene or polyurethane or fibrous materials in the form of batts or blankets, such as mineral wool, glass fibres or even natural wool. Loose cellulose fibres or loose exfoliated vermiculite can be used as cavity fills or poured over a ceiling. Second class insulators include wood wool slabs (wood shavings loosely bonded by cement), wood fibre softboards and various types of lightweight concrete (either using lightweight aggregate or autoclaved aerated concrete).

Heat flow into (and out of) buildings is driven by two external (climatic) forces: air temperature and solar radiation. The expressions used for calculating these heat flows are summarised in Table 1.3.



**Table 1.3** Summary of steady-state heat flow expressions

Air temperature		Solar radiation	
Ventilation	All elements	Opaque elements	Windows
$Q_v = q_v \Delta T$ $q_v = 1200 \text{ vr}$ $= 0.33 \text{ V N}$ $\Delta T = T_o - T_i$	$Q_c = q_c \Delta T$ $q_c = \sum (A U)$ $\Delta T = T_o - T_i$	$Q_{so} = q_c dTe$ $q_c = \sum (A U)$ $dTe = G \alpha R_{so}$ roof: $(G \alpha - E) R_{so}$	$Q_{sw} = A G \theta$
$Q = (q_c + q_v) \Delta T + Q_{so} + Q_{sw}$			



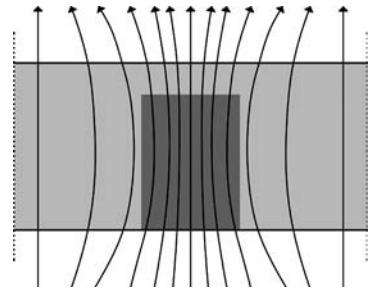
**Fig. 1.49** Thermal bridges due to geometry.

**1.4.3.3 Thermal bridges: multidimensional steady-state heat flow** is an often ignored phenomenon, although known before, seriously only considered in recent years. In the above discussion the assumption was made that heat flows through an envelope element with the flow path being perpendicular to the plane of that element, i.e. the phenomenon is analysed as a *one-dimensional heat flow*. This is true only for infinitely large elements with parallel plane surfaces and uniform cross-section. The results obtained with calculation techniques presented above are therefore approximate only.

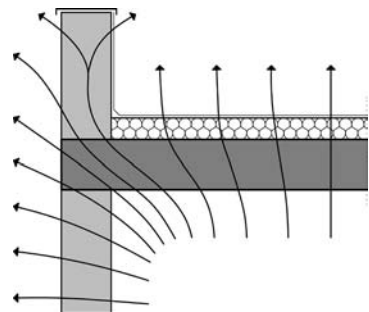
In real building elements the criteria of one-dimensional heat flow are often not satisfied. Where the boundaries are other than plane parallel surfaces, or the material is not homogeneous, two- or three-dimensional heat flows develop. Areas where increased, multidimensional heat flow occurs are called *thermal bridges*. These may be consequences of the geometric form (Fig. 1.49), including corner effects, the combination of materials of different conductivities (Fig. 1.50), or both (Fig. 1.51).

*Temperature distribution around thermal bridges* can be visualised if we consider that heat flow will take place along the shortest path, the path of least resistance. In Fig. 1.52, the resistance along flow path 1 is less than it would be along a line perpendicular to the surface, due to the higher conductivity of the column. Along flow path 2 the resistance is less, due to the bigger 'cross section', not 'occupied' by other flows. In a heat loss situation the heat flow density will be greater at thermal bridges, therefore the surface temperature increased outside and reduced inside.

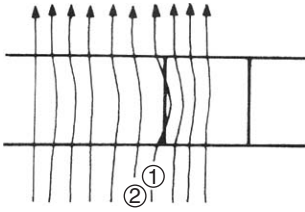
Heat flows in the direction of the steepest temperature gradient, as water flows in the direction of the steepest slope (Fig. 1.53). Thus the heat flow paths are at right angles to the isotherms (an isotherm is the locus of points of equal temperature). In Fig. 1.54 the density of heat flow paths indicates an increased heat flow, whilst the isotherms show an increased outside surface temperature at the column and a reduced inner surface temperature.



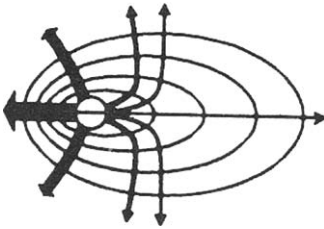
**Fig. 1.50** Thermal bridge in mixed construction.



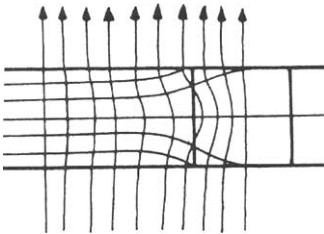
**Fig. 1.51** The two effects (of both Figs 1.49 and 1.50) combined.



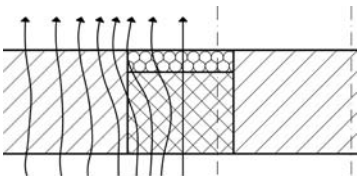
**Fig. 1.52**  
A concrete column in a brick wall: path 1 offers less resistance than the straight line.



**Fig. 1.53**  
Heat flow 'downhill'.



**Fig. 1.54**  
Temperature distribution near a thermal bridge (isotherms and flow paths).



**Fig. 1.55**  
Flow paths when column is insulated.

If, as in Fig. 1.55, an insulating element is inserted (here: on the outside face of the concrete column), which blocks the heat flow, the temperature in the highly conductive column will be higher than in the adjoining wall, therefore a sideways heat flow will occur, increasing the flow density near the column. The outside surface temperature over the insulating insert will be lower and next to this insert higher than that of the plain wall.

As a rule of thumb, the effect of thermal bridges diminishes to negligible levels beyond a strip with width twice that of the wall thickness. If the wall thickness is 300 mm, the width of this strip is approx. 600 mm, in both directions from the edge. Viewing a usual room-size facade element and marking these strips along the joints, it can be seen that there is no area on this element that would be free of thermal bridge effects and of multidimensional temperature distribution (Fig. 1.56). For further discussion of thermal bridges see Section 1.5.1 and D.1.5.

Capacitive insulation will be considered in the following section.

#### 1.4.4 Dynamic response of buildings

**Capacitive insulation**, i.e. material layers of a high thermal capacity (massive construction) affect not only the magnitude of heat flow, but also its timing. Both reflective and resistive insulation respond to temperature changes instantaneously. As soon as there is a heat input at one face, a heat output on the other side will appear, albeit at a controlled rate. Not so with capacitive insulation. This relies on the thermal capacity of materials and their delaying action on the heat flow.

In a non-steady, randomly varying thermal environment the tracing of heat flows requires sophisticated and lengthy calculation methods, which are feasible only if included in computer programs. There is a sub-set of non-steady heat flow regimes, the *periodic heat flow*, the analysis of which is quite easy. Fortunately, most meteorological variables (temperature, solar radiation) show a regular variation, a repetitive 24-h cycle. The following discussion relates to such a periodic heat flow analysis.

**Periodic heat flow** is illustrated in Fig. 1.57, over a 24-h period. The solid line is the heat flow through an actual masonry wall and the dashed line is the heat flow through a 'zero-mass' wall of the same U-value. This curve would be the result if we calculated the heat flow by a steady-state method for each hour and connected the points.

Both curves show a 24-h cycle, but they differ in two ways:

1. The actual heat flow curve is delayed behind the zero-mass curve by some time. This delay of the peak of the solid curve behind the peak of the dashed-line curve is referred to as the *time-lag*, (or phase-shift, denoted  $\phi$ ) measured in hours.

2. The amplitude or swing of the peak from the daily average heat flow is smaller for the solid line (sQ), than for the dashed line showing the wall of zero mass (sQ<sub>0</sub>). The ratio of the two amplitudes is referred to as the *decrement factor*, or amplitude decrement, denoted μ:

$$\mu = \frac{sQ}{sQ_0}$$

A similar diagram could be drawn with temperature on the vertical scale. The dashed line would then show temperatures of the outer surface and the solid line indicating temperatures at the inside surface. From this the same two properties could be derived.

The calculation of these two properties is fairly involved, particularly for multilayer elements, but data sheets D.1.3 and 4 give these values for numerous everyday constructions, alongside their U-values. Fig. 1.58 shows the time lag and decrement factor properties of solid, homogeneous massive walls (brick, masonry, concrete or earth) and the effect of insulation applied to the inside or the outside of the massive wall.

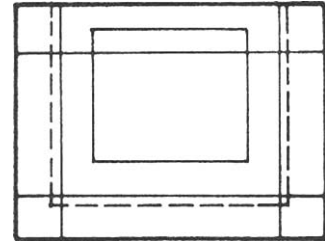
If we take a 220 mm brick wall with a U-value of 2.26 W/m<sup>2</sup>K and take a polystyrene slab of about 10 mm thickness, which would have about the same U-value, under steady-state conditions the heat flow through these two would be identical and calculations based on steady-state assumptions would give the same results.

In real life their behaviour will be quite different. The difference is that the brick wall has a surface density of about 375 kg/m<sup>2</sup> and the polystyrene slab only some 5 kg/m<sup>2</sup>. The respective thermal capacities would be 300 kJ/m<sup>2</sup> and 7 kJ/m<sup>2</sup>. In the brick wall each small layer of the material will absorb some heat to increase its temperature before it can transmit any heat to the next layer. The stored heat would then be emitted with a considerable time delay.

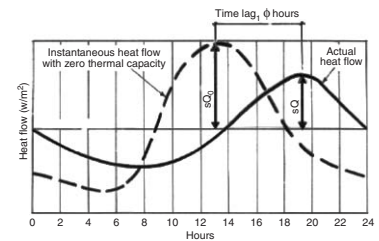
A time sequence of temperature profiles through this wall is shown in Fig. 1.59. It can be observed that from evening hours onwards the middle of the wall is the warmest and the stored heat will also start flowing backwards. So (assuming inward heat flow) only a part of the heat that had entered the outside surface will reach the inside surface. In the polystyrene slab the temperature profile would be a sloping straight line moving up and down as the temperature changes on the input side.

The procedure to calculate periodic heat flow consists of two parts, e.g. for a solid element:

- (1) find the daily mean heat flow,  $\bar{Q}_c$ ;
- (2) find the deviation from (or swing about) this mean flow for time (hour) 't' of the day:  $sQ_{ct}$ .



**Fig. 1.56**  
The whole area of a wall module is affected by thermal bridges: strips affected by the perimeter and by the window junction (dashed line).

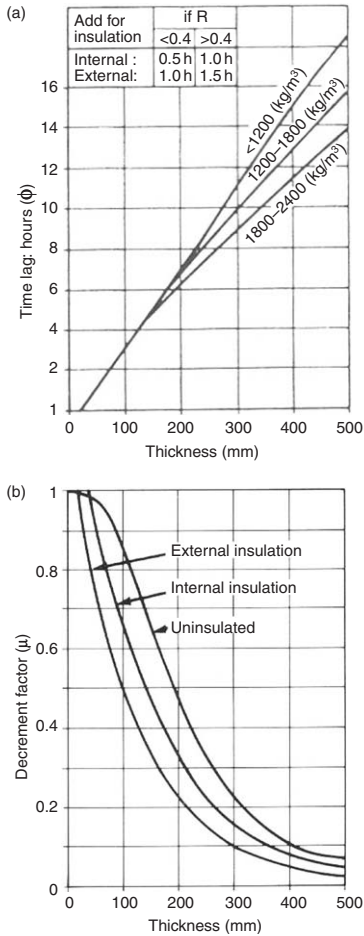


**Fig. 1.57**  
Heat flow through a real wall, compared with a wall of zero mass.

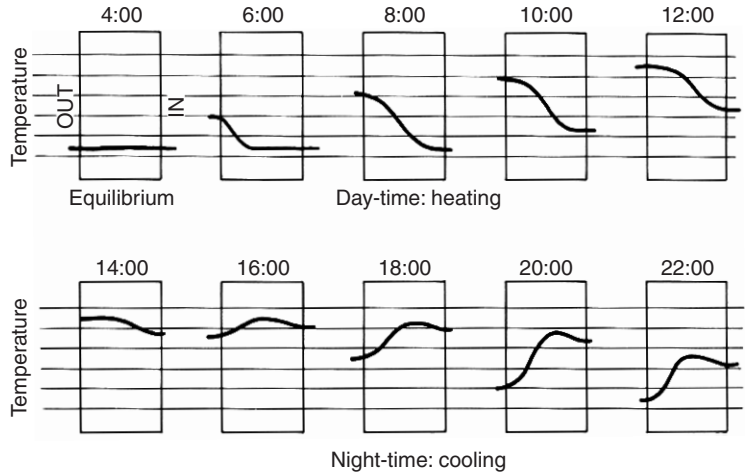
First find the mean sol-air temperature of the outside surface:  $\bar{T}_{s-a}$ , then find the mean temperature difference  $\Delta\bar{T}$ , then  $\bar{Q}_c = qc \times \Delta\bar{T}$ . Then calculate the swing in heat flow at time  $t$  due to the deviation of conditions  $\phi$  hours earlier (at time  $t-\phi$ ) from the day's average.

$$sQ_{c_t} = qc \times \mu \times (T_{s-a(t-\phi)} - \bar{T}_{s-a}) \tag{1.24}$$

E.g. if the calculation is done for 14:00 h and  $\phi = 5$  h, then take the sol-air temperature at 14 - 5 = 9 o'clock ( $T_{s-a;9:00}$ ). The heat flow at time  $t$  will then be  $Q_{c_t} = \bar{Q}_c + sQ_{c_t}$ .



**Fig. 1.58**  
Time-lag and decrement factors for solid homogeneous walls.



**Fig. 1.59**  
Time sequence of temperature profiles in a massive wall (in a warm climate).

**Table 1.4** Expressions for the swing in heat flow

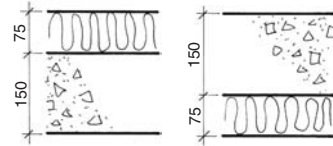
	Building parameter	Environmental parameter
1 Ventilation	$sQ_v = qv$	$\times (T_{o,t} - T_{o,av})$
2 Conduction, glass	$sQ_{c_g} = A \times U$	$\times (T_{o,t} - T_{o,av})$
3 Conduction, opaque	$sQ_{c_o} = A \times U \times \mu$	$\times (T_{o(t-\phi)} - T_{o,av})$
4 Solar, glass	$sQ_{s_g} = A \times \theta_a$	$\times (G_t - G_{av})$
5 Solar, opaque	$sQ_{s_o} = A \times U \times \mu \times \alpha \times R_{so}$	$\times (G_{t-\phi} - G_{av})$
6 Internal gain	$sQ_i = Q_{i_t} - Q_{i_{av}}$	

where  $\mu$  = decrement factor,  $\phi$  = time-lag,  $\theta_a$  = alternating solar gain factor  $qv = 0.33 \times N \times V$  or  $1200 \times vr$  ( $N$  = number of air changes,  $vr$  = volume rate).

The deviation from the mean heat flow rate ( $sQ_{c_t}$ ) at time  $t$  can be calculated on the basis of Eq. (1.24). Table 1.4 summarises the six components of such flow swing. Items 4 and 5 will have to be repeated for each envelope element of different orientation.

The benefits of capacitive insulation (or mass effect) will be greatest in hot-dry climates, which show large diurnal temperature variations. Some sources suggest that a mean range (the range between monthly mean maximum and minimum, averaged for the 12 months) of 10 K would warrant heavy construction, others put this limit at 8 K. Capacitive insulation has a dampening, stabilising effect, it can improve comfort or, if the building is conditioned, produce energy savings.

The dynamic properties (time-lag, decrement factor and admittance) of multilayer elements depend not only on the material and thickness of layers, but also on the sequence of these layers with respect to the direction of heat flow. This is best illustrated by an example (Fig. 1.60):



**Fig. 1.60** Sequence of layers in an insulated concrete roof slab.

**Example 1.3**

Take a roof slab of 150 mm reinforced concrete, with 75 mm of EPS insulation (the waterproof membrane is thermally negligible) and consider a summer (heat gain) situation.

the air-to-air resistance will be

$$R_{a-a} = R_{so} + R_{EPS} + R_{CONCR} + R_{si}$$

$$= 0.04 + \frac{0.075}{0.035} + \frac{0.150}{1.4} + 0.14 = 2.43$$

$$U = 1/R_{a-a} = 1/2.43 = 0.41 \text{ W/m}^2\text{K}$$

This is the same, regardless of the sequence of layers, but for dynamic properties:

	$\phi$	$\mu$	$Y_{inside}$
EPS externally	6.28 h	0.3	5.41 W/m <sup>2</sup> K
EPS internally	5.03 h	0.56	0.44
Difference	1.25 h	0.26	4.97

The last column (Y) is the admittance of the element, which is the measure of its ability to pick up (and release) heat from the indoors, as the temperature changes (swings). Y has a strong influence when indoor temperatures are to be calculated which result from the heat flows.

The total admittance of a building (or of a room) is

$$q_a = \sum (A \times Y) \text{ in W/K.}$$

The EPS externally produces a time lag some 1.25 h longer, reduces the decrement factor to a little over half and gives an inside surface admittance some  $4.97 \text{ W/m}^2\text{K}$  more than the reverse order of layers. So, the mass inside of a resistive insulation will reduce the heat gain, delay it more and result in a more stable indoor temperature.

For the calculation of time-lag, decrement factor and admittance for solid homogeneous elements (and other thermal indices) see Method sheet M.1.8.

**1.4.4.1 Thermal response simulation** of buildings became an everyday design tool with the rapid development of computers, since the 1970s. PCs are now more powerful than the early main-frame computers and can run the most sophisticated simulation programs. Relatively simple programs have been produced, which use basically steady-state type calculations adding some 'fudge factor' to approximate dynamic behaviour (e.g. QUICK (recently renamed 'Building Toolbox'), or BREDEM = BRE domestic energy model). A number of programs are based on the time-lag and decrement factor concepts introduced above (a harmonic analysis), using the 'admittance procedure' of the UK BRE (e.g. ADMIT and ARCHIPAK). These analyse the dynamic thermal response, but in a strict sense, do not 'simulate' the various heat flows. Some complex mathematics is involved in finding the time-lag and other dynamic thermal properties of envelope elements, but when these are known, it is only simple number crunching.

There are numerous programs which trace the heat flow hour-by-hour through all components of the building, using an annual hourly climatic data base (such as those mentioned in Section 1.3.3). These can predict hourly indoor temperatures or the heating/cooling load if set indoor conditions are to be maintained. Some go further and simulate the mechanical (HVAC) systems, thus predict the energy consumption for the hour, the day, the month or the year. The most sophisticated of these is ESPr, of the University of Strathclyde (said to solve up to 10 000 simultaneous differential equations), and the most widely used one is the US DoE-2. The latter is now available to run under Windows, as 'Visual DoE' or DoE 3.1.

More detailed discussion of this topic is outside the scope of this work.

**1.4.4.2 Application.** *The whole is more than the sum of its parts* – a statement as true for the thermal behaviour of buildings as in perception psychology.

In perception psychology there are two main schools of thought: the behaviourists analyse simple stimulus–reaction relationships and try to build up an overall picture from such building

blocks, whilst followers of the Gestalt school profess that the 'configuration', the totality of experience, the interaction of all sensory channels is important. In a similar way one can discuss the thermal effect of individual building components, but the thermal behaviour of any building will be the result of the interaction of all its elements, of the climate-building-services-user relationship. In this sense we can speak of the 'thermal Gestalt' of a building.

A simple example of this interdependence is the question of roof insulation in a warm climate. There is no doubt that increased roof insulation would reduce daytime (solar) heat gain, but it will also prevent nighttime dissipation of heat. Only a careful analysis will give the right answer, the best for both situations.

One can quote the example of equator-facing windows, which are desirable in winter, but if the building is lightweight, without adequate thermal storage mass, the resulting heat gain may produce overheating during the day; the user will get rid of this by opening the windows, so there will be no heat left to soften the coldness of the night.

In some texts the use of skylights is advocated as an effective energy conservation measure. It is undoubtedly useful for daylighting, but it produces more solar heat gain in the summer (with high angle sun) than in winter, and in winter in most cases it will be a net loser of energy. It depends how it is done.

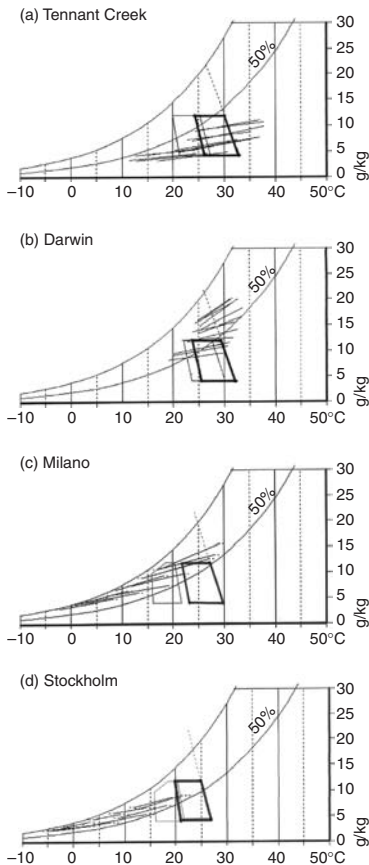
Over the last ten years – or so – there was a battle raging over the usefulness of courtyards in hot dry climates. Both the protagonists and adversaries produced measured results. The resolution is that it depends on how the courtyard is treated. It can be either good or bad.

The answer to any simple question is usually quite complicated, and most of it is of the 'if . . . then . . . ' type. When the designer asks what the width of the eaves of a house should be, the answer can only be: 'It depends . . . ' and a long sequence of counter-questions, such as where is the house? in what climate? what is the overheated period? what is the orientation? is it single or double storey? is a window considered or a door with glass down to floor level?

The architect must make thousands of (larger or smaller) decisions during the design of even the simplest building. There is no time to analyse every single question in detail. However, the analytical attitude is important. The designer working in a given climate, given culture and the given building industry, will probably examine such questions once and remember the answer. Many such answers derived from serious analysis will enrich his/her experience. Accumulated experience (including experience of failures or the experience of others) may make quick decisions possible but would also suggest what factors, what conditions would have a bearing on a given question. And this is what constitutes professional know-how.



## 1.5 Thermal design: passive controls



**Fig. 1.61**

Plots of four climates vs comfort zone. (a) Hot-Dry: a very dry climate with large diurnal ranges (long lines), hot summer, cool winter nights.

(b) Warm-Humid: little variation in comfort between summer and winter; short lines, most of them above the 12 g/kg limit.

(c) Temperate: comfortable summer, cool winter; large seasonal difference in comfort.

(d) Cold: large seasonal difference in comfort conditions, the monthly climate lines rarely reach the comfort zone.

The first step in any bioclimatic design approach is to examine the given climate and establish the nature of the climatic problem: relate the climate to human requirements. A good way of doing this is to use the psychrometric chart as the base.

Once the comfort zone for winter and summer has been plotted (as in Section 1.2.4, Fig. 1.21), the climate can be plotted on the same diagram.

Mark on the chart two points for each of the 12 months: one using the mean maximum temperature with the afternoon RH and one using the mean minimum temperature with the morning RH. Connect the two points by a line. The 12 lines thus produced would indicate the median zone of climatic conditions. The relationship of these lines to the comfort zone indicates the nature of the climatic problem.

Lines to the right of the comfort zone indicate overheating, to the left underheating. Lines above the 12 g/kg limit indicate that humidity may be a problem. Long lines indicate large diurnal variations, short ones are characteristic of humid climates with small diurnal variations.

Fig. 1.61 shows four such psychrometric plots for each of the four basic climate types.

The next step would then be the choice of passive control strategy. Four basic strategies can be distinguished, with some subdivisions in each.

- (1) passive solar heating (with efficiency or utilizability of e.g. 0.5 and 0.7);
- (2) mass effect (summer and winter + for summer also with night ventilation);
- (3) air movement (physiological cooling) effect, e.g. for 1 and 1.5 m/s;
- (4) evaporative cooling (direct and indirect).

### 1.5.1 Passive control of heat flows

In climates where there is a large temperature difference between the inside and the outside (the climate lines extend far from the comfort zone), where some form of heating or cooling will be necessary, thermal insulation of the envelope is the most important means of control. In most countries there are regulatory requirements for the insulation of envelope elements, walls, roofs and windows. These may stipulate a maximum U-value (which must not be exceeded) or a minimum R-value ( $R_{a-a}$ ) which must be achieved by the construction.



**Example 1.4**

Assume that we propose to have a 260 mm cavity brick wall (105 + 50 + 105), with 10 mm plastering on the inside. Conductivities are:

facing brick (outer skin):	$\lambda = 0.84 \text{ W/m K}$
inner skin of brick:	$\lambda = 0.62$
plastering	$\lambda = 0.5$
inside $R_{si}$	$= 0.12 \text{ m}^2 \text{ K/W}$
10 mm plastering $0.010/0.5$	$= 0.02$
105 mm inner brick $0.105/0.62$	$= 0.17$
cavity $R_c$	$= 0.17$
105 mm outer brick $0.105/0.84$	$= 0.12$
outside surface $R_{so}$	$= 0.06$
$R_{a-a}$	$= 0.66$
$U$	$= 1/0.66 = 1.56 \text{ W/m}^2\text{K}$

The regulations require (say)

$$U < 0.8 \text{ W/m}^2\text{K} \quad R_{a-a} > 1/0.8 \quad \underline{1.25}$$

$$\text{additional R required: } 1.25 - 0.66 = 0.59$$

Consider using EPS boards inside the cavity, held against the inner skin of brick, which has a conductivity of  $\lambda = 0.033 \text{ W/mK}$ . The required thickness ( $b$  for 'breadth') will be: as  $R = b/\lambda$

$$\text{We need } 0.59 \text{ m}^2\text{K/W} = b/0.033 \quad b = 0.59 \times 0.033 = 0.0195$$

that is we must install a 20 mm EPS board.

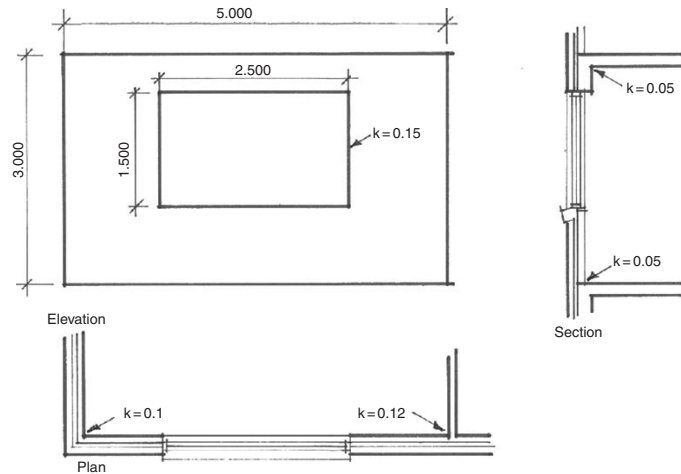
This method can be generalised, that is, we can take the resistance of the construction selected for reasons other than thermal and find the additional resistance required. From that the necessary thickness of added insulation can be found.

Thermal bridge effects (discussed in Section 1.4.3.3) can be allowed for by using linear heat loss coefficients,  $k$  (see data sheet D.1.5) in addition to the  $U$ -value-based calculation. Dimensionally, these coefficients are  $\text{W/m}\cdot\text{K}$  and are to be multiplied by the length, to give  $\text{W/K}$ . This is illustrated by an example:

**Example 1.5**

Assume that a wall element of 5 m length and 3 m height is at the corner of a building and it incorporates a window of  $2.5 \times 1.5 \text{ m}$  dimensions. There is an internal partition joining at the other end. The wall is of the construction examined above ( $U = 0.8 \text{ W/m}^2\text{K}$ ) and the window is double glazed, with a  $U$ -value of  $3.6 \text{ W/m}^2\text{K}$  (Fig. 1.62).

$$\text{The wall is } 5 \times 3 = 15 \text{ m}^2 \text{ less the window: } 2.5 \times 1.5 = 3.75 \text{ m}^2 \text{ net wall area} = 11.25 \text{ m}^2.$$



**Fig. 1.62**  
Locations of thermal bridges: linear heat loss coefficients ( $k$ ).

The  $A \times U$  products are: wall  $11.25 \times 0.8 = 9 \text{ W/K}$   
 window  $3.75 \times 3.6 = 13.5$   
 $22.5 \text{ W/K}$

The following linear losses must be added (values from D.1.5):

for the window perimeter  $8 \text{ m} \times 0.15 = 1.2$

for the outer corner  $3 \text{ m} \times 0.1 = 0.3$

for the wall / partition junction  $3 \text{ m} \times 0.12 = 0.36$

for the wall / floor slab joints  $2 \times 5 \text{ m} \times 0.06 = \frac{0.6 \text{ W/K}}{2.46 \text{ W/K}}$

so the average U-value will be

$$U_{\text{av}} = \frac{22.5 + 2.46}{15} = 1.66 \text{ W/m}^2 \text{ K}$$

in a generalised form:  $U_{\text{av}} = \frac{\Sigma(A \times U) + \Sigma(L \times k)}{\Sigma A}$

where  $L$  is the length of each linear component.

A quick look at any table of U-values would show that the weakest point of any building envelope is the window. Whilst even an uninsulated brick wall (as in Example 1.4) would have a U-value around  $1.5 \text{ W/m}^2 \text{ K}$ , an ordinary single-glazed window would be about four times as much,  $5.5 - 6.5 \text{ W/m}^2 \text{ K}$ . The U-value

of a window depends on

- (1) the glazing            single, double, low-e, etc;
- (2) the frame            wood, metal, discontinuous metal;
- (3) frame thickness    10%–30% of the elevational area of  
   the window;
- (4) exposure            sheltered, normal, exposed.

A window with a sealed double glazing unit would have a U-value of 2.7 to 4.5 W/m<sup>2</sup>K, depending on the frame. A wood frame has a lower U-value than a metal one, but the latter can be improved by a built-in discontinuity (which would break the thermal bridge effect of the frame).

A low emittance coating inside a sealed double glazing unit would reduce the radiant heat transfer and a low pressure inert gas (krypton or argon) fill (partial vacuum) would reduce the conductive transfer. Such glazing, with a discontinuous 10% metal frame (where the frame takes up 10% of the overall window area) would have a U-value lower than 2.0 W/m<sup>2</sup>K.

A good window must perform five functions:

- (1) provide a view,
- (2) admit daylight,
- (3) reduce heat loss,
- (4) admit solar heat (in a cold situation),
- (5) allow controllable ventilation.

In a cold situation a large window may be a liability. It would cause a large heat loss, but it could also produce a significant solar heat gain. A comparison can be made between heat loss and gain in a very simple way, based on a unit area of window.

#### Example 1.6

Taking Canberra as an example, calculate the gains and losses over a day of the coldest month (July). Comparison can be made for a unit area:

$$T_{o,av} = 5.8^{\circ}\text{C}. \text{ Take } T_i \text{ as } 23^{\circ}\text{C}, \text{ thus the } \Delta T \text{ is } 17.2 \text{ K}$$

Take a single-glazed window:  $U = 5.3 \text{ W/m}^2 \text{ K}$  and solar gain factor:  $\theta = 0.76$

orientation: North, daily vertical irradiation  $D_{v,360} = 2801 \text{ Wh/m}^2$

Assume a solar 'efficiency' (utilizability) of 0.7

$$\text{GAIN: } 2801 \times 0.76 \times 0.7 = 1490 \text{ Wh/m}^2$$

$$\text{LOSS: } 5.3 \times 17.2 \times 24 = 2188$$

Loss > Gain, thus the window is not beneficial.

However, if double glazing is used,  $U = 3 \text{ W/m}^2\text{K}$ ,  $\theta = 0.64$

GAIN:  $2801 \times 0.64 \times 0.7 = 1255 \text{ Wh/m}^2$

LOSS:  $3 \times 17.2 \times 24 = 1238$

Loss < Gain, thus it is beneficial (marginally).

If we look at the same window, facing East:

$D_{v90} = 1460 \text{ Wh/m}^2$

GAIN:  $1460 \times 0.64 \times 0.7 = 654 \text{ Wh/m}^2$

LOSS: same as above = 1238

Loss  $\gg$  Gain  $\therefore$  the window would be a liability.

The situation changes if we use an insulating shutter overnight. Assume one that would reduce the U-value with single glazing to 1.5 and with double glazing to  $1.3 \text{ W/m}^2\text{K}$  and that it would be closed for 14 h. The gain is the same as above. The loss will be

Single glazing:  $(1.5 \times 14 + 5.3 \times 10) \times 17.2 = 1272 \text{ Wh/m}^2$   $1490 > 1272 \therefore \text{OK}$

Double glazing:  $(1.3 \times 14 + 3 \times 10) \times 17.2 = 829$   $1255 > 829 \therefore \text{OK}$

**1.5.1.1 Passive solar heating** in its simplest form requires no more than a good window facing the equator. An appropriate horizontal shading device could provide shading in the summer but allow the entry of solar radiation in the winter (see Fig. 1.45). Adjustable shading could also be considered. The performance of such a system would also depend on the available thermal storage mass. In a lightweight building the solar heat input would overheat the interior, which may lead to discomfort, but also to a large heat loss.

Heavy walls and floor (especially where it is reached by the solar beam) would absorb much heat, reduce the overheating and the stored heat would be released at night. The mass need not be very much. For the 24-h cycle the depth of heat penetration (the effective storage, where the heat input and release surface is the same, so there would be a cyclic reversal of heat flow) may not be more than 100–120 mm.

A massive wall exposed to solar radiation would also act as a heat collector and storage device, but much heat would be lost through the outside surface, both whilst it is heated by the sun and after sunset. Such loss could be reduced by a glazing or a transparent insulation cover on the outside. This would be recognised as a passive solar 'mass wall' heating system. However, as the wall surface behind the glass is heated, it will heat the air in the gap and cause a large heat loss, backwards, through the glazing.

This can be reduced by the 'Trombe–Michel'<sup>ss</sup> system (Fig. 1.63), which incorporates vent openings near the floor and near the ceiling. As the heated air rises, it would enter the room through the top vent, drawing in cooler air from the room near the floor level, forming a thermosiphon circulation. Thus the outer wall surface and cavity air temperatures are lowered, thereby the heat loss is reduced.

Another passive solar heating system is the 'attached greenhouse'. This can be considered as an enlargement of the air gap of the above system (of about 100 mm) to perhaps 2 m or more. The thermal function is the same as for the Trombe–Michel wall, but whilst it heats the room behind it, it also provides a useable space for plants and even for sitting, as a 'winter garden' or conservatory. At night such a greenhouse can lose much heat, so it is essential to provide for closing off the room it serves, or else it becomes a net loser of heat.

The passive solar heating **potential** (by whatever system) can be estimated on the following basis:

The critical parameter is solar radiation on the equator-facing vertical surface, for the average day of the coldest month ( $D_v$ ). Find the lowest temperature at which the solar gain can match the heat losses. The limiting condition will be when the solar heat input equals the heat loss:

$$D_v \times A \times \eta = q \times (T_i - T_o) \times 24$$

where  $D_v$  = vertical irradiation (Wh/m<sup>2</sup>day)  
 $A$  = area of solar aperture  
 $\eta$  = efficiency (utilizability), taken as 0.5 or 0.7  
 $q$  =  $q_c + q_v$ , building conductance (W/K)  
 $T_i$  = indoor temperature limit, taken as  $T_n - 2.5$   
 $T_o$  = the limiting temperature to be found

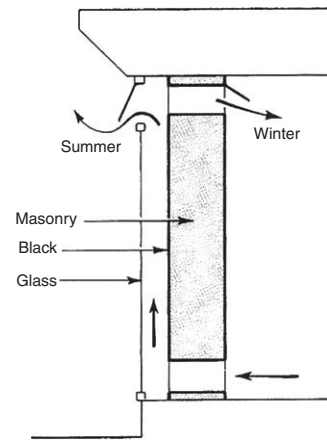
Assume a simple house of 100 m<sup>2</sup> floor area and 20% (=20 m<sup>2</sup>) solar window and a building conductance of 115 W/K. Substituting:

$$D_v \times 20 \times 0.5 = 115 \times (T_i - T_o) \times 24;$$

rearranging for  $T_o$ ,

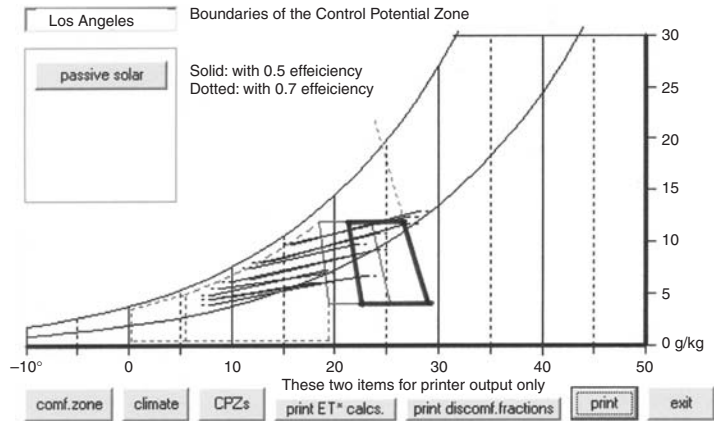
$$T_i - T_o = D_v \times 20 \times 0.5 / (115 \times 24) = D_v \times 0.0036;$$

$$T_o = T_i - 0.0036 \times D_v.$$



**Fig. 1.63**  
Principles of the Trombe–Michel wall.

<sup>ss</sup> named after Jacques Michel (architect) and Felix Trombe (physicist).



**Fig. 1.64**  
CPZ for passive solar heating.

### Example 1.7

if in Canberra in July

$D_{v,360} = 2801 \text{ Wh/m}^2$  and  $T_{o,av} = 5.3^\circ\text{C}$ ,  $T_n = 19.2^\circ\text{C}$  thus  $T_i = 16.7^\circ\text{C}$  then with  $\eta = 0.5$  the lowest  $T_o$  that the solar gain can compensate for:

$$T_o = 16.7 - 0.0036 \times 2801 = 6.6^\circ\text{C}$$

or with  $\eta = 0.7$

$$T_o = T_i - 0.005 \times D_v$$

$$T_o = 16.7 - 0.005 \times 2801 = 2.7^\circ\text{C}$$

which means that down to  $6.6^\circ\text{C}$  (or  $2.7^\circ\text{C}$ ) outdoor temperature the passive solar heating system has the *potential* of keeping the indoors comfortable.

This example is illustrated by Fig. 1.64, showing the Control Potential Zone (CPZ) for passive solar heating

**1.5.1.2 The mass effect** provided by a heavy construction is beneficial in many situations, even without any such special devices:

In a cold climate, for a continuously occupied building (e.g. a house or a hospital), where it would allow the use of intermittent heating and still keep a stable temperature. In an intermittently used and heated building (an office or a school) lightweight (insulated) construction may be better. Massive construction would have a longer heating-up period in the morning and the stored heat would be dissipated overnight, thus wasted.

The same argument is valid for an air-conditioned building in a hot-humid climate, where even the nights are too warm.

The 'mass effect' is one of the most important passive control strategies. If there is a storage mass, it can be manipulated according to the climatic needs. In a typical hot-dry climate, with a large diurnal variation, where the temperature varies over the daily cycle between too high and too cold, (where the day's mean is within the comfort zone) massive construction may provide the full solution, it may ensure comfortable indoor conditions without any mechanical cooling (or night heating).

What is the definition of a 'massive, heavyweight' and a 'light-weight' building? The criterion may be the *specific mass* of the building:

$$sM = \frac{\text{total mass of the building}}{\text{floor area of the building}} \quad (\text{kg/m}^2)$$

or the CIBSE 'response factor' ( $f$ ), which is defined as

$$f = \frac{q_a + q_v}{q_c + q_v}$$

where  $q_a$  = total admittance (see Section 1.4.4);  $q_v$  and  $q_c$  have been defined in Sections 1.4.2 and 1.4.3.1.

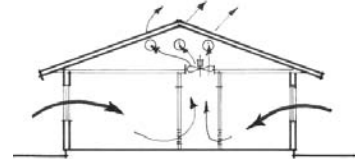
The boundaries for two or three divisions are

	sM	f		sM	f
Light	< 150 kg/m <sup>2</sup>	< 3	Light	< = 250 kg/m <sup>2</sup>	< = 4
Medium	150–400	3–5			
Heavy	>400	>5	Heavy	>250	>4

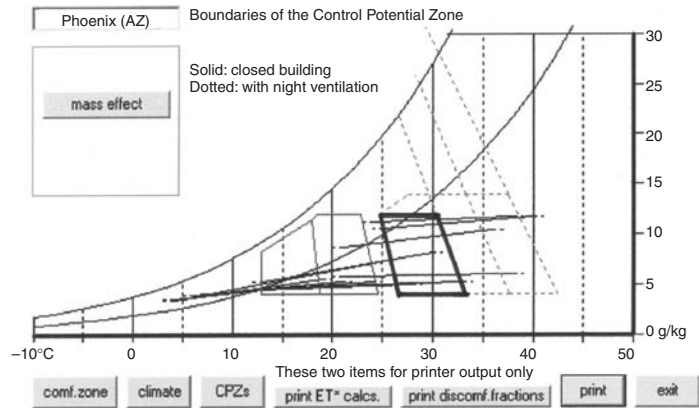
**Night ventilation** can be used to modify the mass effect, where the day's average is higher than the comfort limit, to assist the heat dissipation process. This may rely on natural ventilation through windows and other openings, but can also be assisted by a 'whole-house fan' (or attic-fan), operated when  $T_o < T_i$  (Fig. 1.65). This is a large diameter, slow moving fan, built into the ceiling around the centre of the house. The arrangement should be such that it draws air through all rooms (fresh air inlets in the rooms served) and pushes the air out through the attic, expelling the hot air of that space. This will not provide any sensible air movement, but would help in dissipating any heat stored in the building fabric.

The potential of such a mass effect (the extent of the CPZ) can be estimated by the following reasoning: in a very massive building the indoor temperature would be practically constant at about the level of the outdoor mean.

The outdoor mean can be taken as  $(T_{o,max} + T_{o,min}) \times 0.5$ . The amplitude (mean-to-maximum) would be  $(T_{o,max} - T_{o,min}) \times 0.5$



**Fig. 1.65**  
An attic fan (or 'whole house' fan).



**Fig. 1.66**  
CPZ for the mass effect and mass effect with night ventilation.

but as the building will not quite cool down to the minimum, it is taken as  $(T_{o,max} - T_{o,min}) \times 0.3$ . If the mean is to be within the comfort zone, the outdoor maximum must be less than the comfort limit plus the amplitude. So the limit of the CPZ will be the upper comfort limit + the amplitude.

#### Example 1.8

if in Cloncurry (northern inland Queensland) in the hottest month (December)  $T_{o,max} = 38.5^{\circ}\text{C}$ ,  $T_{o,min} = 24.5^{\circ}\text{C}$ ,  $T_{o,av} = 31.5^{\circ}\text{C}$ ,  $T_n = 27.4^{\circ}\text{C}$ , comfort limit =  $29.9^{\circ}\text{C}$ ; amplitude =  $(38.5 - 24.5) \times 0.3 = 4.2\text{ K}$   
Limit of the CPZ =  $29.9 + 4.2 = 34.1^{\circ}\text{C}$

If the mass effect is assisted by night ventilation, the fabric will be cooled down more effectively, the amplitude will be taken as  $(T_{o,max} - T_{o,min}) \times 0.6$ , thus amplitude =  $(38.5 - 24.5) \times 0.6 = 8.4\text{ K}$

Limit of the CPZ =  $29.9 + 8.4 = 38.3^{\circ}\text{C}$ .

All these temperatures are taken at the 50% RH curve and the corresponding SET lines are the boundaries of the CPZ. Fig. 1.66 illustrates the above example.

In a climate, where air temperatures are below comfort, solar radiation can be relied on to supplement the mass effect, to improve the indoor conditions, possibly ensuring comfort, but certainly reducing any heating requirement.

**1.5.1.3 Air movement**, i.e. a sensible air velocity (as discussed in Section 1.4.2) can be relied on to provide physiological cooling. Its apparent cooling effect can be estimated using Eq. (1.21). The critical point is to ensure an air velocity at the body surface of the occupants. This may be provided by cross-ventilation, relying on



the wind effect, or by electric fans, most often by low-power ceiling fans. A stack-effect, relying on the rise of warm air cannot be relied on for this purpose. First, it would only occur when  $T_i > T_o$ , and that  $T_i$  would be too high if  $T_o$  is too high. Second, even if it works, it may generate a significant air exchange, but not a noticeable air velocity through the occupied space.

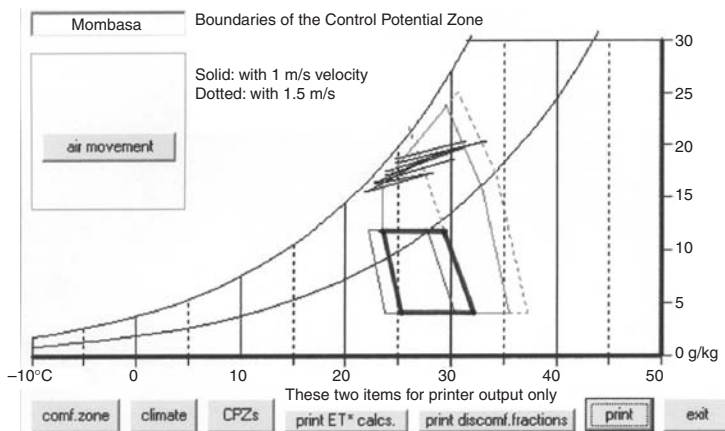
Cross ventilation demands that there should be both an inlet and an outlet opening. The difference between positive pressure on the windward side and negative pressure on the leeward side provides the driving force. The inlet opening should face within  $45^\circ$  of the wind direction dominant during the most overheated periods. To produce the maximum total airflow through a space, both inlet and outlet openings should be as large as possible. The inlet opening will define the direction of the air stream entering. To get the maximum localised air velocity, the inlet opening should be much smaller than the outlet. Positioning the inlet opening, its accessories (e.g. louvres or other shading devices) as well as the aerodynamic effects outside (before the air enters) will determine the direction of the indoor air stream.

The potential of air movement effect can be estimated as follows: The cooling effect is found using Eq. (1.21), thus it will be

$$\text{for 1 m/s air velocity: } dT = 6 \times 0.8 - 1.6 \times 0.8^2 = 3.8 \text{ K}$$

$$\text{for 1.5 m/s } dT = 6 \times 1.3 - 1.6 \times 1.3^2 = 5.1 \text{ K}$$

To define the CPZ for air movement effect these  $dT$  values are added to the upper comfort limit along the 50% RH curve. Above that the boundary will be the corresponding SET line, but below 50% there is a cooling effect even without air movement, as the air is dry, so the additional effect of the air movement is taken as only



**Fig. 1.67**  
CPZ for the cooling effect of air movement.

half of the above: the boundary line will be nearer to the vertical. These boundaries define the range of outdoor conditions under which air movement has the potential to render indoor conditions comfortable.

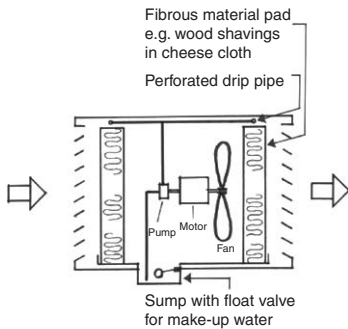
### Example 1.9

In Mombasa (lat =  $-4^\circ$ ) the warmest month is March, with  $T_{o,av} = 29^\circ\text{C}$  thus  $T_n = 17.6 + 0.31 \times 29 = 26.6^\circ\text{C}$  and upper comfort limit =  $29.1^\circ\text{C}$

Limits of the air movement CPZs will thus be

$$\text{for } 1 \text{ m/s: } 29.1 + 3.8 = 32.9^\circ\text{C}$$

$$\text{for } 1.5 \text{ m/s: } 29.1 + 5.1 = 34.2^\circ\text{C as illustrated by Fig. 1.67.}$$



**Fig. 1.68**  
Principles of a direct evaporative cooler.

**1.5.1.4 Evaporative cooling** can be provided as part of a passive system, e.g. by a roof pool or a courtyard pond, or by a spray over the roof or some other building surface. If evaporation occurs within an enclosed space, it may lower the DBT, but it increases the humidity, therefore the latent heat content, in effect it converts sensible heat to latent heat.

The total heat content of the system does not change, i.e. it is said to be *adiabatic*.

Indirectly, evaporation loss occurs if there is some evaporation within the space or room, which is adiabatic, but the moist air is then removed by ventilation. This process is referred to as 'mass transfer' and must be considered in air conditioning load calculations.

If the evaporation rate ( $er$ , in kg/h) is known, the corresponding heat loss will be

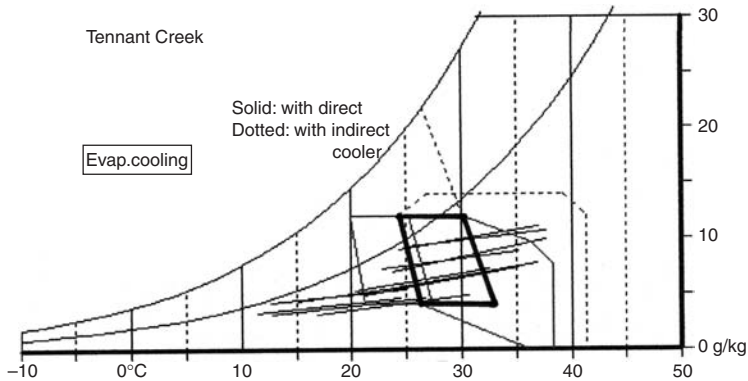
$$Q_e = (2400/3600) \times er = 666 \times er \text{ (W)}$$

where 2400 kJ/kg is the latent heat of evaporation of water.

A *direct evaporative cooler* (Fig. 1.68) would draw air in through fibrous pads, which are kept moist by a perforated pipe and feed it into the space to be cooled. In the process the latent heat of evaporation is taken from the air, so it is cooled, but the humidity (thus also the latent heat content) of the supply air is increased. The status point on the psychrometric chart will move up and to the left along a constant WBT line (see Fig. 1.12).

For this reason, the CPZ for evaporative cooling can be defined by the WBT line tangential to the upper and lower corners of the comfort zone. It is impractical to achieve more than about 11 K cooling effect (from the  $T_n$  temperature) thus the CPZ is delimited by a vertical line at the  $T_n + 11^\circ\text{C}$  temperature (Fig. 1.69).

The indirect evaporative cooler uses two fans and a plate heat exchanger (Fig. 1.70). It can still be considered as a 'passive' system, as the cooling is done by evaporation. The return air stream is



**Fig. 1.69**  
CPZ for evaporative cooling.

evaporatively cooled and passed through the heat exchanger, to cool the fresh air intake to be supplied to the space, without the addition of any moisture. The exhaust air is then discharged. A slight increase in humidity tolerance (to 14 g/kg) can be accepted if the air is cooled, hence the upper boundary of the CPZ is a horizontal line at this level, whilst the temperature limit would be at  $T_n + 14$ .

The effectiveness of this system is limited by the evaporation potential of the humid air and by the performance of the heat exchanger.

Note that in many such hot-dry locations the nights can be quite cold (see also Fig. 1.66) at least in some parts of the year and temperatures can even drop below 0°C, thus passive solar heating for winter may be combined with evaporative cooling for the summer.

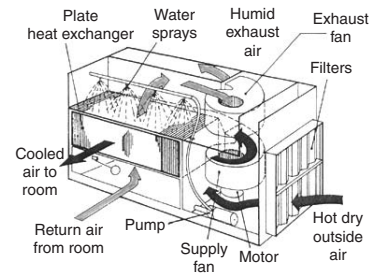
## 1.5.2 Control functions of design variables

In this section, as a summary of previous discussions, answers to two questions will be attempted:

- (1) What factors influence the magnitude of each of the components of Eq. (1.10)?
- (2) What attributes of major design variables affect the building's thermal behaviour?

### 1.5.2.1 Component heat flows

- (1) **Qi (internal heat gain)** can be influenced only in a minor way, by planning: by separating any heat emitting functions from occupied spaces, or attempting to dissipate the generated heat at or near the source. The condensing coil of a refrigerator may be placed outside, or at least ventilated separately, or the control gear of fluorescent lighting could be outside the



**Fig. 1.70**  
An indirect evaporative cooler.

- habitable space. A local exhaust could be used next to a heat-generating appliance, such as a kitchen stove.
- (2)  **$Q_s$  (solar heat gain)** on opaque surfaces is influenced not only by surface properties (reflectance), but also by the shape and orientation of the building. If it is to be reduced, the solar geometry should determine the shape: larger surfaces should face the least solar exposure. Solar heat gain through windows provides the most powerful passive control. It is affected by window size, orientation, glazing material and shading devices. Adjustable shading can provide flexibility in variable climatic situations. The sun's apparent seasonal movement can provide an automatic summer/winter adjustment. Vegetation and surrounding objects can have a strong influence on sun penetration. Deciduous plants are often used to give summer shade but allow the entry of winter sun. Whilst fenestration determines the admission of solar radiation, the thermal mass of the building affects its retention and release.
  - (3)  **$Q_c$  (conduction heat flow)** is affected by the shape of the building, by the surface-to-volume ratio and by the thermal insulating qualities of the envelope. Reflective and resistive insulation affect the magnitude of the heat flow, whilst capacitive insulation also affects the timing of heat input. In a multilayer element the sequence of resistive and capacitive layers is an important factor. More stable internal conditions are achieved if the thermal mass is located inside the resistive insulation.
  - (4)  **$Q_v$  (ventilation heat flow)** is influenced by the fenestration and other openings, their orientation with respect to the wind direction, their closing mechanisms and generally the airtightness or wind permeability of the envelope. The building shape can have a strong influence on the creation of positive and negative pressure zones, which in turn influence air entry.
 

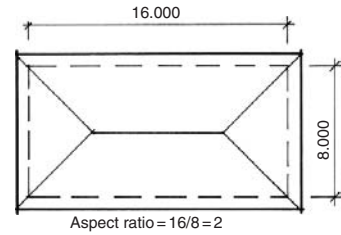
External objects, such as fences, wing walls or even vegetation can also have an effect.
  - (5)  **$Q_e$  (evaporative cooling)** is a useful technique, especially under hot-dry conditions. It can be provided by mechanical equipment, but also by purely passive systems, such as a pond or a spray. It cannot be considered in isolation: the cooled air must be retained, if it is not indoors, then e.g. by a courtyard or some other outdoor space enclosed by a solid fence. The designer must ensure that the cooling effect occurs where it is needed and that it is not counteracted by wind or solar heating.

**1.5.2.2 Design variables.** The four design variables that have the greatest influence on thermal performance are: shape, fabric,

fenestration and ventilation. These will now be briefly considered as a summary of previous discussions.

### (i) Shape

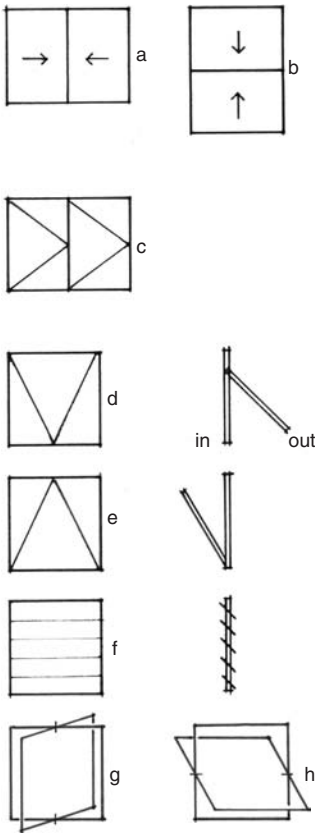
- (a) *surface-to-volume ratio*: as the heat loss or gain depends on the envelope area, particularly in severe climates, it is advisable to present the least surface area for a given volume. From this point-of-view the hemisphere is the most efficient shape, but a compact plan is always better than a broken-up and spread-out arrangement.
- (b) *orientation*: if the plan is other than a circle, orientation in relation to solar gain will have a strong effect. The term 'aspect ratio' (Fig. 1.71) is often used to denote the ratio of the longer dimension of an oblong plan to the shorter. In most instances the N & S walls should be longer than the E & W and the ratio would be around 1.3 to 2.0, depending on temperature and radiation conditions. It can be optimised in terms of solar incidence and wanted or unwanted solar heat gain or heat dissipation.



**Fig. 1.71**  
Definition of 'aspect ratio'.

### (ii) Fabric

- (a) *shading* of wall and roof surfaces can control the solar heat input. In extreme situations a 'parasol roof' can be used over the roof itself to provide shading, or a west-facing wall may be shaded to eliminate the late afternoon solar input. If the plan shape is complex, then the shading of one surface by another wing should be considered.
- (b) *surface qualities*: absorptance/reflectance will strongly influence the solar heat input; if it is to be reduced, reflective surfaces are preferred. A white and a shiny metal surface may have the same reflectance, but the white would have an emittance similar to a black body at terrestrial temperatures whilst the emittance of the shiny metal is practically negligible. Thus if heat dissipation is the aim, a white surface would be preferred.
- (c) *resistive insulation* controls the heat flow in both directions; it is particularly important in very cold climates (heated buildings) or in very hot climates (air-conditioned buildings). In non-conditioned buildings it is important for elements exposed to solar radiation. In an overheated situation any wall should either be shaded or have good resistive insulation.
- (d) *reflective insulation*: the best effect is achieved if the (double-sided) foil is suspended in the middle of a cavity, so that both the high reflectance and low emittance are utilised. This is rarely achievable. There is no difference in magnitude between the low emittance and high reflectance effects. Deterioration in time, e.g. dust deposit should be considered, hence a foil under the roof skin, face down is better than one on top of the



**Fig. 1.72**

Window types by closing mechanism

- (a) horizontal sliding
- (b) vertical sliding (double hung)
- (c) casements
- (d) top hung (friction stays)
- (e) bottom hung (hopper)
- (f) glass louvres
- (g) vertical pivot
- (h) horizontal pivot.

ceiling, face up. It affects downward heat flow more than the upward flow.

- (e) *capacitive insulation* provides a very powerful control of the timing of heat input especially in climates with a large diurnal temperature swing, as it can store the surplus heat at one time, for release at another time, when it is needed.

### (iii) Fenestration

- (a) *size, position and orientation of windows* affect sun penetration, thus solar heat input, but also affect ventilation, especially where cross ventilation (physiological cooling) is desirable.
- (b) *glass*: single, double, multiple and *glass quality*: special glasses (heat absorbing or heat reflecting glasses) may be used to ameliorate an otherwise bad situation, by reducing the solar heat input. Their qualities are constant, they would reduce solar heating even when it would be desirable and would reduce daylighting. They should be considered as a last resort.
- (c) *closing mechanism*: fixed glass, louvres, opening sashes, type of sashes used (Fig. 1.72).
- (d) *internal blinds and curtains* can slightly reduce the solar heat input, by reducing the beam (direct) radiation, but they become heated and will re-emit that heat, thus causing convective gains.
- (e) *external shading devices* are the most positive way of controlling solar heat input. The effect of such devices on wind (thus ventilation) and on daylighting and views must be kept in mind.
- (f) *insect screens* (part of fenestration) may be a necessity in hot-humid climates (with their large insect population), but their effect on air flow and on daylighting must be recognised. Air flow may be reduced by 30% even by the best, smooth nylon screen and daylighting may also be reduced by 25%. To keep the same effect, the window size may have to be increased.

### (iv) Ventilation

- (a) air-tight construction to reduce air infiltration is important both in a cold climate and in a hot climate in air-conditioned buildings,
- (b) beyond the provision of fresh air, ventilation can be relied on to dissipate unwanted heat, when  $T_o < T_i$ .
- (c) physiological cooling can be provided even when  $T_o > T_i$  and for this not the volume flow but the air velocity is important. This can only be achieved by full cross-ventilation (or mechanical means) and it may be the main determinant of not only fenestration and orientation but also of internal layout (e.g. single row of rooms).

### 1.5.3 Climatic design archetypes

**1.5.3.1 In cold climates** where the dominant problem is under-heating, where even the best building will need some active heating, the main concern is to minimise any heat loss. The surface-to-volume ratio is important and, although we cannot always build Eskimo igloos (Fig. 1.73) (which have the best surface-to-volume ratio), the idea should be kept in mind. In any case, a compact building form is desirable. Insulation of the envelope is of prime concern. U-values of less than  $0.5 \text{ W/m}^2\text{K}$  are usual in most locations in this climate. Windows should be small, at least double glazed, but preferably triple glazed, or double glazed with low-e treatment and partially evacuated with inert gas fill.

Where heating is necessary, capacitive insulation (massive construction) can be beneficial in continuously occupied buildings as it may allow intermittent heating (keeping the building reasonably warm during non-heating periods). For intermittent occupancy a lightweight, well-insulated building is preferable, as it has a shorter heating up period. Night temperatures in such a building can be very low, and if equipment protection or freezing (e.g. of water in pipes) is a risk, then a massive construction could save overnight heating.

Winter sunshine for an equator-facing vertical window, at low altitude sun angles may be significant. All other windows should be kept as small as possible. A check should be made whether a well-oriented window could be beneficial, but it is very likely that solar heating would only work if there were some form of night insulation. Any such passive solar heating would work only if there is an adequate thermal storage mass available. An externally insulated massive wall may be a good choice.

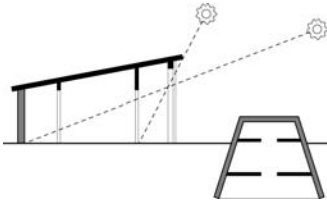
Attention should be paid to the air-tightness of the envelope, to ensure that air infiltration is not greater than about 0.5 air changes per hour. If it is very well done, and it is reduced to less than this value, ventilation should be provided to bring it up to 0.5 ach. Inadequate ventilation may lead to the accumulation of undesirable gases (formaldehydes or even radon) emitted by building materials. Entrances should be fitted with an air-lock and should be protected externally from cold winds.

**1.5.3.2 In temperate climates** the winter requirements would be similar to those mentioned above for cold climates, but may be somewhat less strict, depending on the severity of the winter. U-values in the order of 0.7 are usual in warm temperate (e.g. Mediterranean) climates, whilst in cool-temperate regions this may be down to 0.3. The building solutions would be different, to allow for the summer requirements. Any large (equator-facing) windows used for winter solar heating may cause summer overheating.



**Fig. 1.73**  
Eskimo igloos (minimum surface).

In many countries insulation is specified in terms of its R-value, rather than its reciprocal, the U-value. In cold climates R3 or R4 is not uncommon (U-values of 0.33–0.25) and ‘superinsulated houses’ have been built with up to R8 (U-values down to 0.125).



**Fig. 1.74**  
The house proposed by Socrates  
(cca 400 BC) for temperate  
climates.

Overhanging eaves or other horizontal shading devices may ensure summer shading but allow winter entry of solar radiation (Figs 1.45 and 1.74). A full cut-off at equinox would be provided with a VSA of  $90^\circ$  minus latitude, but this should be adjusted according to temperatures. For a cool-temperate climate a higher VSA would allow increased solar radiation entry, which may be welcome for the winter half-year, but not for the summer. If overheating occurs in the summer, ventilation could be relied on to dissipate the unwanted heat, as air temperatures are unlikely to be too high. No special provisions are necessary for ventilation beyond facilities for fresh air supply.

In most temperate climates the nighttime temperatures are too low even in the summer. For this reason a heavy construction (capacitive insulation) may be preferable. The time-lag of a solar heated massive wall can be set to equal the time difference between the maximum of solar input and the time when heating would be welcome.

In the UK there were practically no regulatory requirements for insulation up to 1965. Then a requirement of  $U = 1.7 \text{ W/m}^2\text{K}$  was introduced for walls and 1.42 for roofs. Since then this has been tightened several times and at present it stands at  $0.45 \text{ W/m}^2\text{K}$  ( $=R2.2$ ) for walls and  $0.25$  ( $=R4$ ) for roofs. This development is approximately in line with most EU countries. An interesting point is that many countries require insulation up to twice as good for lightweight elements than for heavyweight construction.

In the USA there are local variations, but most states follow the ASHRAE Standard 90.1, 1999, which, for residential buildings prescribes  $U = 0.412 \text{ W/m}^2\text{K}$  (R2.4) for heavy and  $U = 0.232$  (R4.3) for lightweight construction for walls, and for roofs  $U = 0.278 \text{ W/m}^2\text{K}$  (R3.6) if the insulation is on top of the roof deck, but down to  $0.099$  (R10.1) for attic roofs.

The Building Code of Australia (2003 amendment) divides the continent into 8 climatic zones and requires insulation for walls between  $R1.4 \text{ m}^2\text{K/W}$  ( $U = 0.71$ ) for the warm northern parts, through  $R1.7$  ( $U = 0.59$ ) for the southern states, up to  $R2.8$  ( $U = 0.36$ ) for the Alpine regions. For roofs the corresponding requirements are  $R2.2$  ( $U = 0.45$ ) for the north,  $R3$  ( $U = 0.33$ ) for the south and  $R4.3$  ( $U = 0.23$ ) for the Alpine regions. For northern regions the main task of roof insulation is to reduce solar heat gain.

In all cases the option is to comply with such elemental ('normative') requirements or prescriptions, or to produce energy calculations (by an authorised person or accredited software) to show that the proposed building will be as good as one complying with the elemental prescriptions. This is also discussed in Section 4.2.2.3.



**1.5.3.3 In hot-dry climates** the daytime temperatures can be very high but the diurnal range is large, often more than 20 K. Night temperatures may be too cold. Consequently, the single most important characteristic should be a large thermal mass: massive walls but also a roof with high thermal capacity. Building surfaces should be white, which would act as a selective surface. This is most important for roofs exposed to the night sky. The radiant cooling effect can help to dissipate the heat stored during the day. White paint has a high emittance, unlike a shiny metallic surface, as discussed in Section 1.1.2.3.

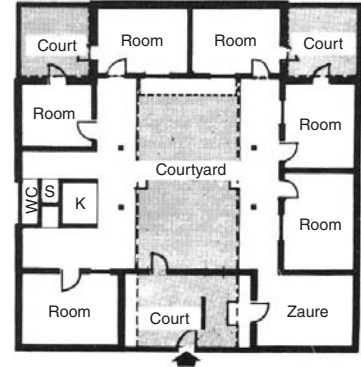
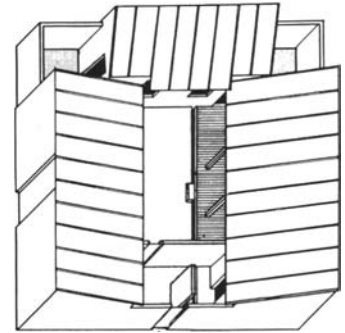
The outdoor environment is often hostile, hot and dusty, so the best solution may be an inward-looking, courtyard type building. The air mass enclosed by the building, by solid walls or fences is likely to be cooler than the environment, heavier, thus it would settle as if in a basin. This air can be evaporatively cooled by a pond or a water spray. The reservoir of cool air thus created can then be used for fresh air supply to habitable spaces. With adequate vegetation such a courtyard can become quite a pleasant outdoor living space (Fig. 1.75).

Much depends, however, on how the courtyard is treated. An unshaded courtyard, without water, can be a liability, warmer than the external environment, not only in 'winter' but also during the hottest periods. Such unwanted heating up to 5 K above the ambient has been recorded. The traditional courtyards with shading, trees and some water element can be substantially cooler than the ambient at the height of summer.

Ventilation, beyond the small fresh air supply from the courtyard is undesirable as the outdoor air is hot and dusty.

**1.5.3.4 Warm-humid climates** are the most difficult ones to design for. The temperature maxima may not be as high as in the hot-dry climates, but the diurnal variation is very small (often less than 5 K), thus the 'mass effect' cannot be fully relied on. As the humidity is high, evaporation from the skin is restricted and evaporative cooling will be neither effective, nor desirable, as it would increase the humidity. Indirect evaporative cooling may be used, as it does not add moisture to the supply air and produces some sensible cooling.

Typical of these climates is the elevated house (to 'catch the breeze' above local obstructions) of lightweight construction. The best the designer can do is to ensure that the interior does not become (much) warmer than the outside (it cannot be any cooler), which can be achieved by adequate ventilation removing any excess heat input. Warm-humid climates are located around the equator, where the sun's path is near the zenith, so the roof receives very strong irradiation. Keeping down the indoor air temperature is not enough. The ceiling temperature may be elevated due to solar heat input on the roof, thus the MRT would be increased.



**Fig. 1.75**

A modern courtyard: isometric view and plan (by Max Lock; after Saini, 1973).

When people wear light clothing, the MRT has double the effect of the DBT.

Undue increase of ceiling temperature can be prevented by

- (1) using a reflective roof surface;
- (2) having a separate ceiling, forming an attic space;
- (3) ensuring adequate ventilation of the attic space;
- (4) using a reflective surface for the underside of the roof skin;
- (5) using some resistive insulation on the ceiling.

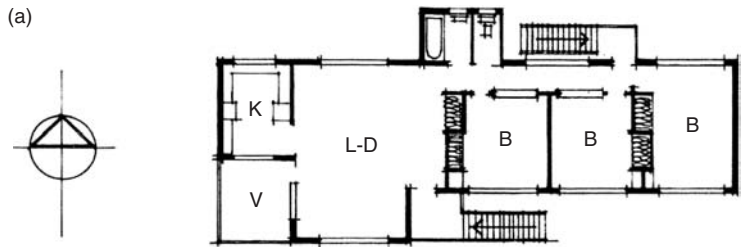
Walls facing the east and west should have no windows, to avoid heat input from a low-angle sun, and should be reflective and insulated. The sol-air temperature of these walls could be much higher than the air temperature.

Beyond the prevention (or reduction) of heat gains the only passive cooling strategy possible is the physiological cooling effect of air movement. In order to ensure maximum cross ventilation, the major openings should face within 45° of the prevailing wind direction. It should however be remembered that there are possibilities to influence the wind, but not the solar incidence. Therefore solar orientation should be dominant. North and south walls could have large openings. The rooms could be arranged in one row, to allow both inlet and outlet openings for each room. Fig. 1.76 shows such a typical tropical house.

With a north-facing wall, if the wind comes from the east or near-east a wing wall placed at the western end of a window would help creating a positive pressure zone (Fig. 1.77). At the same time, a wing wall placed at the eastern edge of a south-facing window could help creating a negative pressure zone. The difference between the positive and negative pressure would drive an adequate cross ventilation, probably better than with a normal wind incidence. It can work even if the wind direction is due east or west. A projecting wing of the building or even vegetation (e.g. a hedge) may achieve the same result.

The above discussion applies to a reasonably freestanding house. With urban developments and increasing densities in warm-humid tropical areas the ventilation effect disappears. The solution then is to use a low-power, low velocity slow moving ceiling fan, which can generate the required velocity for physiological cooling. This is a useful standby in any case, for times when there is no breeze available.

In such a dense situation (when all other houses are also elevated) the benefit of the elevated house may also disappear. A concrete slab-on-ground floor may provide a desirable heat sink. For daytime rooms (living, dining, kitchen) a heavy construction may ensure indoor temperatures close to the day's minimum. Bedrooms should cool down quickly after sunset, therefore a lightweight construction and cross ventilation would be



**Fig. 1.76**  
A typical house for warm-humid climates.

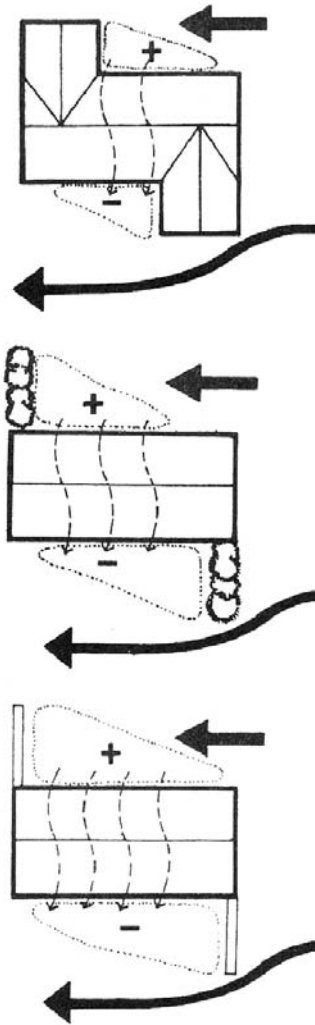
desirable. On this basis a house form of hybrid construction has been suggested to get the best of both worlds (Fig. 1.78).

**1.5.4 Condensation and moisture control**

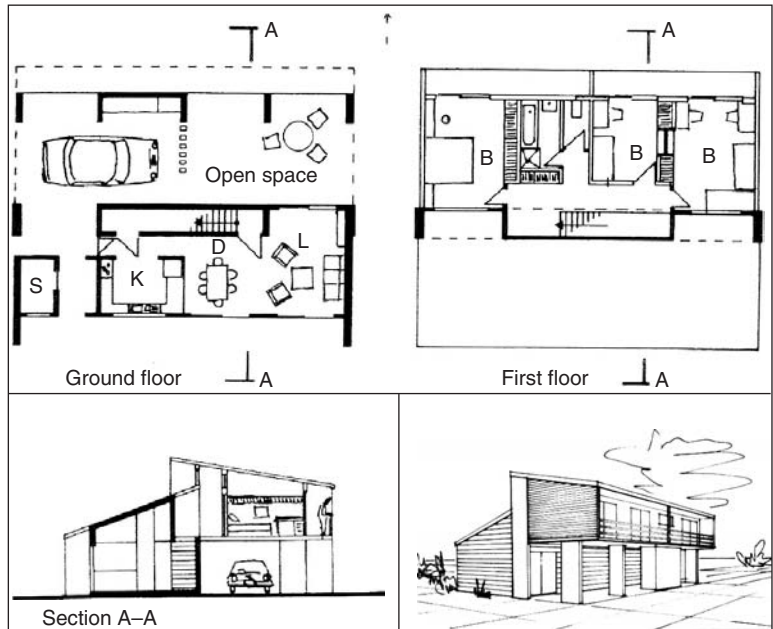
Condensation occurs whenever moist air is cooled to, or comes into contact with a surface below DPT. The process can be followed on the psychrometric chart and is best illustrated by an example.

**Example 1.10**

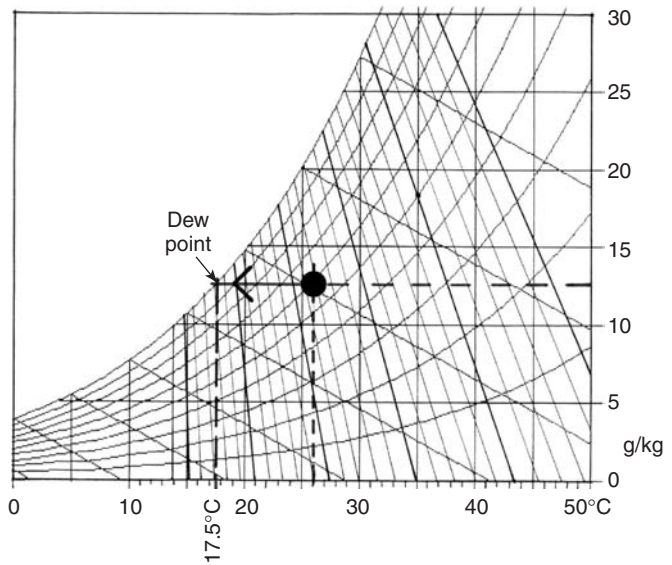
Mark the status point on the chart corresponding to (say) 26°C and 60% RH (Fig. 1.79). The absolute humidity is 12.6 g/kg and the vapour pressure is just over 2 kPa. If this horizontal line is extended to the saturation curve, the DPT is obtained as 17.5°C. This means that if this air comes into contact with a surface of 17.5°C or less, condensation will occur.



**Fig. 1.77**  
Projecting building wings, vegetation screens or wing walls can be used to generate cross-ventilation.



**Fig. 1.78**  
A hybrid house for warm-humid climates.



**Fig. 1.79**  
Part of the psychrometric chart: condensation occurs when air is cooled to its DPT.

This can often be observed on the bathroom mirror or the inside of windows in winter. Surface condensation can be allowed for, e.g. a 'condensation trough' may be included on the bottom rail of a window, which is drained to the outside. More difficult to handle and potentially damaging is the interstitial condensation, which may occur within the materials of envelope elements, especially in winter.

Vapour will permeate the envelope fabric, driven by the indoor-outdoor vapour pressure difference. The cross-section of an envelope element, such as a wall has a temperature gradient between the warm inside and the cold outside. When the vapour reaches a layer of temperature at or below the DPT, condensation will occur within the pores of the material. This liquid water may fill the pores, thus reducing the insulating qualities of the material; the fabric will become colder, which will further increase the condensation. In many cases in cold winters a roof leak was suspected, which subsequently proved to be 'only' condensation. It may lead to mould growth over such damp surfaces and may damage the construction (e.g. the plastering may fall off). In cold situations the risk is greatest at the outer edge of roof/wall junction, where the fabric is cold (due to the thermal bridge effect), especially in low-income housing, where bedrooms may not be heated at all, any vents may be sealed 'to preserve the heat', but the kitchen door is left open to allow the warm (moisture-laden) air to go up to the bedrooms.

The causes of condensation are

- (1) Moisture input, increased humidity of the room air. An average person would exhale some 50 g of water vapour in an hour. A shower may contribute 200 g and cooking or indoor drying of clothes are large producers of vapour (see data sheet D.1.7 for moisture production rates).
- (2) Lack of ventilation, which means that the vapour generated stays in the room.
- (3) Inadequate heating and poor insulation can produce very cold inside surface temperatures.

Vapour flow quantities are analogous to heat flow quantities:

Heat,	J	vapour quantity	g (usually $\mu\text{g} = 10^{-6}\text{ g}$ )
Temperature,	$T\text{ }^{\circ}\text{C}$	vapour pressure,	$p_v\text{ Pa}$
Conductivity,	$\lambda\text{ W/m.K}$	permeability,	$\delta\text{ }\mu\text{g/m.s.Pa}$
Transmittance,	$U\text{ W/m}^2\text{K}$	permeance,	$\pi\text{ }\mu\text{g/m}^2\text{.s.Pa}$
Resistance,	$R\text{ m}^2\text{K/W}$	vapour resistance	$vR\text{ MPa.s.m}^2/\text{g}^{\text{§§}}$

See Method sheet M.1.1 for the process of calculation as well as a graphic solution.

---

<sup>§§</sup> Note that in the SI the denominator is usually kept as the basic unit and the prefix is applied to the numerator, thus the reciprocal of  $\mu(\text{g/m}^2\text{ s Pa})$  is  $\text{M}(\text{Pa.s.m}^2/\text{g})$ .

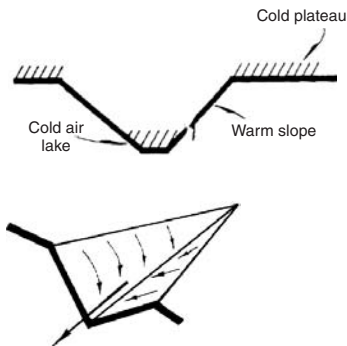
In a space with large vapour production (e.g. a place of assembly), which in winter could lead to uncontrollable condensation, a simple passive method of dehumidification is the use of a 'condenser window'. If all windows are double-glazed, install one (or several) narrow, single-glazed window, fitted with a condensation trough on the inside, which is drained to waste. As this window will be the coldest surface in the space, this is where condensation will start and if it works properly, it will precipitate much of the vapour content of the indoor atmosphere, thus reduce humidity and condensation risk elsewhere. It is clearly a simple form of passive dehumidification.

### 1.5.5 Microclimatic controls

Most published climatic data had been collected from meteorological stations, usually located on an open site, often at airports. The climate of a given site may differ from that indicated by the available data, quite significantly. On-site measurements are impractical, as nothing less than a year would suffice, and such time is rarely available for a project. The best one can do is to obtain data from the nearest meteorological station and exercise a qualitative judgement how and in what way would the site climate differ.

Local factors that will influence the site climate may be the following:

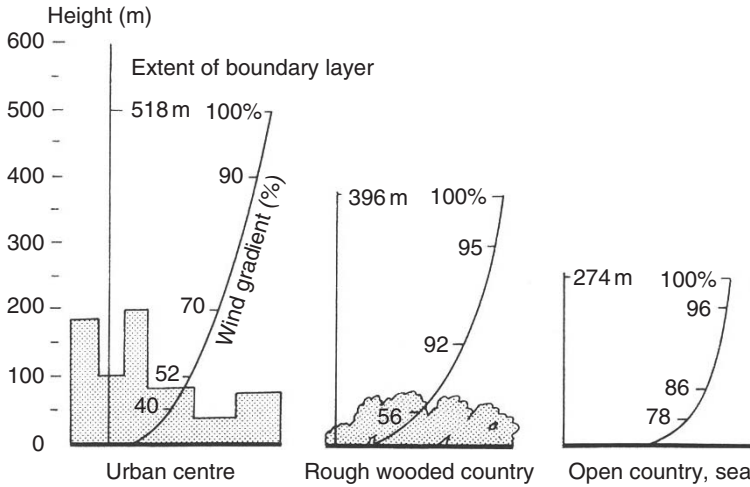
- *topography*, slope, orientation, exposure, elevation, hills or valleys at or near the site;
- *ground surface*, natural or man-made, its reflectance (often referred to as *albedo*), permeability, soil temperature, paved areas or vegetation;
- *3D objects*, such as trees, tree-belts, fences, walls and buildings as these may influence the wind, cast shadows and may subdivide the area into smaller distinguishable climate zones.



**Fig. 1.80**  
Katabatic wind: cool air flows downhill, like water.

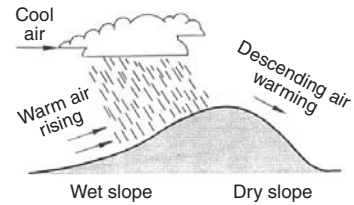
Solar radiation is affected by the clarity of the atmosphere: it will be reduced by pollution, smog and dust. Slope and orientation of such slope has an effect on irradiation. Slopes of equatorial orientation receive more and those of polar orientation receive less radiation. Hills, trees and buildings around the site also affect the apparent sunrise/sunset times, therefore the length of day, thus the daily irradiation.

Temperature during the day is likely to be higher near the ground than at higher levels. This is taken as the 'normal' layering. At night, particularly with clear skies, as the surface radiates to the sky, the near-ground temperature drops and an 'inversion' will occur. Such cooling can be more pronounced on hills and mountains; this cool air will behave as water: flow downhill, collect in a valley and constitute a *katabatic wind* (Fig. 1.80).



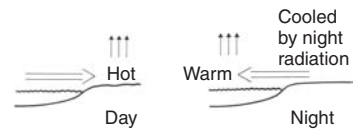
**Fig. 1.81**  
Wind velocity profiles: depth of the boundary layer.

Wind is retarded by the ground surface and turbulent flow is caused near the ground, forming a boundary layer. The depth of this boundary layer depends on the surface and on objects sitting on the surface; it can vary from about 270 m over open country to over 500 m over a city area (Fig. 1.81). All our buildings are and most of our activities take place in this boundary layer. Topography may deflect the wind, but may also affect precipitation. As Fig. 1.82 indicates, a hill deflects the flow of warm, humid air upwards; it cools and precipitation will be generated. On the leeward side of the hill the descending airflow would rarely produce any precipitation.



**Fig. 1.82**  
Rainfall on hills.

Coastal winds occur near the sea or other large bodies of water (unless they are suppressed by macroclimatic winds). During the day land surfaces heat up, causing the heated air to rise, drawing in cooler air from the water, as an on-shore wind. At night the water remains warmer than the land, causing the warm air to rise, drawing in a land breeze, an offshore wind (Fig. 1.83).



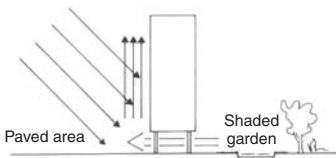
**Fig. 1.83**  
Coastal winds.

The phenomenon of urban heat islands is now well documented. The air mass over cities is likely to be warmer than in the surrounding countryside, differences (heat island intensities) up to 10 K have been measured. This effect is most pronounced when there is little or no wind, especially after sunset. It may be caused by more absorbent surfaces, radiation losses reduced by pollution, but also by energy seepage from buildings, cooling towers and vehicles, referred to as *anthropogenic* heat. A rising, upward air current is likely to produce more rain than in the nearby countryside, a process which may be assisted by the presence of urban





**Fig. 1.84**  
Urban heat island effect.



**Fig. 1.85**  
Local wind at one building.

pollution: particulate emissions that will 'seed' the humid air and start the precipitation (Fig. 1.84).

Quite strong local airflow can be caused by a single building. The equator-facing side of a large slab-type building can be strongly heated up by solar radiation, which causes an upward airflow. If the building is on *pilotis* (the ground floor is open), cooler air will be drawn in from the shaded side, reaching considerable velocities under the building (Fig. 1.85).

Recent studies show that differences can occur within a building site. Most of our calculations assume that the temperature around a house is uniform and this has now been shown to be incorrect. An air pocket between two buildings can have temperatures quite different to the air near an exposed side. Heat loss through the floor of an elevated house is assumed to flow to a  $T_o$  same as all around the building, but in fact the under-floor air temperature may be quite different.

The microclimate around a building can show substantial variation, but such variation can also be produced deliberately, and referred to as 'microclimatic controls'.

Microclimatic controls can serve two purposes:

- (1) control the conditions (sun, wind) in outdoor spaces;
- (2) assist building performance by ameliorating outdoor conditions adjacent to the building.

Microclimatic controls may affect winter and summer conditions, but they are most effective in the 'shoulder' seasons (spring, autumn) when they can significantly extend the period of purely passive operation of the building.

At the urban design scale it is useful in all streets to attempt keeping one side footpath shaded in the summer and one side sunny in the winter to allow people a choice which side to walk on. Similarly, in parks or public gardens seats should be provided in both shaded and sunny areas.

Such "controls" may be of two kinds:

- vegetation, trees, shrubs, vines and ground covers;
- built objects, fences, walls, screens, pergolas, shade structures pavements.

In a cold climate protection from cold winds may be provided by a tree-belt. The selection of plants is critical. Experts should be consulted. Deciduous trees will not offer much protection when it would be most wanted. Some trees have a tall trunk, which would allow free passage of the wind near ground level. If protection is the purpose, these should be supplemented by shrubs.

A fence or a screen, even well-positioned outbuildings can serve the same purpose.

In a hot climate the shadow cast by trees can be a great relief. The surface temperature of a roof or of other hard surfaces can reach



70°C, but in the shade it may not go above 35°C. The temperature of ground surfaces can show a similar difference, but it depends on the nature of these surfaces. Pavements will be much warmer than grass or other green ('soft') ground cover. At night pavements become much cooler than soft covers. Pavements show a large diurnal swing, black asphalt is even worse than concrete.

Another advantage of soft ground covers is that they are permeable, thus they reduce stormwater run-off and allow the ground water to be replenished.

The use of deciduous trees is recommended by many authors, to provide shade in summer but allow solar radiation to reach the building in winter. This may be so in some climates, but in many instances trees do not follow the calendar (especially in climates with a mild 'winter') and may cast too much shadow in winter and not enough in the summer.

One additional point, many architects tend to forget, is that trees grow, thus their effect will change over the years. If any trees are to be planted, landscape advice should be sought on what they would look like in 10, 20 or even more years' time. However, some cynics say that trees (and vegetation in general) are the architect's best friends: they cover up many mistakes and much ugliness.

## 1.6 Active controls: HVAC

Generally, where passive controls cannot fully ensure thermal comfort, some energy-based mechanical system can be used to supplement their performance. This may be heating, ventilation or air conditioning (HVAC). The task of such a system is usually referred to as the 'load' (heating load, air conditioning load). From the mechanical engineering viewpoint the task of the building design (i.e. of the passive controls) is to reduce such a load as far as practicable.

### 1.6.1 Heating

The design of heating systems aims to establish two quantities:

- (1) the size (capacity) of the system;
- (2) the annual (seasonal) or monthly heating requirement.

The first of these is based on a heat loss calculation under assumed design conditions, and the heating capacity will have to match that heat loss. If the building conductance ( $q$ , as in 1.4.2, Eq. (1.18)) is known, then the heat loss rate will be

$$Q = q \times \Delta T$$

**Table 1.5** Winter design outdoor temperatures for the UK

Thermal inertia	If overload capacity	Then design $T_o$
High e.g. multistorey buildings with solid floors and partitions	20%	$-1^{\circ}\text{C}$
	nil	$-4^{\circ}\text{C}$
Low, most single storey buildings	20%	$-3^{\circ}\text{C}$
	nil	$-5^{\circ}\text{C}$

where  $\Delta T = T_o - T_i$ ; ( $\text{W/K} \times \text{K} = \text{W}$ ), and  $T_o$  is taken as a value near the 'worst conditions', to make sure that the system will cope with such conditions.

Under less severe conditions the system can be operated at partial capacity.  $T_i$  is set by comfort requirements for the given building type and  $T_o$  values are given in various reference publications as *outdoor design temperatures*. This  $T_o$  is usually taken as the 10th or 20th%-ile temperature value, depending on the thermal inertia of the building.

In a lightweight, quick response building even short term very low temperatures would have a noticeable effect, thus the system sizing should be based on a lower  $T_o$ , e.g. the 10th%-ile value. A massive building can smooth over the very deep troughs; thus it is enough to use the 20th%-ile value as the  $T_o$ .

Many systems have an *overload capacity*, which could be activated under the worst conditions, so the sizing can use a higher temperature. Table 1.5 shows some typical values for the UK.

The annual (or seasonal) heating requirement can be estimated as in Section 1.3.3, Eq. (1.9).

$$\text{Htg} = q \times \text{Kh} \quad (\text{W/K} \times \text{Kh} = \text{Wh}).$$

The result will be valid for continuous heating and should be adjusted by the factors shown in Table 1.6, for duration of occupancy, building thermal mass and system response.

**1.6.1.1 Local heating.** In some instances heat can be generated in the space where it is needed. This is referred to as 'local heating'. The available energy sources and the mode of energy delivery for such local heating may be

- (1) electricity by cables;
- (2) gas piped, from grid or externally located bottle;
- (3) liquid fuel (oil, kerosene) piped from an external tank or in batch (cans, bottles);
- (4) solid fuel (coal, coke, firewood) in batch (cans, bins, baskets).

In all these (except electrical appliances) heat is produced by the combustion of some fuel. This uses oxygen, thus air supply must

**Table 1.6** Correction factors for heating requirement

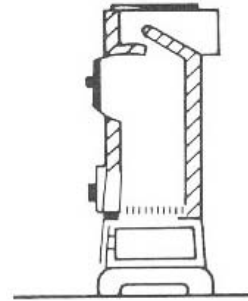
For length of working week	7 days	1	
	5 days		
	massive buildings	0.85	
For building and plant response: intermittent heating (night shut-down)	lightweight buildings	0.75	
	continuous heating	1	
		if plant response	
		quick	slow
If building mass	Light	0.55	0.70
	Medium	0.70	0.85
	Heavy	0.85	0.95
For intermittent heating only, length of heating day		if building mass	
		light	heavy
	4 h	0.68	0.96
	8 h	1	1
	12 h	1.25	1.02
	16 h	1.4	1.03

be ensured and the combustion products must be removed. This requires that they should be connected to a flue.

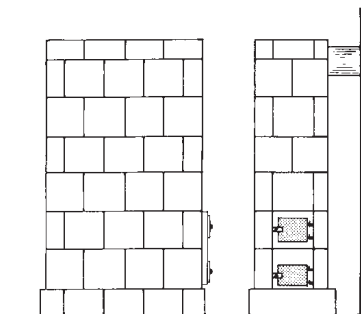
**Oil heaters** are available in small portable form. These use the room air and discharge their combustion products into the room. One point, often forgotten is that the combustion of 1 L of oil produces about 1 kg of water vapour, which increases vapour pressure in the room and thus the risk of condensation. Adequate ventilation is therefore essential.

**Solid fuel appliances** (or stoves) may be industrial products made of metal (e.g. a cast iron 'slow combustion' stove, Fig. 1.86) or may be built in situ of ceramic blocks (these have a large thermal inertia, Fig. 1.87). Both are connected to a flue. Such flues can remove a significant quantity of air and will operate well only if the room air can be replenished through appropriate vents. Open fireplaces are often used as decorative elements (many people love to look at the fire) but cannot be considered as serious heating devices because of their very low efficiency.

**Gas heaters** may have a 'balanced flue' (Fig. 1.88) where fresh air supply and the discharge of combustion products is a circuit separated from the room air. In large spaces (a church or industrial buildings) flueless gas fired radiators may be used, usually mounted overhead, in a tilted position. The burners heat a refractory plate (of shaped, perforated ceramic elements) to 800–900°C, which thus becomes incandescent and emits heat primarily by radiation. Often similar burners are fitted into existing open fireplaces.



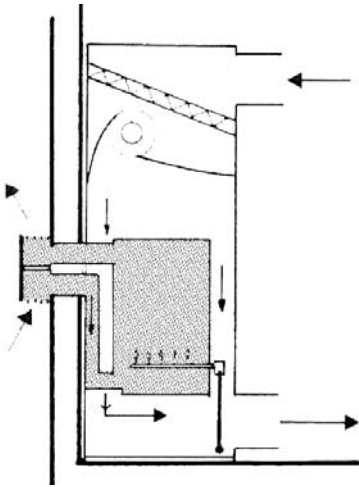
**Fig. 1.86**  
A typical cast iron stove.



**Fig. 1.87**  
A ceramic stove built in situ.

**Table 1.7** Types of electric heaters

Type	Heat emission (%)	
	Radiant	Convective
Infrared lamps	100	—
Incandescent radiators	80	20
Medium temperature (tube or panel) radiators	60	40
Low temperature panels (oil filled)	40	60
Convectors	20	80
Fan-convectors	—	100
Storage (block) heaters	10	90
Floor warming	20	80
Ceiling warming	70	30



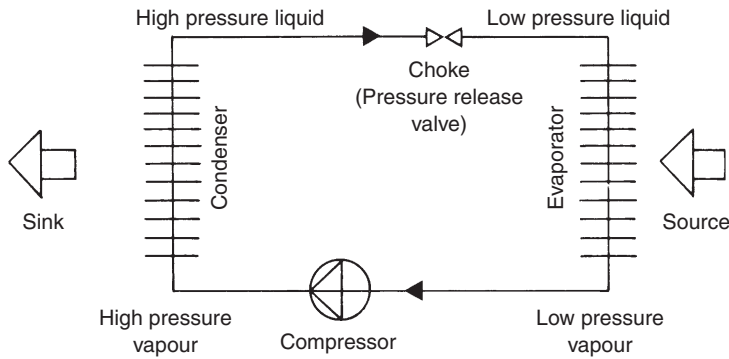
**Fig. 1.88**  
A gas heater with a balanced flue.

Organic fluorides (freons, CFCs) were largely responsible for ozone depletion in the upper atmosphere (the ozone holes) and consequent increase in UV radiation at ground level. These are now almost completely phased out, as a result of the 'Montreal protocol' of 1987, and replaced by hydrocarbons.

**Electric heaters** have the greatest variety in terms of heat output (radiant/convective) and form, although all of them are based on resistance heater elements. Table 1.7 lists the basic types of electric heaters, but a wide variety of products exists within each type. Electricity is often referred to as the most convenient 'fuel', because of its ease of transport, as it can be readily controlled ('at the flick of a switch'), as it has no combustion products at the point of heat delivery and as its efficiency at conversion to heat is practically 100%. It is rather seductive, but this view is deceptive. Its adverse characteristics are only shifted to the generating stations, with their emissions polluting the atmosphere and contributing to the greenhouse effect as well as the low efficiency of conversion from heating fuel to electricity of around 33% (on average). So 1 kWh of electricity used means the use of fuel of some 3 kWh energy content and the release of about 1 kg of CO<sub>2</sub> into the atmosphere.

A special form of electric heating is based on the *heat pump*, where the input of electricity at the rate of 1 kW can produce heating of up to 4 kW. This appears to contravene the first law of thermodynamics, but the heat is not actually produced by the heat pump. The input of 1 kW to drive the compressor facilitates the delivery of heat from a low-grade (low temperature) source, upgrading and delivering it at a useful temperature at the rate of 4 kW. Fig. 1.89 shows the principles of such a heat pump.

A working fluid or refrigerant (such as an organic fluoride or a hydrocarbon) is circulated in a closed loop by the compressor. A pressure release valve (choke) keeps the condenser side under high pressure and the evaporator side under low pressure and low temperature. When the fluid is compressed, it becomes hot and liquefies, whilst it will emit heat to the *sink*, in this case the room air. Passing through the choke it evaporates and its temperature drops, so that it can pick up heat from a *source*. This heat source may be the atmosphere (with the evaporator shaped as an air-to-liquid heat exchanger, may be warm 'grey' water discharged into



**Fig. 1.89**  
Principles of a heat pump (or cooling machine).

a sump or a natural body of water (a river or the sea), where the evaporator is shaped as a liquid-to-liquid heat exchanger.

If the purpose of using this machine is to gain heat, then the coefficient of performance is defined as

$$\text{CoP} = \frac{Q}{W} = \frac{\text{heat delivered to sink}}{\text{compressor work input}}$$

This CoP is higher for a small temperature increment (or step-up) but it reduces if the necessary step-up is large. In the ideal (Carnot) cycle the CoP is inversely proportionate to the temperature increment:

$$\text{CoP} = \frac{T'}{T' - T''}$$

where  $T'$  = sink temperature

$T''$  = source temperature (in °K)

but a real cycle will give 0.82 to 0.93 (average 0.85) of the Carnot performance. This will be further reduced by the actual component efficiencies, such as electric motor 0.95, compressor 0.8, heat exchangers 0.9.

#### Example 1.11

If there is a source of  $10^{\circ}\text{C}$  ( $= 283^{\circ}\text{K}$ ) and the heat is to be delivered at  $55^{\circ}\text{C}$  ( $= 328^{\circ}\text{K}$ )

$$\text{CoP} = 0.85 \times 0.95 \times 0.8 \times 0.9 \times \frac{328}{328 - 283} = 4.24$$

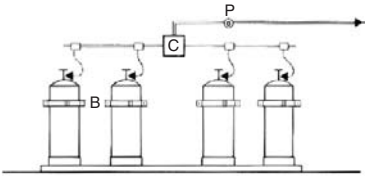
but if the source is 0°C(=273°K) and 60°C(333°K) is wanted then

$$\text{CoP} = 0.85 \times 0.95 \times 0.8 \times 0.9 \times \frac{333}{333 - 273} = 3.23.$$

If the same machine is used for cooling, i.e. to remove heat, then the definition of CoP is slightly different:

$$\text{CoP} = \frac{Q}{W} = \frac{\text{heat removed from source}}{\text{compressor work input}}.$$

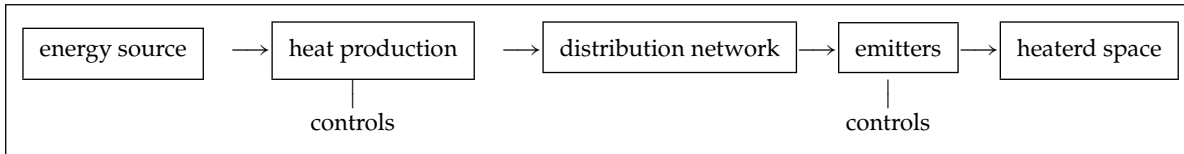
The difference is that in a heat pump application the compressor input is added to the heat gained, it is included in the value of  $Q$ , but in a cooling application it is not.



**Fig. 1.90**

Gas storage bottles  
B = buckles and straps  
C = changeover valve  
P = pressure regulator.

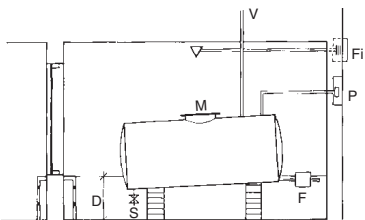
**1.6.1.2 Central heating.** Heat may be produced centrally in a building (or group of buildings), distributed to the occupied spaces by a heat transport fluid and emitted to provide the required heating. Schematically:



The energy source may be fossil fuels: coal, oil or gas, electricity, produced from fossil fuels, nuclear or hydro power, or renewable sources, such as solar-, wind-, tidal-, wave-, ocean-, thermal- or geothermal energy or biogas. At one stage coal was the most often used source, but today oil or gas is most frequently relied on. A large part of the UK and many urban areas in Australia and in America are served by a natural gas pipe network. Outside these areas gas can be supplied in bottles and fuel oil may be supplied in batches. In this case storage facilities must be provided. The transport fluid may be water or air. Heat is produced in boilers for a water system, and in a furnace for an air system.

Architectural implications are the accommodation of any fuel storage, the heat production plant and its flue, the routing and accommodation of the distribution network: pipes for a water system and ducts for an air system, as well as the choice and placement of emitters.

Figure 1.90 shows an outdoor storage arrangement for a bank of gas cylinders. Gas leaks indoors mixed with air can produce a highly explosive mixture, which can be ignited by the smallest spark. Fig. 1.91 is the section of an oil storage tank chamber. Here fire precautions are dominant: note the foam inlet valve and



**Fig. 1.91**

Oil storage tank room  
V = vent FI = foam inlet  
P = filling pipe M = manhole  
S = sludge valve F = fire shut-off  
D = depth to contain full volume.

the high threshold, which must be high enough for the chamber to contain the full tank volume of oil in case of leakage. Storage for heavier oils may have to be heated to at least the following temperatures:

- class E – 7°C
- class F – 20°C
- class G – 32°C

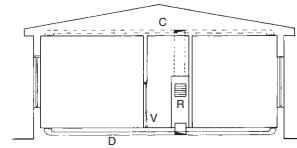
**The emitter** for a warm air system may be a grille or a diffuser (on rare occasions a directional jet). This system has the disadvantage that the room surface temperatures are below the air temperature, whereas human preference is for an MRT slightly (1–2 K) warmer than the air temperature. Fig. 1.92 shows the ducting arrangement for a domestic warm air system. The volume flow rate ( $\text{m}^3/\text{s}$ ) in a duct is  $vr = A \times v$  where  $A =$  duct cross-sectional area ( $\text{m}^2$ );  $v =$  air velocity ( $\text{m}/\text{s}$ ).

Air velocities in ducts may be 2.5–7.5 m/s for low velocity systems, but up to 25 m/s for high velocity (high pressure) systems. The latter would require smaller ducts, but would result in a much larger flow resistance, would need a greater fan power and would tend to be more noisy. In habitable rooms an outlet velocity of not more than 2.5 m/s is preferred and in no case should it exceed 4 m/s.

In modern systems, especially where summer air conditioning is necessary, the warm air central heating system is combined with air conditioning. Most often a boiler is used to produce hot water, which will feed a heating coil included in the air-handling unit.

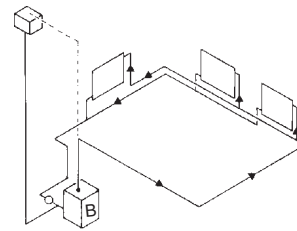
**Water-based systems** ('hydronic' in the USA) can rely on gravity (thermosiphon) circulation, or can be pumped. The former requires larger pipe sizes and is rarely (if ever) used today. For pumped systems small-bore copper pipes are normally used. For a single storey house a two-pipe ring-main system is usual (Fig. 1.93). For a house of two or more storeys two-pipe systems are the most suitable, which can be up-feed (Fig. 1.94) or down-feed (Fig. 1.95), but a one-pipe system is also possible (Fig. 1.96). In domestic systems small-bore (13–20 mm) pipes are usual, but recently the micro-bore (6 mm) system has gained popularity, where each emitter is served by a separate flow and return pipe, connected to a manifold. The design of larger systems is the task of mechanical consultants.

Emitters are most often pressed steel 'radiator' panels (at least half the emission is by convection) (Fig. 1.97), but various convector units can also be used (Fig. 1.98). Practically all forms of local heaters can also be adapted for use in central hot water heating systems, including floor warming, with embedded pipe coils (instead of electric heating cables). Floor warming is essentially a very slow response system and it is often designed to provide only



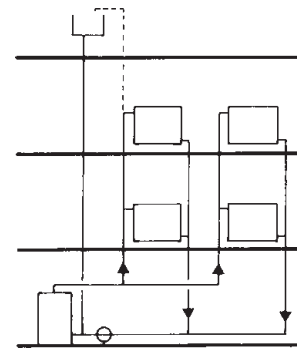
**Fig. 1.92**

A = domestic warm air system  
D = radial under-floor ducts  
C = alternative: ceiling ducts  
V = vents in doors  
R = return air grill.



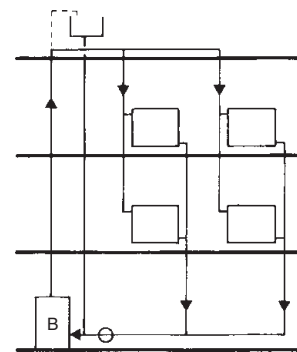
**Fig. 1.93**

Central heating ring-main system.



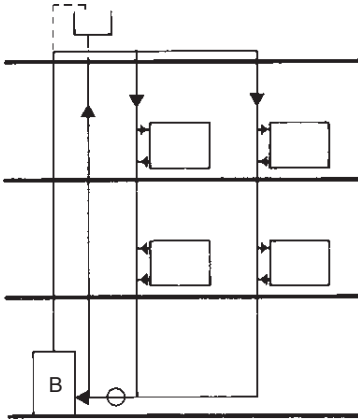
**Fig. 1.94**

A two-pipe up-feed system.

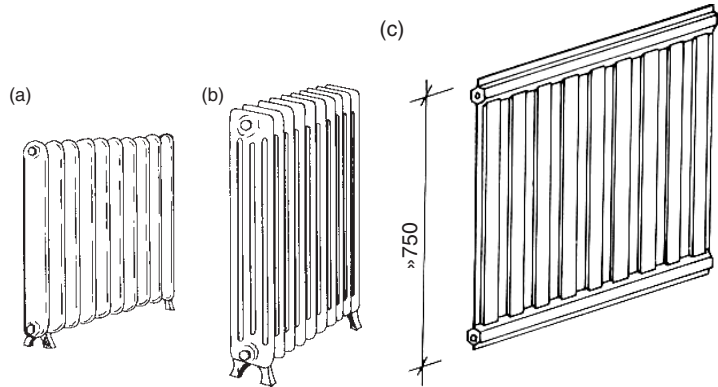


**Fig. 1.95**

A two-pipe down-feed system.



**Fig. 1.96**  
A one-pipe down-feed system.



**Fig. 1.97**  
Central heating radiator panels.

a background heating (to say  $16^{\circ}\text{C}$ ) with local, quick response heaters or emitters for topping-up heating, as required.

### 1.6.2 Hot water supply

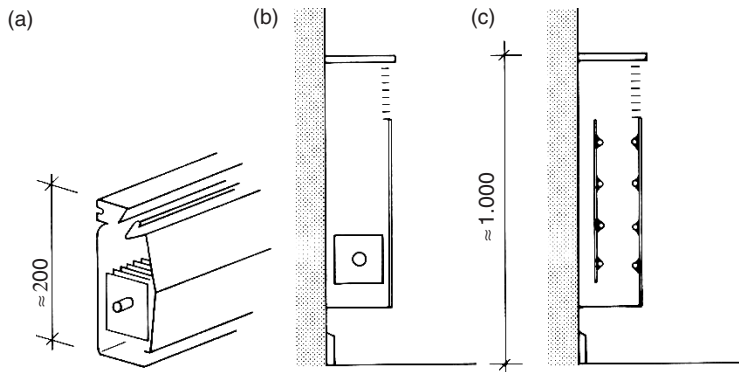
The very large range of hot water supply systems available can be categorised according to four facets:

- |                         |   |
|-------------------------|---|
| (1) by heat source:     | coupled to the space heating system<br>independent: separate boiler<br>electric<br>gas<br>solar |
| (2) by operational mode | storage type<br>semi-storage<br>instantaneous   |
| (3) by pressure:        | mains pressure<br>reduced pressure<br>low pressure<br>free outlet (inlet valve only)            |
| (4) by heat input mode: | direct<br>indirect  |

Fig. 1.99 shows the ten most popular domestic scale systems in diagrammatic terms, the following alphabetical designations of explanatory paragraphs refer to the diagrams.

- (a) *Coupled, storage type, low pressure, direct*: a branch of the central heating water circuit is led through a heat exchanger submerged in the hot water cylinder. The consumed hot water

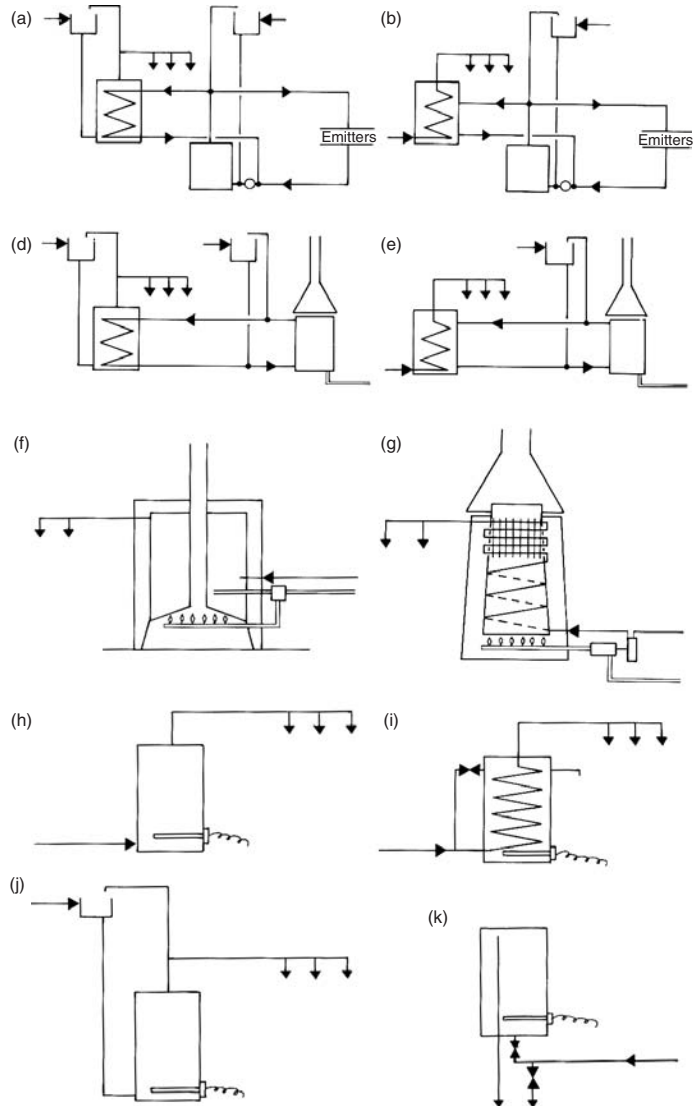




**Fig. 1.98**  
Convector units: skirting and wall mounted types.

is replaced from a header tank (cistern). Water pressure at the outlets is only that of the header tank height.

- (b) *Coupled, storage type, mains pressure, indirect*: as above, but without the header tank, fed directly off the mains; the water is heated whilst passing through the heat exchanger.
- (c) *Separate boiler, storage type, low pressure, direct*: (not shown) same as (a) above, without the emitter circuit.
- (d) *Gas, storage type, low pressure, direct*: a modest size gas heater circulates water through a heat exchanger submerged in the hot water cylinder.
- (e) *Gas, storage type, mains pressure, indirect*: same as (d), but the gas 'circulator' is connected to the tank (not the coil). The coil is fed directly off the mains; the water is heated whilst passing through the heat exchanger.
- (f) *Gas, semi-storage, reduced or low pressure, direct*: a modest size gas heater with a storage volume of 60–80 L. The burner starts as soon as there is a draw-off. When the contents are used, it can give a slow instantaneous warm flow (not hot). Full recovery will take some 20 min.
- (g) *Gas, instantaneous, free outlet, direct*: a powerful burner heats the water whilst flowing through. Water flow is controlled at the inlet. A 10–15 kW unit can serve a single draw off point. Multi-point units up to 35 kW are under mains pressure. A 30 kW unit can heat water from 10 to 65°C at a rate of 0.1 L/s. Gas ignition is controlled by a water pressure operated gas valve. Older models have a gas pilot flame, new units have electric spark ignition.
- (h) *Electric, storage type, mains pressure, direct*: both cylinder and pipework are exposed to mains pressure. If the mains connection is fitted with a pressure-reducing valve, it becomes a *reduced pressure unit* and a lighter gauge cylinder can be used.

**Fig. 1.99**

(a–k) Some hot water system diagrams (for descriptions see previous page).

- (i) *Electric, storage, mains pressure, indirect*: the tank volume heated by an immersion heater is not consumed. Mains pressure water is heated whilst flowing through the coil.
- (j) *Electric, storage, low pressure, direct*: similar to (h) but it is fed from a header tank.
- (k) *Electric, semi-storage, free outlet, direct*: a tap controls the cold water inlet, the outlet is free. Usually a small volume unit (15–50 L), with 15–20 min recovery time.

Some washing machines and dishwashers (which use electrically triggered solenoid valves) can only operate with mains pressure water. The indirect types (b, e, i) have the advantage that mains pressure is provided without the expense of a heavy cylinder. In most of the UK these systems have no relevance as the whole of the water installation must be fed from a storage cistern (mains connection allowed only for one tap in the kitchen).

Electric storage type units can be used with off-peak electricity, which is much cheaper. The distance between the water heater and draw-off points should be kept to a minimum, to avoid the 'dead-leg' water wasted (as it cools down) each time the hot tap is opened.

In larger installations a secondary hot water circulation system (flow and return) can be installed, such as that shown in Fig. 1.100 with well-insulated pipes. This would ensure instant hot water at every draw-off point. The return pipe can be quite small.

The use of solar water heaters is becoming increasingly widespread. The most successful systems use *flat plate collectors*. These consist of an absorber plate (usually copper) with attached tubes (or waterways formed by the sheet) with a selective black finish ( $\alpha_{\text{solar}} \gg \epsilon_{100}$ ) in a tray-form casing with a glass top.

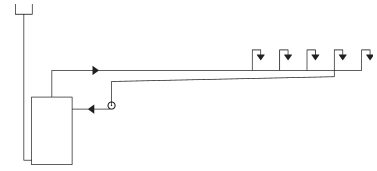
Fig. 1.101 shows some arrangements of connecting such a collector to a hot water tank and providing an auxiliary (booster) heater.

- (a) thermosiphon system (gravity-driven circulation) with an electric booster;
- (b) the same with a gas-fired 'circulator' booster;
- (c) a *close-coupled* thermosiphon system (with an integral tank) – this seems to be the most successful system, but rather expensive;
- (d) a pumped installation, where the tank is at ground floor level.

Many combinations and permutations result in a wide variety of systems, from mains-pressure units to low pressure (inexpensive) systems, fed from an elevated cistern, and solar pre-heaters connected to a conventional hot water system of some kind. It is suggested that the above system (b) is ecologically the most sound one.

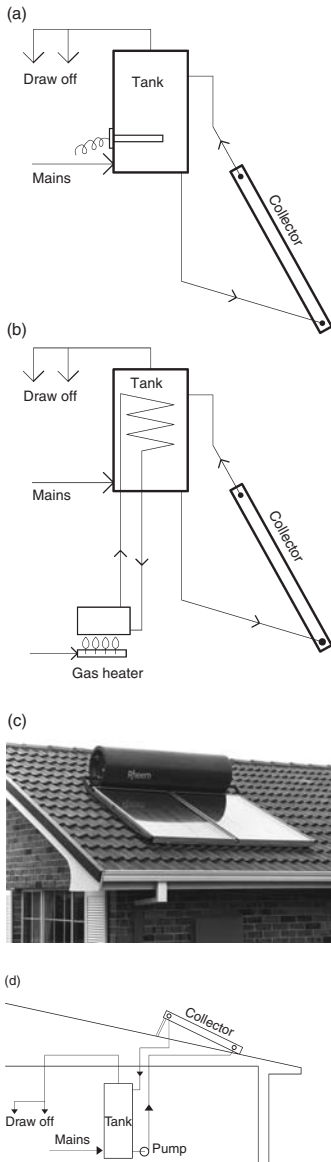
A good system in a favourable climate can provide up to 90% of a household's hot water demand, at 60–65°C (100% if the user is willing to compromise to have a less hot, say 50°C water), but 50% is quite possible even in less sunny climates.

Although a solar water heater with a gas-fired booster is the most efficient and ecologically sound (see also Section 4.1.4.2, Table 4.7), an instantaneous gas heater, such as (g) in Fig. 1.99 is very wasteful in water consumption. Opening the water tap triggers the gas burner. The cold water content of the unit runs to waste before hot water arrives at the tap. With an average load pattern 35–70 L



**Fig. 1.100**  
Secondary hot water circulation  
(for instant hot water).

water per day is wasted, compared to a waste of only 4–5 L with a storage type unit.



**Fig. 1.101**

Some simple domestic solar water heater systems, (a) thermosiphon, with electric booster, (b) same, with gas circulator, (c) with close coupled tank, (d) pumped system.

### 1.6.3 Ventilation and air conditioning

Both these systems must be capable of providing a sufficient fresh air supply to occupied spaces. If natural ventilation is relied on, the requirements can be stated in qualitative terms only, but for closed buildings served by a mechanical system fresh air requirements are set by regulations. Ventilation requirements are usually given as a function of occupancy density (in either volumetric or floor area terms) in L/(s.pers), or if no such information is available, then in terms of air changes per hour (number of times the whole volume of air must be exchanged every hour). See data sheet D.1.9 for typical ventilation requirements. These values are for general guidance only, may vary according to locally valid regulations.

**1.6.3.1 Mechanical ventilation systems** may be of three types:

- (1) extract
- (2) supply
- (3) balanced.

Extract systems are useful near a source of contamination, such as toilets, kitchen cooker hoods and laboratory fume cupboards. These create a negative pressure – relief should be provided by vent openings.

Supply systems bring in filtered outside air and create a positive pressure. Air must be released through vents. Useful where the entry of dust should be prevented. A special form of this is the fire ventilation, which forces air at high pressure (some 500 Pa) into staircases and corridors, to keep the escape route free of smoke.

Balanced systems have both supply and exhaust provided by mechanical means. These can provide a great degree of control, but are expensive. The supply flow is usually kept higher than the exhaust, to keep a slight positive pressure and thus prevent unwanted dust entry.

Fans are used to drive the air. Two main types can be distinguished:

- (1) propeller or axial flow fans; very effective when working against small back-pressure (flow resistance). The latter term is used when fitted inside a cylindrical casing.
- (2) centrifugal (or radial flow) fans: the intake is axial, the output is tangential. The impellers may have straight radial blades, forward or backward curved or aerofoil shaped blades. These can be optimised for the particular installation, with emphasis

on flow quantity, or to work against large back-pressure, or on quietness. Large fans are almost always of this type and for extensive ductworks these centrifugal fans ('blowers') must be used.

Filters can be one of four types:

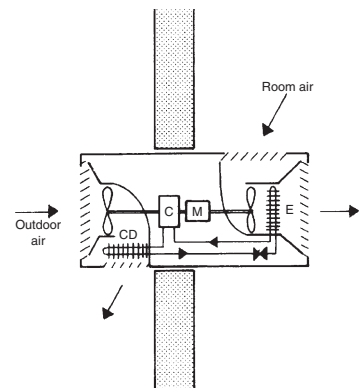
- (1) dry filters, 25–50 mm thick, usually disposable, panel or roller type, using a fabric or porous paper or other fibrous material. Some types can be cleaned by water. Dry filters tend to be more efficient than the wet ones, but usually become 'loaded' (clogged up) quicker.
- (2) wet filters; 12–100 mm thick pads, e.g. metal turnings between wire meshes, oil coated ('viscous impingement filters'). These are washable, re-usable and are effective down to  $10\ \mu\text{m}$  particle sizes;
- (3) air 'washers': fine sprays against the air intake stream, particularly useful if the air is very dry and needs humidification, but also used as a pre-cooler. These must be followed by a set of 'eliminator plates', to arrest any water droplets carried by the air stream, and drain this to a sump.
- (4) electrostatic filters, up to 12 kV static charges on metal plates. These are effective down to  $0.01\ \mu\text{m}$  particle size, and normally used with a coarser pre-filter. Normally used for particularly clean areas, such as laboratories or operating theatres.

Ducts are used to convey and distribute the air. Usually made of sheet metal of rectangular cross-section, but in recent times plastic materials are often used in circular or oval sections. For larger sizes 'builder's work' ducts may be used, formed in brick or concrete, or framed and sheeted. These may have a greater surface friction (suitable for lower flow velocities) and it is difficult to prevent air leakages.

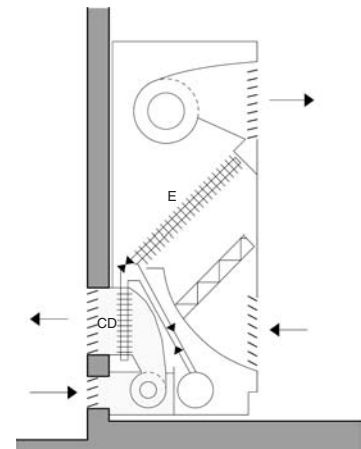
**1.6.3.2 Air conditioning systems** control the temperature and humidity as well as the purity of the air. The simplest system is the room conditioner: a packaged unit which can be installed in a window or an external wall. Its capacity may be up to 10 kW. It has a direct expansion evaporator-cooling coil (E) and a condenser (CD) cooled by the outdoor air.

Such a unit is shown in Fig. 1.102 in diagrammatic terms and Fig. 1.103 is a similar unit in console form. The split units have the cooling coil (evaporator, E) and fan inside the room, whilst the more noisy compressor (C) and condenser (CD) are included in the outdoor unit (Fig. 1.104). Some models have a reverse-cycle facility, to act as (air-source) heat pumps for heating in winter. These constitute the most effective way of using electricity for heating, even if the CoP is not more than two.

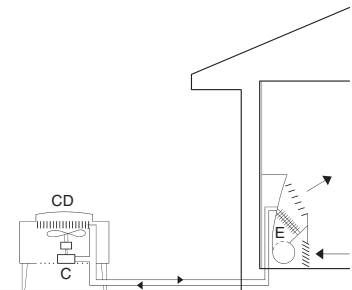
In larger systems the air is treated in an air-handling unit, which includes the fan and is distributed by a ductwork. The heating coil



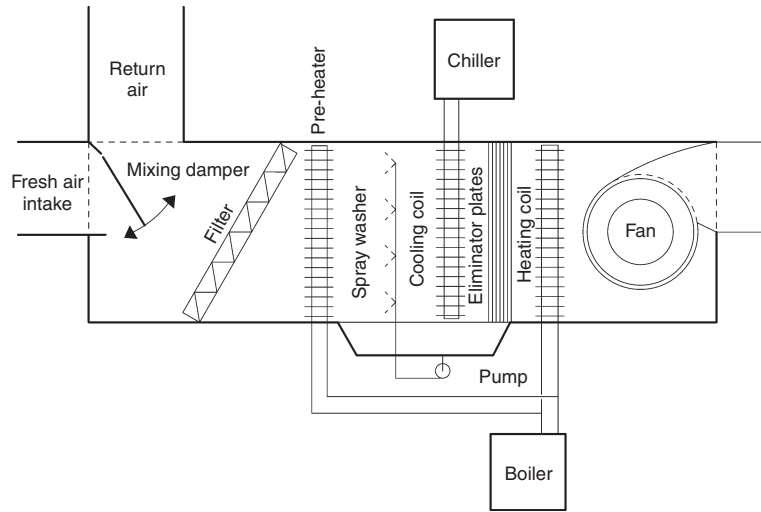
**Fig. 1.102**  
Schematic diagram of a packaged air-conditioner unit.



**Fig. 1.103**  
A console type air-conditioning unit.



**Fig. 1.104**  
An air-conditioner 'split unit'.



**Fig. 1.105**

A typical central air-handling unit (arrangement diagram).

of the air-handling unit is served by a boiler, which delivers hot water. The cooling coil can be of a direct expansion type, i.e. the evaporator of the cooling machine itself, or the cooling machine can become a chiller (the evaporator shaped as a refrigerant-to-water heat exchanger), supplying chilled water to the cooling coil.

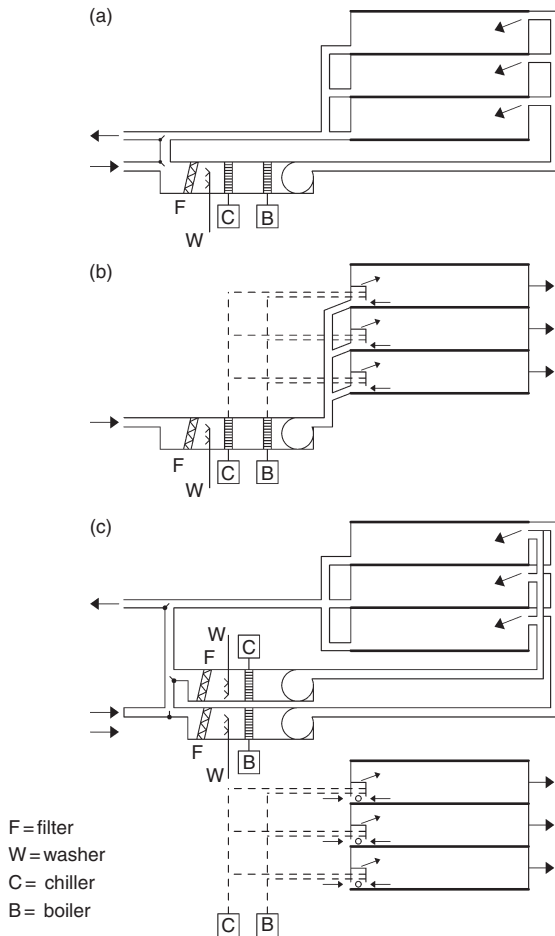
Fig. 1.105 shows a central air-handling unit and Fig. 1.106 presents the four basic system types in diagrammatic form.

In an *all-air system* (a) the plant is centralised and the treated air is distributed by a network of ducts. A rather inflexible system, using quite large ducts for both supply and return. The air volume flow rate to each room is constant and the required condition is set at the central plant. It may include a terminal re-heat facility, to provide some flexibility, but at a cost in energy.

A significant improvement is the variable air volume (VAV) system, where the supply air condition is constant and the cooling requirement of each room can be matched by reducing or increasing the air flow at the diffuser. This is the most energy efficient system.

At the other extreme is the local air-handling system (d), where each room or group of rooms would have its own fan-coil unit, supplied by chilled and hot water from a central plant. Each room may have its own controls. The decentralised air-handling is similar to the above, but a whole zone or a floor may have its air-handling unit.

In an induction system the central plant may produce over-cooled and very dry air and supply this to induction units in each room, where the supply air jet induces a flow and mixing with room air, thus creating a recirculation. Heating and cooling coils



**Fig. 1.106** Four basic air-conditioning systems: (a) an all-air system, (b) an induction system, (c) a dual duct system, (d) local air handling.

may or may not be included in these units, which may be supplied from a central chiller and boiler (b).

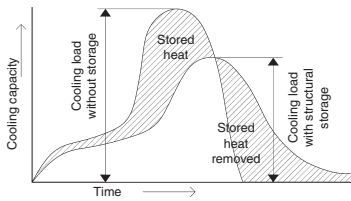
In a dual duct system there may be two central air-handling units, supplying cooled or heated air respectively, which are ducted to each room and can be mixed at the outlet to the desired condition. A very flexible but in energy terms very wasteful system (c).

These are only the basic types: a very large number of variations and permutations are available, both in terms of system arrangement and in size. In large systems the air-handling units would be room-size and may provide conditioned air supply to a number of separate zones. A building of any size could (and should) be divided into zones, according to exposure to external load, to occupancy variations and the timing of such loads.

Significant energy savings can be achieved by the control of air-conditioning systems. All systems must provide a fresh air supply, at least as much as required for ventilation purposes. However, internal loads can be removed, if the outdoor air is cooler than the indoors, with an increased outdoor air supply, without running the chiller plant. This is often referred to as an *economy cycle*.

In many instances it is advisable to provide a *night flush* of (cool) outdoor air to remove the heat stored in the building fabric and thus reduce the following day's cooling requirement. Storage of heat in the fabric of the building can also be relied on to reduce the peak-cooling requirement, as indicated by Fig. 1.107. Another possibility is to provide individual workstation controls: providing a minimum of general conditioning (e.g. in a large office) with individually controllable supplementary air supply to each workstation.

Such controls may become parts of a BEMS (building energy management system) which would coordinate all the building's energy using equipment in a responsive manner, to minimise energy use. Ultimately such systems can produce what has been referred to as *intelligent buildings*.



**Fig. 1.107**

The effect of structural storage on air-conditioning load and required plant capacity.

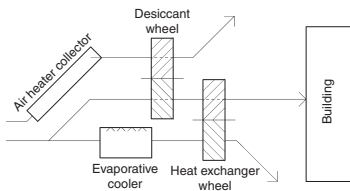
#### 1.6.4 Open cycle cooling systems

In conventional cooling machines (such as Fig. 1.89) the refrigerant (or coolant) fluid circulates in a closed loop. Its evaporation provides cooling and it is then 'reactivated' (condensed) by the action of a compressor. As opposed to this, in the open cycle systems water is the coolant, its evaporation provides cooling and it is then discharged. The whole system is open to the atmosphere.

The simplest open cycle system is the *direct evaporative cooler* (Fig. 1.68), which has been discussed in Section 1.5.1.4. It was considered as a 'passive system', although it may use a small pump and a fan, but the cooling is provided by natural evaporation. Its drawback is that it increases the humidity of the supply air (see Fig. 1.12).

This is avoided by the indirect evaporative cooler, where the exhaust air is cooled and it in turn cools the intake air through a heat exchanger, without adding moisture to the supply air. The crucial element is the plate heat exchanger, shown in Fig. 1.69.

A more sophisticated system is shown in Fig. 1.108. This uses a 'desiccant' or moisture transfer wheel, which is packed with silica gel (or some other absorbent or adsorbent) between two wire meshes. In its upper position it is dried out (reconditioned) by solar heated air. Turning slowly, this dry sorbent will come into the path of the supply air and will pick up much of its moisture content. Sorption is an exothermic process (see Fig. 1.13), thus both



**Fig. 1.108**

An open cycle cooling system using solid sorbents.



the wheel and the air become warm. It will be passed through and cooled by a rotary heat exchanger (heat transfer wheel). This, in its lower half, is cooled by the evaporatively cooled air stream, which is then discharged. Besides the supply air passage, the system has two auxiliary passages open to the atmosphere: one to remove moisture, the other to provide cooling.

Another open cycle system is shown in Fig. 1.109. This uses a liquid sorbent (such as a glycol) in aqueous solution. This is sprayed downwards in the 'desorber', against an upward moving solar heated air stream, which 'dries out' the solution, evaporating much of the water. The warm enriched solution passes through a heat exchanger and is sprayed downwards in a second column (the absorber) against an upward air stream (return air from the house, possibly mixed with fresh air) where much of its moisture content is absorbed by the rich solution (which becomes diluted and returns to the desorber). The air is then supplied to the house through an evaporative cooler.

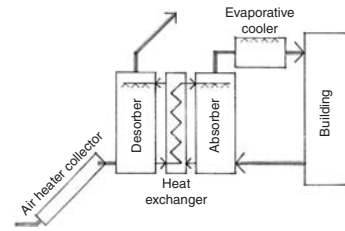
These two and several other open cycle systems have been produced and a few have reached the commercial development stage. Their electricity consumption for a given cooling capacity is only 15–20% of that of a conventional air conditioner. Unfortunately they tend to be bulky and the performance of sorbent materials tends to be reduced in time, over thousands of cycles.

### 1.6.5 Integration/discussion

HVAC services must be integrated with the architectural design in two ways:

- (1) in performance,
- (2) in hardware.

Examples of performance integration occur throughout this chapter. The last of these was in conjunction with Fig. 1.107, which showed that building mass can reduce the necessary installed capacity of the AC system. Table 1.6 and the associated discussion showed the interdependence of occupancy pattern, building mass and plant response. Table 1.7 implies that even electric heaters should be matched to occupancy pattern and building fabric. Floor warming is appropriate for continuously and uniformly occupied buildings. Convectors can be used where the air should be heated up quickly, but with heavy construction this would leave the room surfaces colder. Panel radiators are good where quick response is not required, but steady warmth is welcome. Infrared lamps and incandescent radiators are the choice where there is no chance of heating up the fabric, or the room air, but instantaneous heating effect on the body surface of people can ameliorate the situation (e.g. in a church).



**Fig. 1.109**  
An open cycle cooling system using a liquid desiccant.

The need for 'hardware' integration includes the provision of adequate space, where it is best situated, for e.g. fuel storage, plant rooms, cooling towers (or dry condensers) and last but not least the required ductwork. These are most often under the floor slab and covered by a suspended ceiling, but can also be located on top of a floor slab, with an elevated raised floor. In both cases such a service space would add to the building height.

Such ducts could be quite bulky. The volume flow rate is the product of air velocity and cross-sectional area, thus the two are inversely related. Velocities may be between 10 and 20 m/s. Higher velocities require smaller ducts (easier to accommodate) but produce greater friction and need larger fan power; they may also be noisy. Often two sets of ducts are required: for supply air and return/exhaust air. The two should never cross each other, as that would set the depth of ceiling space necessary. Ducts should also be coordinated with the structural system, e.g. to avoid crossing deep beams. Structural elements themselves may be used as ducts, e.g. hollow beams. Sometimes, e.g. when a long row of offices is served by a central corridor, the corridor could serve as the return air duct (large cross-section, low velocity) and the return air picked up by a riser duct near the lift lobby.

These are just examples, by no means treating the subject systematically, but indicating the kind of thinking required.

At the early stages of design one can get a rough idea of the necessary duct size. This is best illustrated by an example:

#### **Example 1.12**

In an office building there will be 6000 m<sup>2</sup> space per floor. D.1.9 shows that one person should be counted for every 10 m<sup>2</sup>, thus there will be 600 persons on this floor. The ventilation (fresh air) requirement is 10 L/s per person, i.e. 6000 L/s or 6 m<sup>3</sup>/s. To remove or deliver heat at least twice that flow would be required, say 12 m<sup>3</sup>/s. Assuming a medium velocity of 15 m/s, the duct cross-section required would be  $12/15 = 0.8 \text{ m}^2$ , which could be a 1 m × 0.8 m size. To minimise the ceiling space depth, an oblong shape would be used, but the ratio of the two sides should not exceed 2. Something like 1.25 m wide and 0.64 m high would be the limit. From the aerodynamic viewpoint a circular duct would be preferable (air flows in a spiral motion), as this gives the least resistance and needs the least fan power. The area of a circle is  $r^2\pi$ , which gives an  $r$  of some 0.5 m, i.e. a diameter of 1 m (!). However, in a circular duct (lesser resistance) a higher velocity may be acceptable.

There are also economic implications. It is not unusual, even with a good design that the ceiling spaces required for ductwork would add up over 10 floors to the height of an extra floor. This would

imply extra cost of structure and envelope, which will not produce any returns.

At an early stage of the design strategic decisions should be reached in consultation with the services engineer, such as where to put the plant room(-s) the outline of the distribution system, any need for major riser ducts, etc. A good start would save many problems later and avoid having a patched-up job.

# PART 2

## LIGHT: THE LUMINOUS ENVIRONMENT

<b>2.1 Physics of light</b>	<b>97</b>	<b>2.4 Design methods</b>	<b>113</b>
2.1.1 Attributes of light	97	2.4.1 Total flux method	114
2.1.1.1 The colour of light	97	2.4.1.1 Daylight design diagrams	115
2.1.2 Surface colours	99	2.4.2 Daylight factor	115
2.1.3 Photometry	100	2.4.2.1 The pepper-pot diagram	119
2.1.4 Transmission of light	102	2.4.3 Models	120
<b>2.2 Vision</b>	<b>104</b>	2.4.4 Control of sunlight	123
2.2.1 The eye and brain	104	2.4.4.1 Beam sunlighting	124
2.2.2 Visual performance	105	<b>2.5 Electric lighting</b>	<b>126</b>
2.2.3 Lighting requirements	106	2.5.1 Lamps	127
2.2.4 Glare	107	2.5.2 Luminaires	130
<b>2.3 Daylight and sunlight</b>	<b>108</b>	2.5.3 Local lighting design	133
2.3.1 Sky conditions	108	2.5.4 The lumen method	134
2.3.2 Daylight illuminance	110	2.5.5 Glare in artificially lit interiors	137
2.3.3 Luminance distribution	111	2.5.6 Integration / discussion	140
2.3.4 Overshadowing	112		

## Symbols and Abbreviations

a	acuity (visual)	CT	colour temperature
c	velocity of light ( $3 \times 10^8$ m/s)	DF	daylight factor
cd	candela (source intensity)	DFD	downward flux fraction
d	distance	DLOR	downward light output ratio
f	frequency	E	illuminance (éclairage), lux
g	glare constant	ERC	externally reflected component (of DF)
lm	lumen (light flux)	FFR	flux fraction ratio
lx	lux (illuminance)	G	glass factor
$\alpha$	absorptance	GI	glare index
$\beta$	angle of incidence	$H_m$	mounting height
$\gamma$	altitude angle on sky	I	intensity (of light source), cd
$\eta$	efficiency	INC	angle of incidence
$\theta$	viewing (source-) angle	IRC	internally reflected component (of DF)
$\lambda$	wavelength	L	luminance ( $\text{cd}/\text{m}^2$ )
$\rho$	reflectance	LED	light emitting diode
$\sigma$	visual angle	LOR	light output ratio
$\tau$	transmittance	M	maintenance factor (glass cleaning)
$\phi$	phase delay angle	MF	maintenance factor (lumen method)
$\Phi$	light flux (lm)	PSALI	permanent supplementary artificial lighting of the interior
$\omega$	solid angle	RI	room index
A	area	SC	sky component (of DF)
ALT	solar altitude angle	UF	utilisation factor
B	bars (framing) factor	UFF	upward flux fraction
C	contrast	ULOR	upward light output ratio
CCT	correlated colour temperature	V	value (Munsell-)
CIE	Commission International d'Éclairage		
CRI	colour rendering index		

## 2.1 Physics of light

A narrow wavelength band of electromagnetic radiation (from about 380 to 780 nm, as shown in Fig. 1.2) is perceived by our eyes as light.

### 2.1.1 Attributes of light

As for any other electromagnetic radiation, the velocity of light ( $c$ ) is approximately  $3 \times 10^8$  m/s (or 300 000 km/s). Its two main attributes are its quantity and its quality. Its quantitative aspects are discussed in Section 2.1.3 (photometry). Its quality is characterised by wavelength ( $\lambda$ , in m) and its reciprocal, the frequency ( $f$ , in Hz). The product of these two always gives the velocity:

$$c = f \times \lambda, \quad (2.1)$$

so, if one is known, the other can be found by dividing the known one into the velocity

$$\lambda = \frac{3 \times 10^8}{f} \quad \text{or} \quad f = \frac{3 \times 10^8}{\lambda}.$$

**2.1.1.1 The colour of light** is determined by its spectrum or spectral composition. Light of a particular wavelength, or a narrow band of wavelengths is referred to as *monochromatic*. The colour of broad-band light depends on the relative magnitude of its components, on its spectral composition. A continuous spectrum white light can be split by a prism into its components, which are perceived as colours, as shown in Table 2.1.

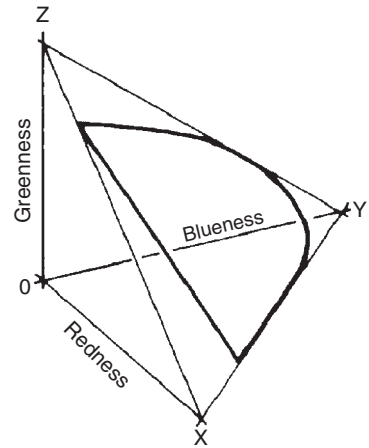
The three-colour theory of light distinguishes red, green and blue as the primary colours, and any colour can be defined in

**Table 2.1** Colour of light

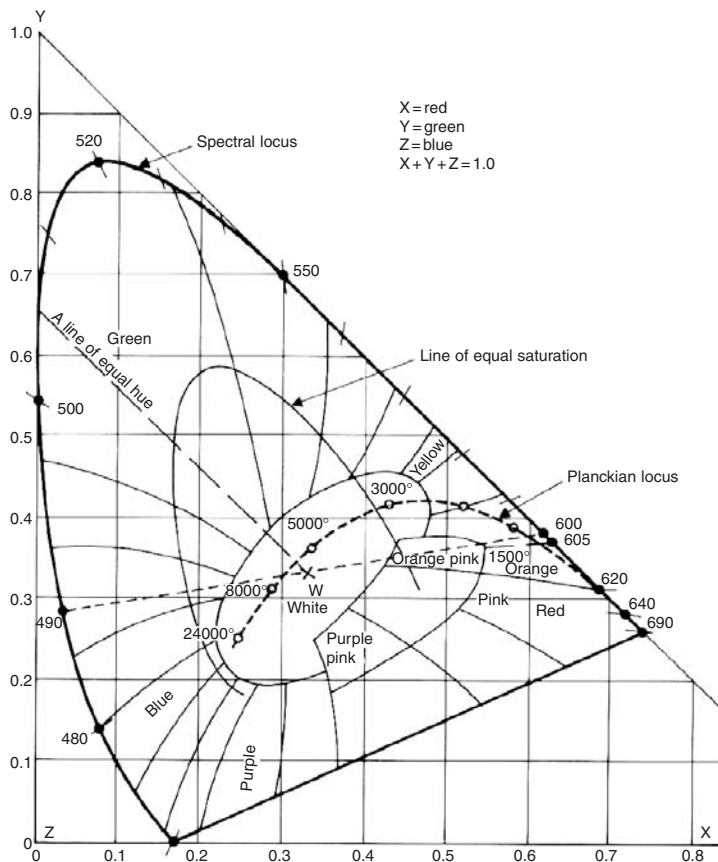
Colour	Wavelength band (nm)
Red	780–630
Orange	630–600
Yellow	600–570
Green/yellow	570–550
Green	550–520
Blue/green	520–500
Blue	500–450
Violet	450–380

terms of its redness, greenness and blueness. If these are decimal fractions, the three must add up to 1. A 3-D coordinate system can be set up to represent the three components, with the three axes being red, green and blue (Fig. 2.1). It can be represented in 2-D form, the red (X) and green (Y) axes drawn and the blue implied, as  $Z = 1 - (X + Y)$ . This diagram is referred to as the CIE\* chromaticity chart (Fig. 2.2).

This is a very clever device: the outer parabola-like curve is the locus of spectral (pure) colours, from red to violet, in an anticlockwise direction (with wavelengths in nanometres indicated). The straight line connecting the two ends of this curve indicates non-spectral colours (mixtures) magentas, from pink to purple. The centre of the diagram is the 'white point', where the



**Fig. 2.1**  
Framework of the CIE chromaticity chart.



**Fig. 2.2**  
The CIE chromaticity chart.

\* Commission International d'Éclairage = International Lighting Commission.

light would contain equal amounts (1/3) of all three components. A straight-edge laid across the W-point will indicate (at opposite sides of the spectral locus) a pair of spectral colours which would add up to white (e.g. a 600 nm yellow-orange mixed with a 490 nm blue-green would be perceived as white light). These pairs are referred to as complementary colours.

The spectral locus indicates colours of full saturation and the radius from the W-point gives a scale of saturation. 'Equal saturation' contours can be interpolated between the W-point and the spectral locus. One such line of equal saturation is shown in Fig. 2.2. The oval-shaped area around the W-point indicates colours perceived as 'white' but with a slight tinge of the adjacent colours.

A heated body emits radiation, the wavelength composition of which depends on the body's temperature. Up to about 1500°K, the wavelengths are longer than the visible band, i.e. infrared radiation, perceived as radiant heat. Beyond this it becomes visible and its colour is a function of the body's temperature; thus, the colour can be defined by this *colour temperature* (CT). The heavy dashed line of Fig. 2.2 is the Planckian locus (named after the physicist Max Planck), indicating the CTs of black body emissions, from about 1500°K (orange) through the 3000°K (yellow-white) of a low wattage incandescent lamp, and the 6000°K solar emission, up to 24 000°K of a blue sky. (Note that CT is the inverse of the everyday colour designation, e.g. the 1200°K red would be referred to as a 'warm' colour, and the 24 000°K blue as a 'cool' colour.)

Colours other than those of the Planckian locus can be referred to by their *correlated colour temperature* (CCT), i.e. where the radial direction of the colour from the W-point intersects the Planckian locus, e.g. the line of Fig. 2.2 marked as the 'line of equal hue' (green) intersects the Planckian locus at about 6000°K, which will be its CCT designation.

The colour of light depends on the source (the spectral composition of the emission), but can also be produced by filters. A filter may reflect or absorb most of the given wavelengths and transmit only a specified narrow wavelength band. E.g. a red filter would admit only a narrow band around 690 nm, absorbing or reflecting all other components. As filtering is a subtractive process, if the incoming light had no red component, no light will be transmitted. A yellow filter may be one that admits red and green (but not blue or violet), which will be perceived as yellow.

### 2.1.2 Surface colours

Whilst coloured light from various sources would be additive (e.g. the above-mentioned blue-green and yellow-orange, or any other



pair of complementary colours, would add up to white), surface colours are subtractive, or rather their absorptances are additive. A surface painted red appears to be this colour, as it absorbs everything else, reflects only the red component of the incident light. If a red surface is illuminated by white light, which is the addition of the above yellow-orange and blue-green, it will appear to be a dirty grey, as the light has no red component, no red will be reflected. The lighting would need to be of a continuous spectrum white to reveal all colours, including the red in order to produce good *colour rendering*.

The most comprehensive classification of surface colours is the *Munsell system*. This distinguishes three attributes (Fig. 2.3):

1. **Hue**: the concept of colour, using the common terms, red, yellow, blue, etc., with transitional colours (e.g. green/yellow) and further numbered subdivisions.
2. **Value (V)** or lightness: the subjective measure of reflectance, light or dark appearance, measured on a scale of 0 (absolute black) to 10 (the perfect white). In practice, values from 1 to 9 are encountered. It can be converted into reflectance:

$$\rho = \frac{V \times (V - 1)}{100}. \quad (2.2)$$

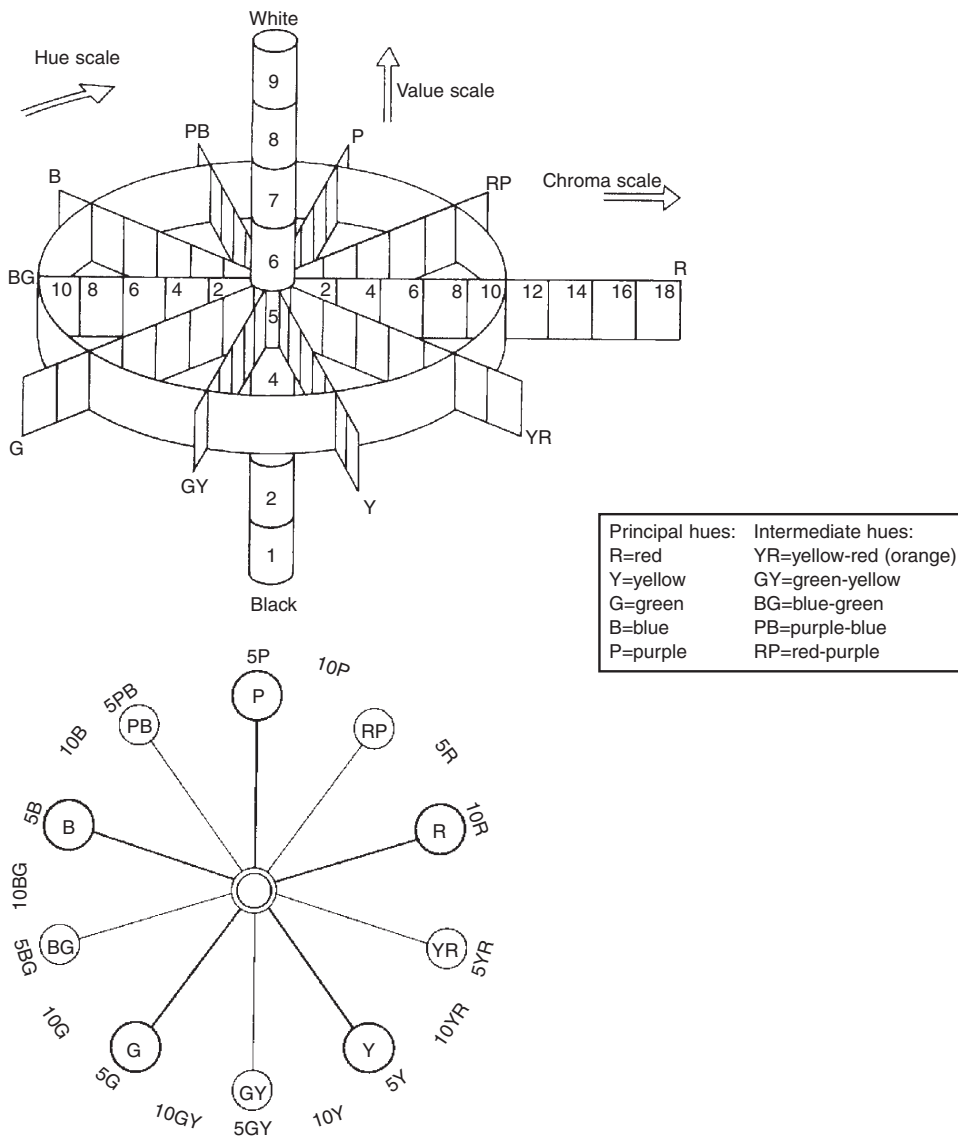
3. **Chroma** or saturation: the fullness or intensity of colour. All colours have at least 10 classes (e.g. blue-green), but some colours can be very 'strong', having a chroma up to 18.

Any colour can be designated by the three facets, *hue-value/chroma*, e.g. **5R – 4/10** = a hue of red 5 – value of 4/chroma of 10. The Munsell 'colour wheel' (Fig. 2.3) shows the framework of two (irregular) cones (joined at their bases), where the radial direction is the hue (as shown by the 'plan' view of the base circle), the vertical scale gives the value and the radial distance from the axis indicates the chroma or intensity. The vertical axis itself would contain the neutral colours, from black, through shades of grey to brilliant white. Better catalogues of paints would give the Munsell designation as well as the more 'poetic' (or gimmicky) colour names.

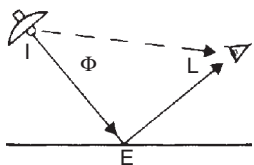
### 2.1.3 Photometry

The simplest luminous system consists of a light source (a lamp), a surface illuminated and an eye perceiving the light, both from the source and reflected by the surface (Fig. 2.4). The four measurable photometric quantities are:

1. **I**, the **luminous intensity** of a source, measured in units of *candela* (cd), which is the international standard candle, is defined



**Fig. 2.3**  
The Munsell colour wheel and its 'plan' view.



**Fig. 2.4**  
A simple luminous system: a light source, a lit surface and an eye.

as the intensity of a black body of  $1/60 \text{ cm}^2$ , when heated to the melting point temperature of platinum. It is the basic unit, from which all other units are derived.

2.  $\Phi$  (phi), the **luminous flux** (or flow of light), is measured by the unit *lumen* (lm), which is defined as the flux emitted within 1 steradian (sr) by a point source of  $I = 1 \text{ cd}$ , emitting light uniformly in all directions (Fig. 2.5). Therefore, 1 cd emits a total of  $4\pi$  lumens.

3. **E**, or **illuminance** (the symbol E comes from the French *Éclairage*) is a measure of the illumination of a surface (note that **illumination** is the process, **illuminance** is the product). The unit is *lux* (lx), which is the illuminance caused by 1 lm incident of 1 m<sup>2</sup> area (i.e. the incident flux density of 1 lm/m<sup>2</sup>).
4. **L**, or **luminance**, is a measure of brightness of a surface, when looked at from a given direction. Its unit is cd/m<sup>2</sup> (sometimes referred to as *nit*, rarely used in English), which is unit intensity of a source of unit area (source intensity divided by its apparent area viewed from the nominated direction).

A 1 cd point source enclosed in a 1 m radius spherical diffuser, has a projected area of π m<sup>2</sup>, therefore, its luminance will be 1/π cd/m<sup>2</sup>

For illuminated surfaces, the non-SI metric unit is generally used, the *apostilb* (asb). This is the luminance of a fully reflective (ρ = 1) diffusing surface which has an illuminance of 1 lx. Thus, asb = ρ × E. Both units measure the same quantity, but asb is a smaller unit: 1 cd/m<sup>2</sup> = π asb.

Luminous flux (lm) is of the same physical dimension as watt (W) and illuminance (lx) is the same as irradiance (W/m<sup>2</sup>). While the latter is an energy-based (power density) unit, the former is a luminous quantity.

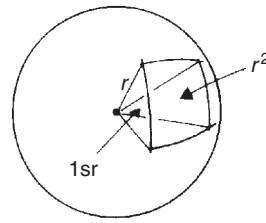
Energy quantities are not directly convertible into photometric quantities without specifying the wavelength, as the human eye's sensitivity varies with the wavelength of light. It is most sensitive to a yellow light of 555 nm, but its sensitivity (or efficacy, η) reduces in both directions, as shown by the CIE luminous efficacy curve (Fig. 2.6) This indicates the weighting of any narrow band of radiant power (in W) into light flux (lm).

Table 2.2 gives some typical values of flux output of light sources, illuminances and the luminance of some sources and surfaces.

### 2.1.4 Transmission of light

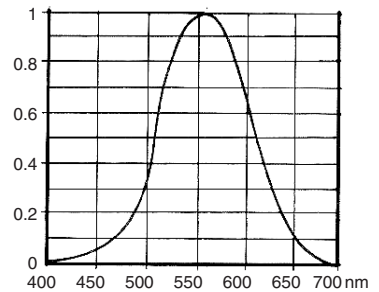
In vacuum or in a transparent homogeneous medium (air), light travels in a straight line. The *inverse square law* states that illuminance reduces in proportion to the square of the distance from the source. Fig. 2.7 shows that the flux, which at a given distance, goes through a unit area, at double that distance, will go through four times that area. So the flux density (= illuminance) reduces to one quarter.

A 1 cd source emits 1 lm within a steradian and produces an illuminance of 1 lx at 1 m distance. Thus, numerically E = I. Therefore, at a distance d



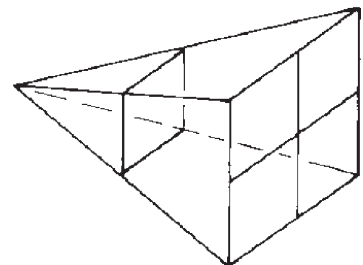
**Fig. 2.5**

The steradian. As the unit of 2-D angle is the *radian*, where the length of the arc is the same as the radius (a full circle is 2π radians), the *steradian* (stereo-radian), sr is the unit of (3-D) solid angle, that is subtended by an r<sup>2</sup> area of the surface of a sphere of radius r. As the surface area of a sphere is 4π r<sup>2</sup>, the centre of a sphere contains 4π steradians.



**Fig. 2.6**

The CIE luminous efficacy curve: spectral sensitivity of the human eye: η vs λ.



**Fig. 2.7**

Interpretation of the inverse square law.

$$E = \frac{I}{d^2} \tag{2.3}$$

The *cosine law* relates illuminance of a surface ( $E$ ) to the illuminance normal to the direction of the light beam ( $E_n$ ), which depends on the angle of incidence. If the angle of incidence is  $\beta$  (Fig. 2.8), and the surface area normal to the beam is  $A_n$ , then  $A > A_n$  and therefore,  $E < E_n$

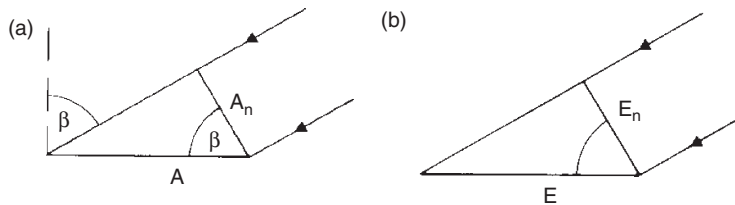
$$A = \frac{A_n}{\cos \beta} \quad \text{and} \quad E = E_n \times \cos \beta.$$

**Table 2.2** Some typical photometric values

Total flux output of some sources	lm	Typical illuminances	lux
Bicycle lamp	10	Bright sunny day, outdoors	80 000
40 W incandescent lamp	325	Overcast day, outdoors	5 000
40 W fluorescent lamp	2 800	Moderately lit desk	300
140 W sodium lamp	13 000	Average general room lighting	100
400 W mercury lamp	20 000	Full moonlit night, outdoors	0.1

Typical luminance values	cd/m <sup>2</sup>
Sun (1650 Mcd/m <sup>2</sup> )	1 650 000 000
Filament in clear incandescent lamp	7 000 000
Fluorescent lamp (tube surface)	8 000
Full moon	2 500
Paper with 400 lx illuminance:	
white ( $\rho = 0.8$ )	$\approx 100(400 \times 0.8 = 320 \text{ asb})$
grey ( $\rho = 0.4$ )	$\approx 50(400 \times 0.4 = 160 \text{ asb})$
black ( $\rho = 0.04$ )	$\approx 5(400 \times 0.04 = 16 \text{ asb})$



**Fig. 2.8**

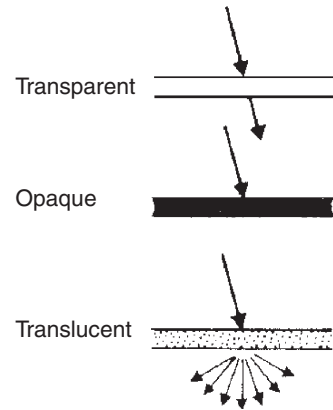
The inverse square law. A given beam of light on (a) area  $A_n$  (normal incidence) is spread over a larger area ( $A$ ) at oblique incidence, hence (b) illuminance  $E < E_n$ .

Material bodies exposed to light behave in various ways. A sheet of glass is said to be *transparent* while a sheet of plywood is *opaque*. A sheet of 'opal' perspex is *translucent* (Fig. 2.9).

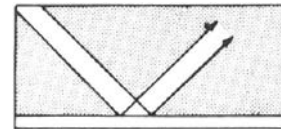
Light incident on the surface can be distributed three ways: reflected, absorbed or transmitted. The corresponding properties are reflectance ( $\rho$ ), absorptance ( $\alpha$ ) and transmittance ( $\tau$ ) and in all cases  $\rho + \alpha + \tau = 1$  (as discussed in Sections 1.1.2.3 and 1.4.1.3 in relation to solar radiation). All three terms are functions of radiation wavelength, and when applied to the visible wavelengths (light) they may be referred to as 'optical', e.g. optical transmittance or optical absorptance.

Materials, which in a small thickness appear to be transparent, may become opaque in a large thickness. The term *absorptivity* is a property of the material, indicating the absorption per unit thickness, whilst *absorptance* is the property of a body of given thickness or a surface of an opaque body.

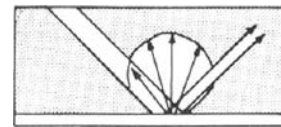
Surfaces may be classified, in terms of their reflective properties (Fig. 2.10), as *specular* (a mirror), or *diffuse* (ordinary building surfaces), or transitional: giving a *spread* reflection (basically diffuse, but with some specular component) or *semi-diffuse* (all diffuse, but with some directional bias).



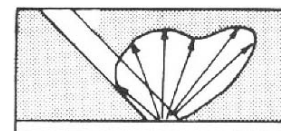
**Fig. 2.9**  
Transmission of light.



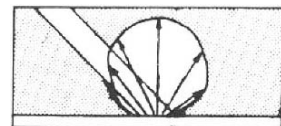
(a) Specular



(b) Spread



(c) Semi-diffuse



(d) Diffuse

**Fig. 2.10**  
Reflective surfaces.

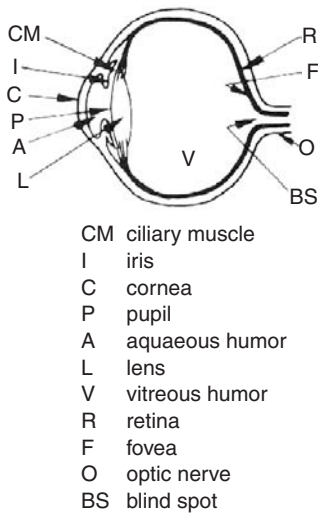
## 2.2 Vision

### 2.2.1 The eye and brain

Light is perceived by the eye. Its diagrammatic section (Fig. 2.11) can be compared to a camera:

- Aperture, controlled by a light-meter: the pupil, the size of which is varied by the iris (and controlled by the retina) is the eye's main *adaptation* mechanism.
- Focusing, controlled by a coupled range-finder: changing the shape of the lens by the ciliary muscles, thus varying its focal length, which is the *accommodation* mechanism.
- The adaptability of the retina can only be likened to using films of different 'speed' or ISO rating.

The retina incorporates two kinds of nerve endings: cones and rods. A normal eye has some 6.5 million *cones* (in and around the *fovea*), which are sensitive to both quantity and quality (colour) of light, but operate only in good lighting (*photopic vision*). The retina also has some 125 million *rods*, which are more sensitive than the cones, and which perceive only quantity of light, but do not distinguish colour (*scotopic vision*).



**Fig. 2.11**  
Section of the human eye.

The pupil's response is practically instantaneous. A second adaptation mechanism of the eye is the variation of the retina's sensitivity by varying the photochemical compounds present (e.g. of the *visual purple*). Whilst the pupil's response to changed lighting conditions is almost instantaneous, adaptation of the retina to dark conditions may take up to 30 min, as more visual purple is produced. Adaptation to brighter light is no more than about 3 min, as the visual purple is being removed.

Both adaptation mechanisms respond to the average luminance of the field of vision. Starting from darkness:

- at 0.001 cd/m<sup>2</sup> pupil is wide open and rods start to operate
- at about 3 cd/m<sup>2</sup> cones start to operate
- at 1000 cd/m<sup>2</sup> the pupil closes to its minimum

Without light there is no vision, but visual perception depends as much on the brain as on the eye. It is largely dependent on recognition. Life is continuous learning (quickest at the cradle and gradually slowing), new visual images are compared to and built into relationships with images already stored and with percepts from other senses. It relies on memory to such an extent that expectation can influence perception itself. As an old Arab saying has it: 'the eye is blind to what the mind can't see'.

### 2.2.2 Visual performance

The *contrast sensitivity* of the eye is very good in good lighting. In full daylight a luminance difference between surfaces as little as 1% can be distinguished, but under poor lighting conditions, surfaces with up to 10% luminance difference may be perceived as equal. Contrast is expressed as the ratio of luminance difference to the lower of the two luminances:

$$C = \frac{L_1 - L_2}{L_2} \tag{2.4}$$

*Visual acuity*, or sharpness of vision depends on illuminance. Acuity (a) is measured by the smallest detail perceived, expressed as the reciprocal of the visual angle ( $\sigma$ , in minutes of arc) subtended at the eye by opposite extremes of the least perceptible detail:

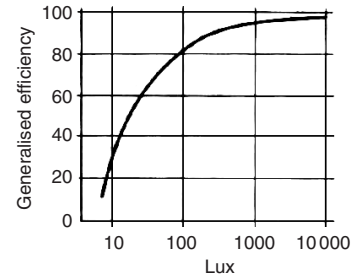
- if  $\sigma = 2'$ , then  $a = 1/2 = 0.5$ ,
- or if  $\sigma = 3'$ , then  $a = 1/3 = 0.33$ .

Same as with contrast sensitivity, the law of diminishing returns applies: a small increase at a low level of illuminance produces

a large improvement in acuity, but a similar increase at a higher level of illuminance is barely noticeable.

*Visual performance* is a function of time that is required to see an object, or of the number of items (e.g. characters) perceived in unit time. The time required to perform a certain visual task decreases (i.e. the performance increases) with the increase of illuminance.

The above three terms are measures of the same stimulus-response relationship. The three together give a good measure of the efficiency of the visual process. Fig. 2.12 shows the variation of visual efficiency with task illuminance. The curve is a good example of the law of diminishing returns.



**Fig. 2.12** Visual efficiency curve:  $\eta$  vs E.

### 2.2.3 Lighting requirements

The *adequacy* of lighting is a quantitative requirement, which depends on the visual task: the contrast, the fineness of detail and the speed at which the view changes. To set the required lighting level, the risk of possible errors must be judged and balanced against the affordability of lighting. As visual efficiency of people reduces with age, it is advisable to provide better illuminance for older people. Recommended or prescribed illuminance values also depend on socio-cultural, as well as economic factors. Table 2.3 compares recommended illuminances for only two different tasks in four countries:

It must be noted that such recommended values show an increasing trend, partly due to more efficient lamps becoming available and partly because of increased affluence and expectations. For currently recommended illuminance values, see D.2.6.

The *suitability of lighting* is a qualitative requirement and has at least four component factors.

1. Colour appearance and colour rendering. As our eyes developed over millions of years to operate under natural lighting conditions, their sensitivity corresponds to the sunlight spectrum. Some research suggests that at high levels of

**Table 2.3** Recommended illuminances

		Visual task	
	Year	Fairly severe (drawing office) (in lx)	Very severe (watch repair) (in lx)
Soviet Union	1952	50–150	150–300
Hungary	1952	150–300	300–500
UK	1973	750	1 500
USA	1955	1500	5000–10 000

illuminance we expect light of a higher CT (i.e. daylight) and daylight gives the norm for colour rendering, it is the best to reveal all colours. With low levels of illuminance, a light of lower CT is expected and preferred ('warm' colours: the light of fire or candle or an oil lamp).

2. Colour appearance of an environment is associated with mood and the expected 'atmosphere'. These are psychological and aesthetic effects. The architectural character of a space can be enhanced, but also counteracted, changed or even destroyed by lighting. E.g. one does not want 2000 lx illuminance of a blue-white colour (>20 000°K CT) in an intimate restaurant. Light can be handled purely functionally but it can be an important design element from the aesthetic viewpoint.
3. Directionality of light must suit the functional as well as the psychological requirements of a visual task. A more diffuse light is normally judged as more 'pleasant', but it will cast little or no shadows, so it may create a hazy or even an eerie atmosphere. Where 3-D perception is essential, a more directional lighting is necessary, as shadows will reveal form and texture.
4. Glare should be avoided, but the extent of acceptable (desirable?) glare must suit the visual task. It will be discussed in more detail in Section 2.2.4.

#### 2.2.4 Glare

Glare can be caused by a saturation effect or by excessive contrast. We can distinguish discomfort glare and disability glare, depending on the magnitude of the effect.

*Saturation glare* can be caused when the average luminance of the field of vision is in excess of 25 000 cd/m<sup>2</sup> (80 000 asb). This can happen on a white sandy beach ( $\rho = 0.9$ ) with full sunshine (100 000 lx), giving 90 000 asb (or 28 600 cd/m<sup>2</sup>) or by looking directly into a bright light source. Isolated bright white clouds, when sunlit, can reach similar luminances. This would cause *disability glare*, i.e. vision will be impaired. Some sources distinguish 'direct glare' caused by a light source itself and 'indirect glare' caused by reflective illuminated surfaces.

The eye (both the pupil and the retina) adapts to the average luminance of the visual field. While, driving at night, this average luminance is quite low, even when the high beam of headlights illuminates part of it. So, much of the visual purple is removed from the retina and the pupil is wide open. An oncoming car, travelling with high beam on, can cause disability ('blinding') glare as the pupil closes down to minimum in a few seconds, so only the headlights are visible, not the rest of the field. Such disability glare can normally be avoided, but discomfort glare is more of a problem.



Glare is caused by contrast, and if the luminance ratio ( $L_{\max}/L_{\min}$ ) within a visual field is greater than about 15 (some sources suggest 10), visual efficiency will be reduced and discomfort may be experienced. When looking at a theatre stage (with low level lighting) with a brightly lit “Exit” sign at the edge of my field of view, my vision is somewhat impaired, but it certainly causes discomfort and annoyance.

Viewing a computer screen when facing a window with a sunlit background is very uncomfortable. Reflected glare is caused when a lamp behind me is reflected from the computer screen, or when trying to look at a glossy photo and my anglepoise lamp gives a reflection into my eyes. These are often referred to as ‘veiling reflections’. In a general office fitted with bare fluorescent lamps all over the ceiling, these may be in my visual field and cause discomfort glare.

Contrast grading is one way of reducing glare. If the luminance of the visual task on my desk is taken as 100%, its immediate surrounding should not be more than 50% and the rest of the visual field not more than 20%

Some sources distinguish the ‘field of vision’ (= visual field), the area looked at when neither the head nor the eyes move (a visual angle of about 2°) and the ‘field of view’ (the immediate surrounding), that is visible with the head fixed, but the eyes moving (a visual angle up to about 40°). The ‘environment’ is taken as that with the head turned but the body (the shoulders) fixed (up to 120° vertically and 180° horizontally).

Some contrast grading (below the above limits) will assist in focusing attention on the task.

The glare index concept will be discussed in Section 2.5.5, in the context of electric lighting design.

## 2.3 Daylight and sunlight

Light outdoors can arrive directly from the sun, which is referred to as *sunlight*, or can be diffused by the atmosphere, e.g. by clouds. The term *daylight*, in a loose sense is often used for both, but in technical language, it means only the diffused light.

### 2.3.1 Sky conditions

The available light is determined by sky conditions. A fully **overcast sky** acts as a diffuse light source, i.e. the whole sky hemisphere is a source of light. The CIE standard overcast sky has a luminance distribution defined as a function of altitude angle ( $\gamma$ ). If the zenith

luminance is  $L_z$ , then at any altitude angle

$$L_\gamma = \frac{L_z}{3} \times (1 + 2 \sin \gamma), \quad (2.5)$$

i.e. the zenith luminance is three times that at the horizon and it increases from horizon to zenith following a sine function. The average luminance is found at an altitude angle of  $42^\circ$ .

The illuminance produced by an overcast sky strongly depends on the solar altitude angle (ALT) behind the clouds. In the absence of measured data, it can be estimated as

$$E \approx 200 \times \text{ALT}. \quad (2.6)$$

Under **clear sky** conditions, direct sunlight can give an illuminance of 100 klx (1 kilo-lx = 1000 lx), but if the sunlight itself is excluded, the sky can give 40–50 klx diffuse illuminance. With clear skies the sky luminance is taken as uniform.

In many climates, **intermediate sky** conditions occur most of the time. The average illuminance produced by such a sky (excluding direct sunlight) can be estimated as

$$E \approx 500 \times \text{ALT}. \quad (2.7)$$

Measured illuminance data are rarely available. More locations have measured solar irradiance data. From this, the illuminance can be estimated by using the luminous efficacy<sup>†</sup> values of solar radiation. This is defined as

$$\text{Luminous efficacy} = \frac{\text{illuminance}}{\text{irradiance}} = \frac{\text{lx}}{\text{W/m}^2} = \frac{\text{lm/m}^2}{\text{W/m}^2} = \frac{\text{lm}}{\text{W}}.$$

Often used such values (in lm/W) are:

Sunlight	
ALT = $7.5^\circ$	90
ALT > $25^\circ$	117
Average	100
Sky light	
Clear	150
Average	125
Global (sun + sky)	100–115

<sup>†</sup> Note that whilst *efficiency* is a non-dimensional number comparing quantities of the same dimension, *efficacy* is the term used for the comparison of unlike quantities, therefore its dimension must be stated.

### 2.3.2 Daylight illuminance

Measured outdoor illuminance data are usually presented in terms of frequency of occurrence (in %), in the form of an ogive curve, such as that shown in Fig. 2.13. Measurements usually exclude direct sunlight, so the horizontal scale of this diagram is diffuse illuminance (on a horizontal surface, from an unobstructed sky) and the vertical scale is percentage frequency. From the example of Brisbane, it can be seen that e.g. 30 klx is exceeded some 22% of the time (taken for the year between 9:00 and 17:00 h) and 10 klx would be exceeded some 80% of this time.

The above are planar illuminance data, i.e. measurements of illuminance on a plane, in this case a horizontal plane surface. This, however, does not give a full picture (Fig. 2.14).

Overcast sky illuminance is diffuse, i.e. light is received at a point from all directions of the sky hemisphere. A theoretical perfectly diffuse field of light would mean a uniform spherical illuminance. A spherical light meter would measure the *mean spherical illuminance* (i.e. a scalar illuminance,  $E_s$ ), whether it is uniform or not. The *illuminance vector* is given by the largest difference between illuminances from two diametrically opposite directions ( $\Delta E_{max} = E_{max} - E_{min}$ ). This is the magnitude of the vector and its direction is defined by a horizontal (bearing or azimuth) and a vertical (altitude or elevation) angle. The vector/scalar ratio ( $v/s$ ) is a measure of directionality of light.

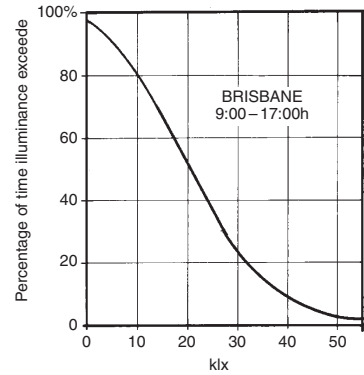
$$v/s = \Delta E_{max}/E_s, \tag{2.8}$$

e.g. if the largest difference is found as  $\Delta E_{max} = 200$  lx and the mean spherical illuminance is  $E_s = 100$  lx, then the ratio is  $v/s = 200/100 = 2$ , but if  $E_s = 400$  lx, then  $v/s = 200/400 = 0.5$ .

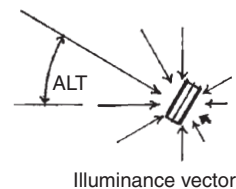
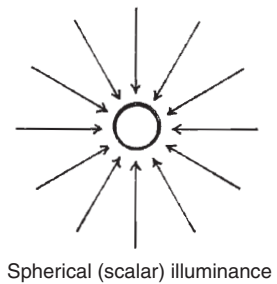
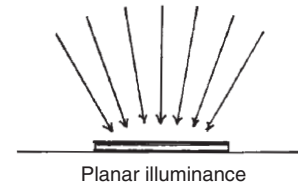
In a completely uniform diffuse field  $\Delta E_{max} = 0$ , thus  $v/s$  is also 0.

In a monodirectional light, if the beam of light (within 1 sr) gives 800 lx, the  $\Delta E_{max}$  is also 800 lx and  $E_s$  is likely to be  $800/4 = 200$  lx (the 800 lx from 1 sr is averaged over the surface of the sphere,  $4\pi r^2$ , so  $v/s = 800/200 = 4$ ). This is the maximum value possible, with a monodirectional light, so the theoretical limits for  $v/s$  ratio are 0–4, and in real situation, values between 0.2 and 3.5 are encountered.

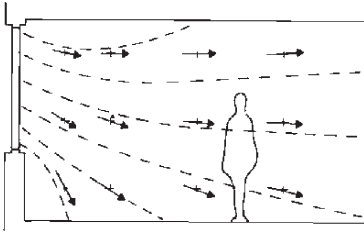
Outdoors, under an overcast sky the illuminance vector is likely to be vertical and  $v/s$  ratios around 2.5 are found, depending on the reflectance of the ground. The light from an overcast sky entering through a window is likely to have a vector altitude of  $42^\circ$  (the altitude of average luminance), near the window. Further into the room it tends to become near horizontal (Fig. 2.15). If a person A faces the window, talking to B whose back to the window, A will see B only in silhouette. (This can be improved by light coloured room surfaces, with reflected light reducing the  $\Delta E_{max}$ .)



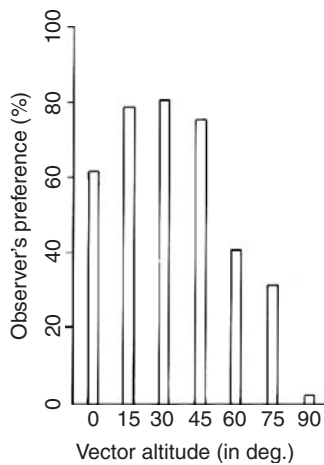
**Fig. 2.13** Frequency distribution of outdoor illumination (direct sunlight excluded).



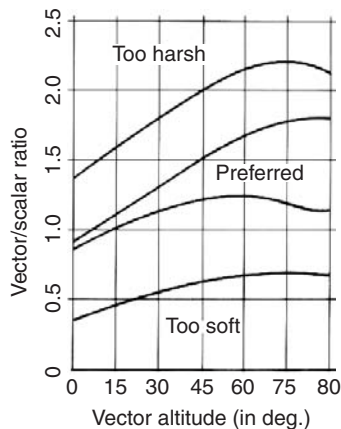
**Fig. 2.14** Interpretation of the vector/scalar ratio.



**Fig. 2.15**  
Illuminance vectors in a side-lit room.



**Fig. 2.16**  
Preferences for vector altitude.



**Fig. 2.17**  
Preferred vector/scalar ratios.

There is evidence that most people when looking at a human face prefer it to be illuminated with a v/s ratio between 1.1 and 1.5, and a vector altitude of 15–45° (Figs 2.16 and 2.17).

### 2.3.3 Luminance distribution

The entry of sunlight through a window may or may not be desirable and it depends very much on the visual task to be performed. Sunlight (solar radiation) has a strong heating effect, which may be desirable in winter, but not under warm conditions. The question of 'right to sunlight' will be discussed in Section 2.3.4; here its illumination effects are considered.

On the surface of a desk near a window, the daylight illuminance may be around 200 lx. The luminance of white paper ( $\rho = 0.8$ ) may be some 160 asb. If a beam of sunlight reaches part of this surface, giving an illuminance of 10 klx, it will produce a luminance of some 8000 asb. The luminance ratio within the field of view will be 8000:160 = 50, which is far too much, when anything above 15 would cause glare.

The preferred luminance ratio (as mentioned in Section 2.2.4) would be: task:surround:background = 1:0.5:0.2.

The immediate response of people would be to move away or draw the blinds. But then the daylight will not be enough, so they will switch on the electric light.

For critical visual tasks, such as an artist's studio, large 'north-light' windows are preferred ('south-light' in the southern hemisphere), which would maximise diffuse light but avoid direct sunlight.

The design of fenestration is affected by conflicting requirements. Increased reliance on daylighting, as an energy conservation measure, may make a larger window desirable. This may increase the risk of glare. Even if sunlight is excluded, a view through the window of a sunlit wall, a water surface, or a sandy beach, of sunlit clouds or a bright sky can cause glare. Glare occurring in daylighting can be reduced by the following measures:

1. Reduce luminance of the view by using low-transmittance glass ( $\tau \approx 0.3$ ) at least for critical (upper) parts of the window, or by the use of blinds or curtains.
2. Increase the luminance of areas near the high luminance view, e.g. by having windows in other walls to illuminate the surfaces adjacent to the window considered or by using supplementary top lighting.
3. Increase the luminance of the window's surrounds by using light colour surfaces and contrast grading, i.e. having high reflectance surfaces next to the window, reducing away from the window. With very large windows, this measure will not work.

4. Use external protective devices (similar to shading devices) to block out the view of the brightest problem-area, most often the sky.

Care should be taken with the design of such devices. If the sunlit device itself is visible (especially a white or bright metallic device), it can cause glare. If the device or a screen allows sun penetration in narrow beams, producing alternating patches of sunlight and shade, it may be worse than the unprotected window.

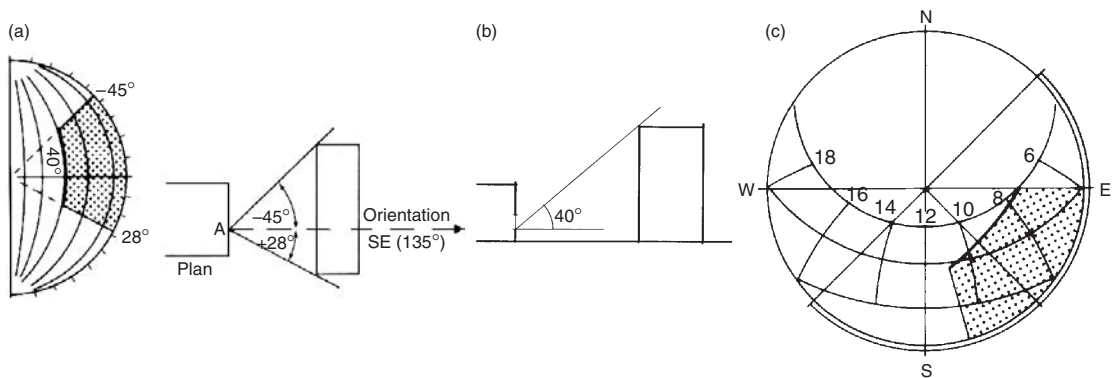
### 2.3.4 Overshadowing

Thermal effects of solar radiation have been discussed in Part 1 (especially in Section 1.4.1) where the use of sun-path diagrams and the shadow angle protractor have also been introduced. These can be put to use also for the control of sunlight.

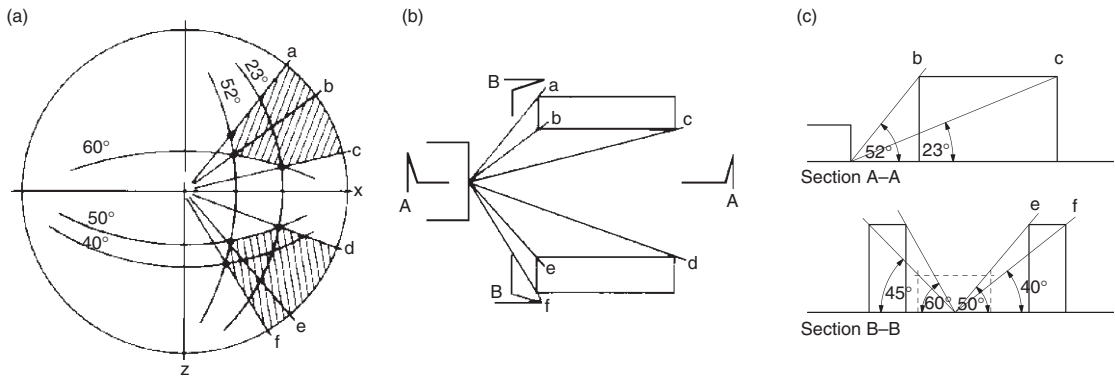
In temperate climates it is desirable to admit some sunlight into habitable rooms (including schools or hospital wards), if not for physical, certainly for psychological reasons. Some codes of practice prescribe that such rooms should be able to receive sunlight for at least one hour per day for 10 months of the year (if available). This 'right to sunlight' has precedence from the eighteenth century, but the problem became more acute after the 1973 energy crisis when installations of various solar energy devices proliferated. It will be discussed in some detail in Part 4.

A task before starting a design would be to assess any obstructions around the site and establish the extent and duration of overshadowing. Fig. 2.18 shows a method of assessing overshadowing in a simple case.

Take point A, at the ground floor window sill level of the proposed building. Lines drawn on plan to the edges of the obstructing existing building can be transferred to the shadow angle protractor,



**Fig. 2.18**  
Assessment of overshadowing.



**Fig. 2.19**  
A somewhat more involved case.

to delineate the horizontal extent of overshadowing (in this case  $-45^\circ$  and  $+28^\circ$ ). Then on a section, the line drawn from point A to the top edge of the existing building gives the vertical shadow angle (VSA), in this case  $40^\circ$ , which is represented by the  $40^\circ$  arc of the protractor. This completes the shading mask.

If this is superimposed on the sun-path diagram for the location, according to orientation (in this case S/E, or  $135^\circ$ ) the times end dates of overshadowing can be read: on midsummer day only for a few minutes at about 7:30, but on equinox dates from 6:00 to about 11:00 h.

Fig. 2.19 shows the same procedure for the effect of two buildings opposite, but sideways offset. Here two sections are necessary (A-A and B-B). Use the shadow angle protractor so that its centreline is in the plane of the section.

Method sheet M.2.1 presents the use of this technique for a site survey, to examine the extent of overshadowing of a given point on the site.

## 2.4 Design methods

Daylight may be introduced into a building using a variety of techniques, side-lighting or top-lighting strategies. Integration of daylighting with building design can have a decisive influence on the architectural form. In daylighting design, for the positioning and sizing of apertures, there are three main issues to be considered:

- to satisfy the visual tasks (provide enough daylight)
- to create the desired 'mood' and provide visual focus
- to integrate daylighting with the architecture.

For the first of these, for quantifying daylight in buildings (or predicting daylight performance from a plan) four methods will be described in this section. Some of these use luminous quantities (flux, illuminance), which others are based on relative quantities: daylight factors (DF).

### 2.4.1 Total flux method

The building (or a room in the building) is considered as a closed box, with an aperture (a window) that will admit a light flux. The illuminance on the plane of the window ( $E_W$ ) must be known. If this is multiplied by the window area ( $A$ ), the total flux entering the room is obtained (Fig. 2.20).

$$\Phi_t = E_W \times A \text{ (lm)}. \quad (2.9)$$

This will however be reduced by three factors:

1.  $M$ , the *maintenance factor*, which allows for dirt or other deterioration of the glazing in use.
2.  $G$ , or *glass factor*, allowing for the type of glazing, other than clear glass.
3.  $B$ , 'bars' or framing factor, allowing for obstruction due to solid elements of the frame and sashes, that would reduce the effective area.

(See data sheet D.2.2 for all three factors.)

Thus, the effective flux entering will be

$$\Phi_e = \Phi_t \times M \times G \times B \text{ (lm)}. \quad (2.10)$$

If this flux were to be uniformly distributed over the floor area, the illuminance would be

$$E_{av} = \Phi_e / A \text{ (where } A \text{ is the floor area)}, \quad (2.11)$$

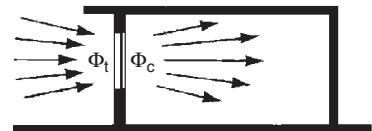
which is not the case, but it can be taken as the average illuminance. The actual illuminance at any particular point in the room (on the work plane) will depend on the *utilization factor* (UF) at that point. This is determined by

- (1) geometrical proportions of the room, expressed by the room index: RI

$$RI = \frac{L \times W}{(L + W) \times H} = \frac{\text{horizontal surfaces}/2}{\text{vertical surfaces}/2};$$

where  $L$ ,  $W$  and  $H$  are length, width and height of the room;

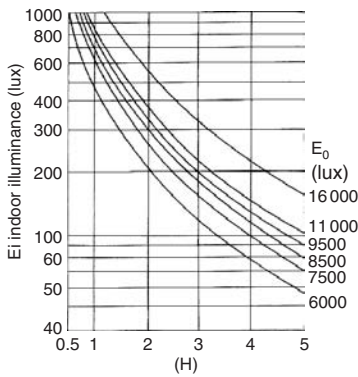
- (2) reflectance of ceiling and wall surfaces;



**Fig. 2.20**  
Flux entering through a window.

- (3) type of fenestration;
- (4) position of the point relative to the window(s).

Such UFs are usually presented in extensive tables. The method has been widely used in the USA, but it is suggested that its use be restricted to roof lighting, for a general illumination of the work plane. Data sheet D.2.1 is an example of such a UF table, also giving the uniformity criteria for the main types of roof lighting.



**Fig. 2.21**  
Daylight design diagram.

**2.4.1.1 Daylight design diagrams** have been produced (Paix, 1962/82) by the Australian Experimental Building Station (EBS), based on ‘design sky’ outdoor horizontal illuminance values, those exceeded in 90% of the time (from 5:00 to 17:00 h) (see also Fig. 2.13). For Australian cities this varies from 6000 lx (Hobart) to 16 000 lx (Darwin).

Fig. 2.21 shows the work-plane illuminance as it reduces with the increase of distance from the window. This distance is expressed as a multiple of the window head height (H) above the work plane. The illuminance values read are valid for a horizontal strip window of infinite length. For windows of finite length and for any external obstruction, the correction factors given in Fig. 2.22 are to be applied.

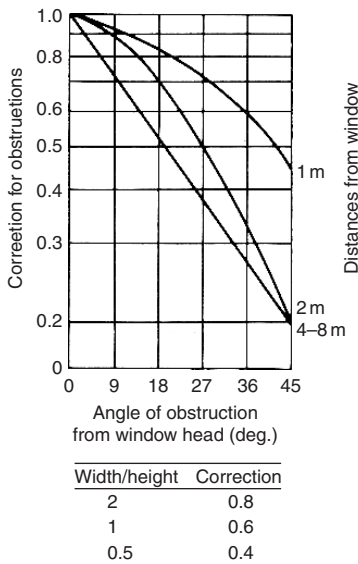
**2.4.2 Daylight factor**

It has been observed that although overcast sky illuminance may vary between quite wide limits, the ratio between illuminance at a point indoors to that outdoors remains constant. This ratio is the DF expressed as a percentage.

$$DF = \frac{E_i}{E_o} \times 100 (\%). \tag{2.12}$$

As outdoor lighting conditions are highly variable, design can only be based on the ‘worst conditions’ (that are judged to be ‘reasonable’). This approach has the same theoretical basis as the selection of ‘design outdoor temperatures’ discussed in Section 1.6.1. Such ‘worst conditions’ would occur when the sky is overcast. In Northern Europe and North America, the 15th percentile outdoor illuminance (of the daylight period, usually taken as between 9:00 and 17:00 h) is accepted, that would be exceeded in 85% of the time.

However, in many countries this *design sky* illuminance has been standardized as 5000 lx. Thus, e.g. a 2% DF would mean  $5000 \times 2/100 = 100$  lx indoor ‘design’ illuminance, that is likely to be exceeded 85% of the time. For the remaining 15% of time, the electric lighting can be switched on, or behavioural adjustments can be made (e.g. moving closer to the window). The adaptation mechanisms of the human eye are such that an illuminance



**Fig. 2.22**  
Corrections for narrow windows and obstructions.



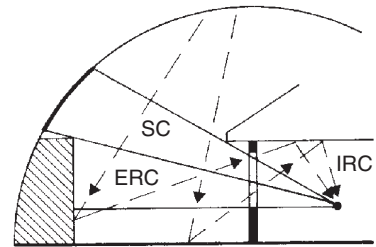
of 1000 lx can be just as comfortable as 100 lx and – as Fig. 2.12 shows – over 100 lx there is little change in visual efficiency. Beyond any individual limit of comfort negative control is easy, such as drawing a curtain or blind. Thus, the prediction of DF becomes an important design tool.

Daylight can reach a point of the work plane by three routes (Fig. 2.23), thus three components of DF are distinguished:

- (1) SC, the sky component: light from a patch of sky visible from the point considered;
- (2) ERC, the externally reflected component: light reflected by outdoor objects, e.g. other buildings;
- (3) IRC, the internally reflected component: any light entering the window, but not reaching the work plane directly, only after reflection(s) by internal surfaces, notably the ceiling.

Thus,  $DF = SC + ERC + IRC$ .

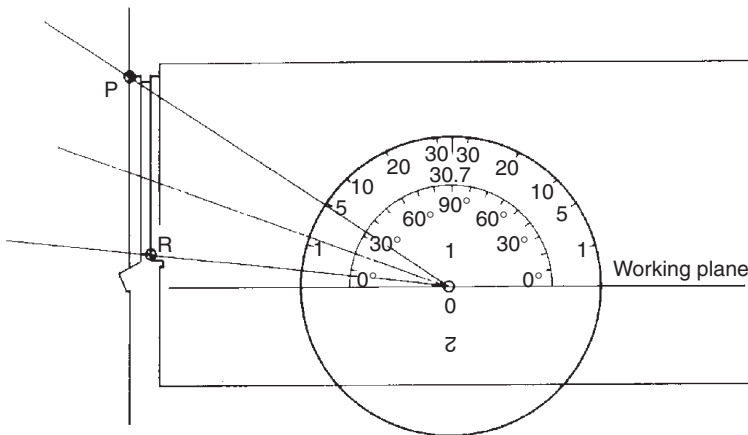
(2.13)



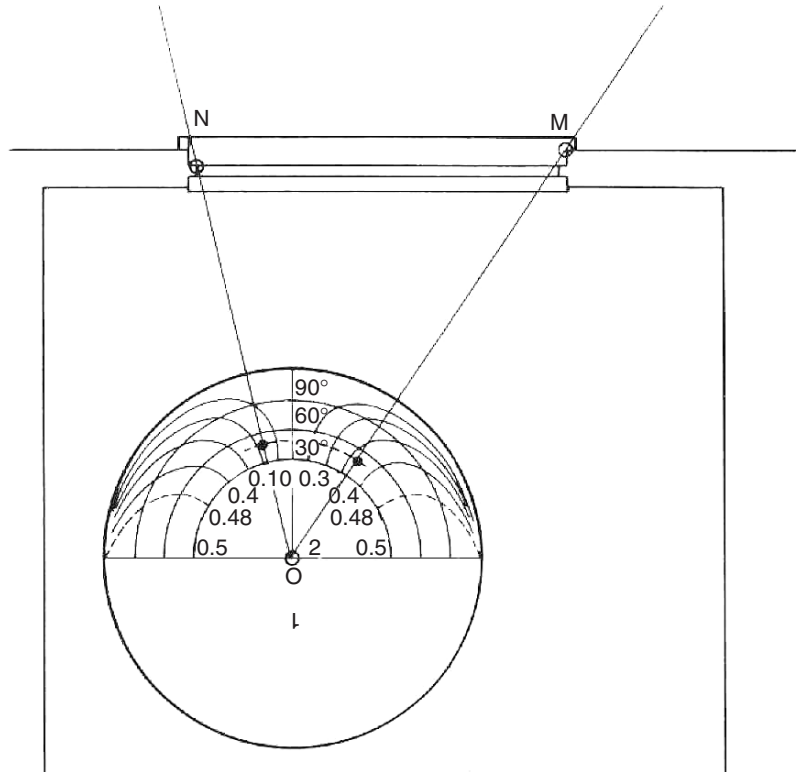
Consequently, this is referred to as the *split flux method*.

For the prediction of the sky component, a set of protractors have been produced by the British BRE (Longmore, 1968). Such a (circular) protractor consists of two sides: the first is to be used with a sectional drawing of the room and window (Fig. 2.24) to get the initial sky component (for an infinitely long strip-window) and the second, which is to be used with a plan of the room (Fig. 2.25) to get a correction factor for the window of a finite length. The set consists of 10 protractors, one of which, No. 2, for a vertical window under a CIE overcast sky is given in data sheet D.2.3 and its reduced simplified image is used in the following explanations, with Figs 2.24 and 2.25).

**Fig. 2.23**  
Daylight flux split into three components.



**Fig. 2.24**  
Determine initial sky component.



**Fig. 2.25**  
Correction factor to the sky component.

For side 1: place the protractor on the section, with its base on the work-plane and its centre at the point considered. Draw two lines: to the window head (P) and sill (R). Read the values at the outer scale: in this case 4.8 and 0.2. The difference between the two, 4.6%, is the *initial sky component*. If the sill is at or below the work-plane, the initial reading from the OP line is the value wanted. Determine the mid-point of the window and read this *average altitude angle* from the inner scale (which is a simple angle-protractor), in this case 20°.

For side 2: place the protractor on the plan, with its centre at the point considered and its base line parallel with the window plane. There are three concentric semi-circular scales, for 30°, 60° and 90° altitude angles. Interpolate an arc for the average altitude angle determined: in this case 20°. Draw radial lines from point O to the two edges of the window (M and N) and mark the points where these intersect the arc interpolated. Read the values on the inner scale, following the drooping lines: in this case 0.32 and 0.18. As these are on either side of the centreline, the correction factor will be the sum of the two. If both were on the same side, i.e. if the point considered is outside the lines of the window width, the

correction factor will be the difference between the two values. In this case, the sum is 0.5, thus the sky component will be

$$SC = 4.6 \times 0.5 = 2.3\%.$$

Other protractors are available for sloping and horizontal glazing and unglazed apertures, both for CIE and uniform skies.

If there is an obstruction outside the window, the outline of this must be established in section and the OR line (of Fig. 2.24) should be drawn to the top of this obstruction. The SC will be taken above this line only. The angle below this line should also be read and treated as if it were another patch of sky, but finally multiplied by the reflectance of that obstruction's surface (if not known, use  $\rho = 0.2$ ). This will give the ERC.

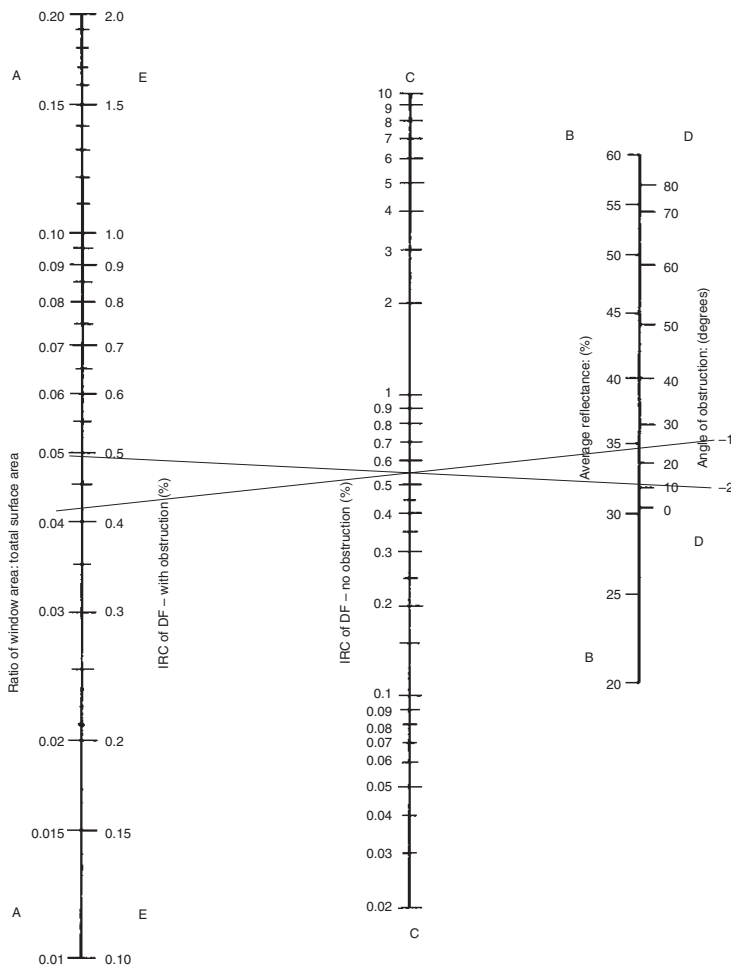
The IRC can be determined by using the nomogram (given in D.2.4) as indicated in Fig. 2.26.

1. Find the ratio of window area to total surface area of the room (ceiling + floor + walls, including the window) and locate this value on scale A.
2. Find the average reflectance of room surfaces, which should be the area-weighted average, but if the ceiling  $\rho \approx 0.7$  and the floor  $\rho \approx 0.15$  then the small table (1) included with the nomogram can be used. First find the ratio of wall area (incl. the window) to the total surface area (as in 1 above) and locate this value in the first column. The average reflectance is then read in the column headed by the wall reflectance. Locate this  $\bar{\rho}$  on scale B.
3. Lay a straight-edge across these two points and it will give the IRC on scale C.
4. If there is an obstruction outside the window, determine the altitude angle of its top edge and locate this on scale D.
5. A straight-edge laid across this point (D) and the point on C previously determined will give the IRC on scale E.

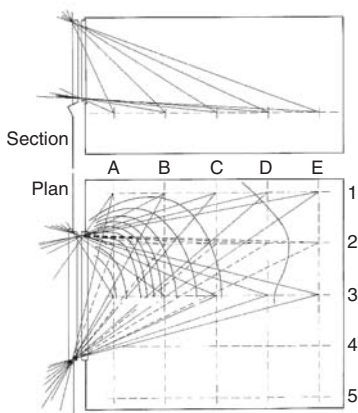
A correction factor should be applied to this IRC for the deterioration of internal decoration (D-factor), which depends on location and room usage, as given in Table 2 of D.2.4.

### Example 2.1

Assume a room  $5 \times 4 \times 2.7 \text{ m}^3$ , with one window of  $2.5 \times 1.5 \text{ m}^2$ . The total surface area is  $5 \times 4 \times 2 + 2 \times (5 + 4) \times 2.7 = 88.6 \text{ m}^2$ , The window area is  $3.75 \text{ m}^2$ , thus the ratio is  $3.75/88.6 = 0.042$ . If  $\rho_{\text{walls}} = 0.3$ , from Table 1 of D.2.4, the average will be 0.35 (35%). This defines line 1 in Fig. 2.26 showing an IRC of 0.55%. If the altitude of obstruction is  $15^\circ$ , this gives line 2 and the corrected IRC is 0.5%.



**Fig. 2.26**  
Use of the IRC nomogram (see D.2.4 for full size version).



**Fig. 2.27**  
Daylight factors at grid-points and interpolation of DF contours.

The three components can then be added (as Eq. 2.13) and three further corrections should be applied to the sum:

M (maintenance factor), G (glass factor) and B (bars, or framing factor), which are the same as used in the total flux method, and are given in D.2.1.

If a grid of (say) 1 m spacing is established over a plan of the room, the DF can be calculated at each of these grid-points and contours of DF can be drawn by interpolation (Fig. 2.27). This would give an indication of the distribution of light across the whole work plane (see also Fig. 2.31).

**2.4.2.1 The pepper-pot diagram** is a derivative of the split flux method. The diagram itself is given in D.2.5 and it is to be used

with an internal perspective of the window and the wall it is in. This is a one-point perspective and must be drawn to a perspective distance of 30 mm, as explained in method sheet M.2.2.

When this is done, lay the pepper-pot diagram (a transparent copy) over the window, with its base line at work-plane level and its centre point (O-point) corresponding to the point considered (the view point, VP). Count the number of dots within the window area. Each dot represents 0.1% of SC. In the example shown in M.2.2, we have 11 dots and 2 half dots, i.e. a total of 12, thus the SC = 1.2%

Any external obstructions can be drawn on the perspective within the window aperture. Any dots falling on such obstructions can be counted the same way, but the result must be multiplied by the reflectance of that obstruction to get the ERC. E.g. if we had 6 dots falling over the obstruction, that would count as 0.6%, but multiplied by an assumed reflectance of 0.3, we get an ERC of 0.18%.

The IRC must be found the same way as above, using the nomogram.

### 2.4.3 Models

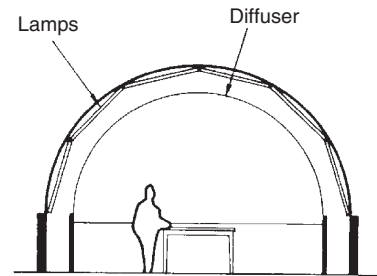
The above methods are fairly easy to use with simple, conventional rooms and simple, conventional fenestration. For more complex geometries and unusual situations, the most reliable way of prediction of daylighting is by the use of physical models. The model should not be too small, a scale of 1:20 is often used, and it is important that internal surface reflectances should match realities as near as possible. If the sky component alone is to be determined, the interior of the model can be painted mat black.

Such models can be tested under outdoor conditions, if a representative overcast sky condition is available. Waiting for such conditions would interrupt any testing program, so artificial skies have been developed, which simulate overcast sky conditions, thus allow the testing to be carried out independent of the changing weather, under precisely controlled conditions.

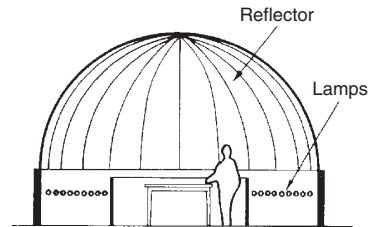
Hemispherical skies can be of two types:

- (1) a hemispherical translucent diffuser (inside of a structural dome) with the lighting installed behind it (Fig. 2.28);
- (2) an opaque dome, with a diffusely reflecting internal surface, with the lighting installation below (lighting upwards) all around an annular space (Fig. 2.29).

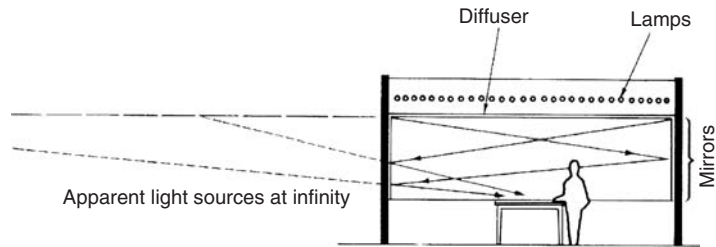
In both cases there would be a model table at the centre, with a space around it for the observers, most often with access from below. Some installations allow the selection (by switching) of a



**Fig. 2.28**  
A back-lit translucent artificial sky.



**Fig. 2.29**  
A reflective solid artificial sky.



**Fig. 2.30**  
A mirror-type artificial sky.

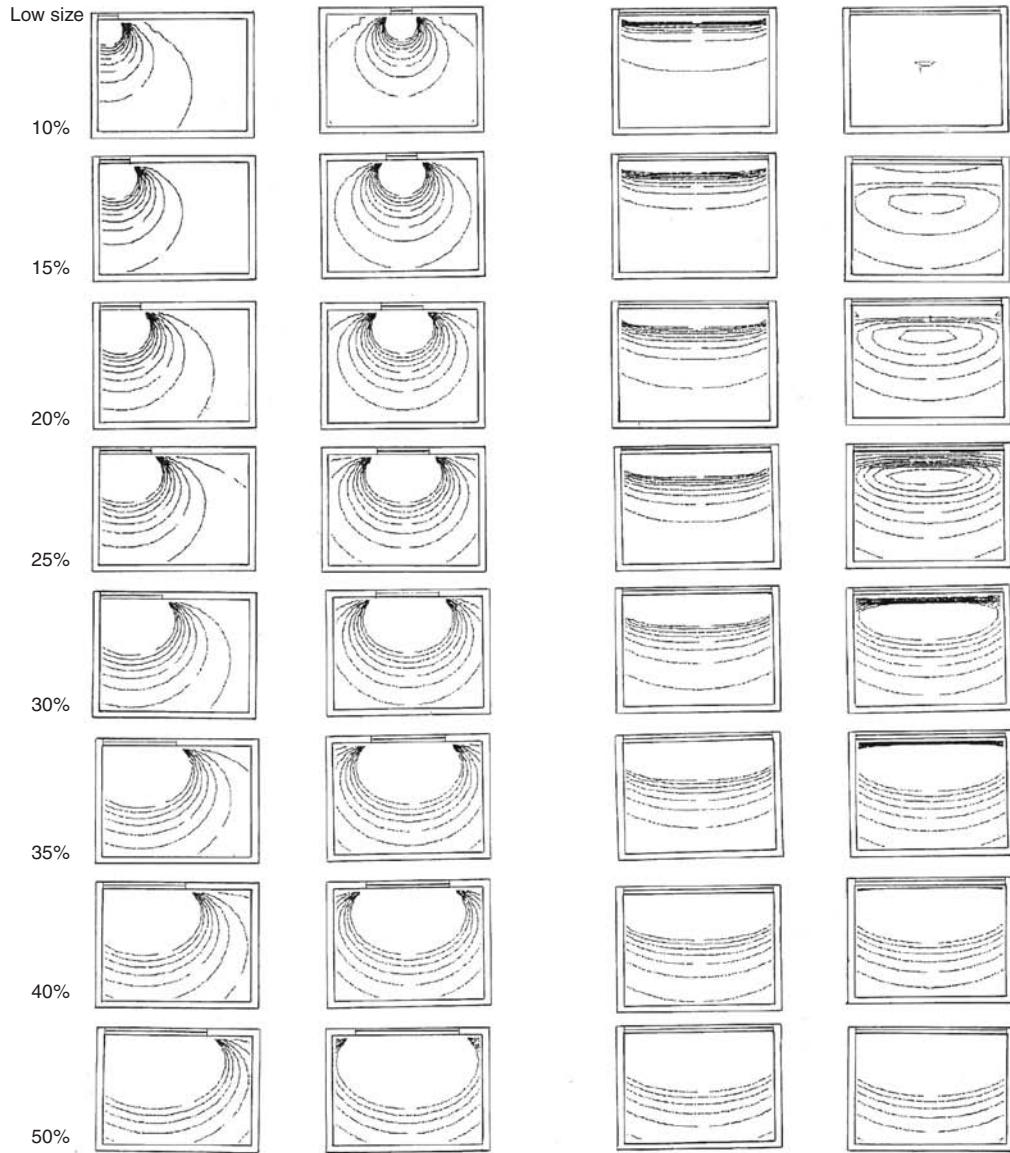
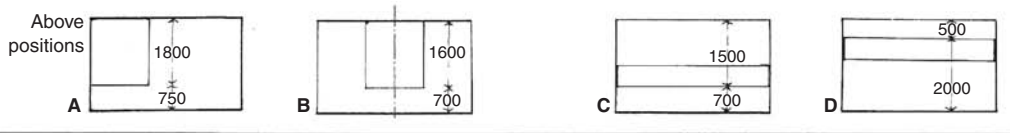
sky with uniform luminance or one with the CIE (1:3) luminance distribution.

Many workers in the field prefer the rectangular, mirror type artificial sky. Here all four walls would be lined with mirrors from table height up to the ceiling. This ceiling would be made of a translucent diffusing material, with the lighting installation behind it. The multiple inter-reflections between opposed mirrors would create the effect of an infinite horizon, which is much closer to reality than domes limited to 6–8 m diameter (Fig. 2.30).

Such artificial skies were developed over 50 years ago and were extensively used by research workers. Indeed, the DF calculation (split flux) method discussed above has been created with the aid of such artificial skies. After the 1958 Oxford conference of the RIBA (which acknowledged the great significance of science in architectural design and education) practically all schools of architecture set up laboratories and built artificial skies. With the rise of post-modern and deconstructivist ideologies and the predominance of formalist attitudes, most of these laboratories fell into disrepair. Only in the last decade, or so, when daylighting came to be recognized as a tool for energy conservation and a contributor to sustainability, have such laboratories been revived to re-gain their role.

The technique of model studies is quite simple: measure the 'outdoor' illuminance, usually on the top of the model, measure the illuminance 'indoors' at various points and find the DF at each of these points as  $DF = (E_i/E_o) \times 100$ . Instruments were made to measure illuminance at many points (with miniature light sensors placed at grid-points) and produce the DF automatically. Measurement systems coupled with a PC can display the DF values at grid-points on the screen and generate the DF contours as well as converting these into illuminance (isolux) contours.

Fig. 2.31 is a reduced scale summary of a study examining the effect of window size, shape and position on daylight distribution. It can be seen that the height of the window determines the depth of daylight penetration, whilst the width influences the sideways spread of daylight.



**Fig. 2.31** A study of daylight distribution. Column A: jamb fixed at side wall, width variable, Column B: centre of window on room centreline, width variable, Column C: full width, sill fixed, height variable, Column D: full width, window head fixed, height variable. Each variant is examined with sizes of 10–50% of wall area (after T. Yamaguchi).

This is the result of using a very simple computer program, which uses the algorithm of the BRE 'split flux' method. Today a large number of computer programs exist, using a variety of algorithms, the most sophisticated ones based on ray-tracing techniques, which can present the results in photo-realistic internal views, with graded indication of illuminance distribution on room surfaces.

Such a program is certainly an impressive presentation tool, but should only be used as a design tool if its workings, its algorithms and its assumptions are fully understood. Responsibility for the performance of a building lies with the designer, not with the authors of the program.

#### 2.4.4 Control of sunlight

Solar geometry has been discussed in some detail in Section 1.4.1, and method sheets M.1.3 and M.1.4 give all the necessary algorithms. Here the subject is the lighting effect of solar radiation (often referred to as *beam sunlighting*) and its control.

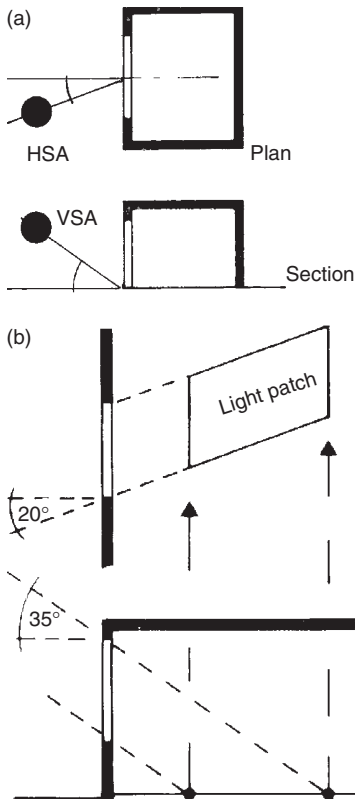
Climatic data, such as hours of clear sunshine can give an indication of the available resource, or the magnitude of the sunlight problem. Solar irradiation data could be converted to luminous quantities by using luminous efficacy values.

In dominantly overcast cool climates, most people would welcome sunlight, whenever it is available. Where glare or excessive contrast may be a problem, the designer must consider the situation: are the occupants free to exercise behavioural adjustments? If not, what are the consequences of direct sunlight?

If it is found that sunlight must be controlled, the first question is: will the sun reach the window considered, or will it be obstructed by external objects (other buildings)? The techniques presented in Sections 2.3.4 and M.2.1 are useful in assessing the duration of obstruction and exposure of a selected point. When the critical time is selected, then the extent of sun penetration can be examined, assuming that there will be sunshine available. This is a purely geometrical task.

The sun's position in relation to the window at that critical time is to be established first. The horizontal shadow angle (HSA) at the time in question is the azimuth difference between the sun's direction and the orientation (see M.1.3). The solar altitude (ALT) must be projected onto a plane perpendicular to the window, to get the VSA. Once these two angles are known, the sun penetration, the sunlit patch on the floor or on the work plane can be constructed, as shown in Fig. 2.32.

A beam of solar radiation incident on a window pane may produce an irradiance of up to  $450 \text{ W/m}^2$ . With a glass transmittance



**Fig. 2.32**  
Construction of sun penetration: a light patch on the floor.



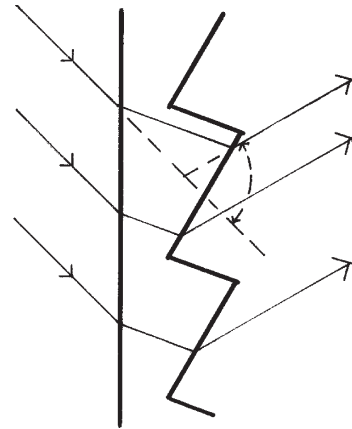
of 0.78 this would be reduced to  $350 \text{ W/m}^2$ . If the luminous efficacy of this is taken as  $100 \text{ lm/W}$  (an average value), the illuminance produced will be some  $35\,000 \text{ lx}$ . In such a situation the general illuminance is also increased, perhaps to  $1000 \text{ lx}$ . So the contrast is 35:1. This is too much for comfort. The occupants must be given the option of some control, such as a curtain or blind. It is however likely that irradiance would be controlled for thermal reasons, preferably by some external shading devices, possibly by some adjustable mechanisms.

The use of tinted (heat absorbing or reflective) glasses may provide a remedy, avoid glare and reduce sunlight. The problem is that they affect diffuse light as much as beam light and as their properties are fixed, they have no selectivity in time: perform the same way in winter as in summer, they would reduce daylighting even when it is scarce.

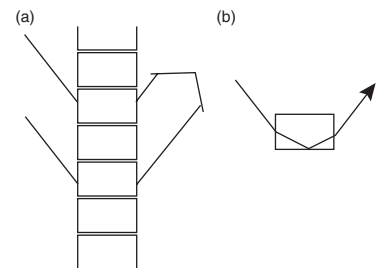
A fixed control should only be used where its necessity is beyond any doubt, otherwise it may be perceived by the users as 'dictatorial'. Some architects adopt the attitude (not just in the lighting context) that they know best what is good for the user. They would argue that one is going to the doctor for advice, not to tell him/her what therapy should be prescribed. Others may perceive this as professional arrogance. It is always useful to allow some degree of control to the user, be it an adjustable thermostat, an adjustable shading device or just a set of blinds.

**2.4.4.1 Beam sunlighting** is very useful in areas of the building that are not reached by daylighting through side windows. Several techniques are in use:

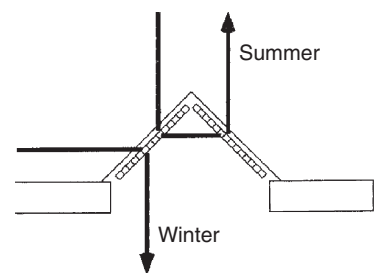
1. *Prismatic glass* is often employed, normally for the top one-third of a window to divert the beam of sunlight (by refraction) upwards, to the ceiling, which will then diffuse it to the rear part of the room (Fig. 2.33).
2. *Laser-grooved acrylic sheets*, divided into small elements by laser cuts to some 90% of the thickness, which will serve the same purpose partly by refraction, but mainly by full internal reflection in each element (Fig. 2.34). These have a particular relevance for roof lights in low latitude climates, where the midday sun can be quite a problem. In a prismatic roof light, they can completely reject high altitude (near zenith) radiation, but would admit the morning and late afternoon sunlight (Fig. 2.35)
3. *Light shelves* have been used for similar purposes for many years. In its simplest form this would be a horizontal element (an extended transom) across the window at a height of about 2.1 m, with a reflective upper surface, which directs the light up to the ceiling (Fig. 2.36). These would work well in a fairly high room ( $\approx 3 \text{ m}$ ). If mounted externally, they could also serve as a shading device for the lower part of the window, but it may



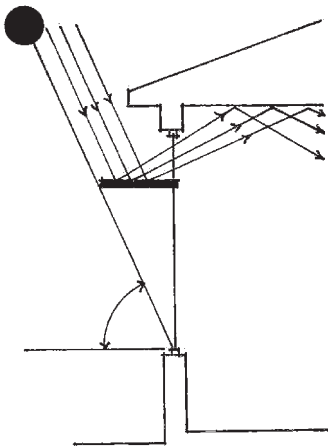
**Fig. 2.33**  
Prismatic glass for beam sunlighting with a deviation angle of  $75^\circ$ .



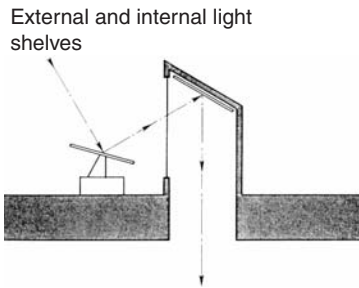
**Fig. 2.34**  
Laser-grooved acrylic sheet.



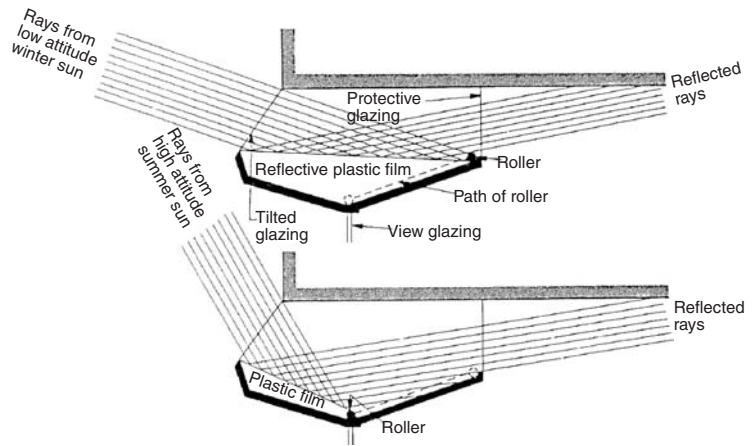
**Fig. 2.35**  
Laser-grooved roof light: at low angle, the sun is admitted, at high angle, excluded.



**Fig. 2.36**  
External and internal light shelves.



**Fig. 2.38**  
Heliostat for beam sunlighting.



**Fig. 2.37**  
A fully enclosed light shelf with a flexible reflective film.

be difficult to keep the top surface clean. The problem is less serious if mounted internally.

Many varieties of such light shelves exist. Some have a specular top surface, some are diffusing. Partially reflecting semi-transparent materials have also been used. Various clever profiles have been developed to respond to the changing solar altitude. Others are adjustable, to compensate for summer-winter difference in the sun's path. One system provides seasonal adjustment by using a flexible reflective film with a 'V'-shaped shelf (Fig. 2.37).

Beam sunlighting is also used for roof lights. As Fig. 2.38 shows a heliostat (a motorised system, the mirror tracking the sun) and a fixed mirror can direct the solar beam downwards where it may enter the room through a diffuser. Such a system serving a single storey building (or the top floor of a multistorey building) can have an efficiency of around 50%. This means that if a solar beam of 60 klx is incident on the primary mirror of 1 m<sup>2</sup>, of the 60 klm light flux some 30 klm is emitted by the ceiling diffuser, which can produce an average illuminance of 300 lx over a 100 m<sup>2</sup> area of the work plane.

A system of mirrors and 'light tubes' would allow the use of such systems over several storeys (Fig. 2.39). These light tubes are made of some highly polished material or lined with a reflective film. A light tube of an elongated oblong section can have 'tapping off' mirrors at several levels and after each of these its size is reduced.

Such a system can have an efficiency over 25% measured from light incident on the primary collector mirror to that emitted by all ceiling diffusers. This efficiency depends on the quality of the reflective surfaces and on how well the light beam is collimated. Unfortunately, the system will work only when clear sunlight is

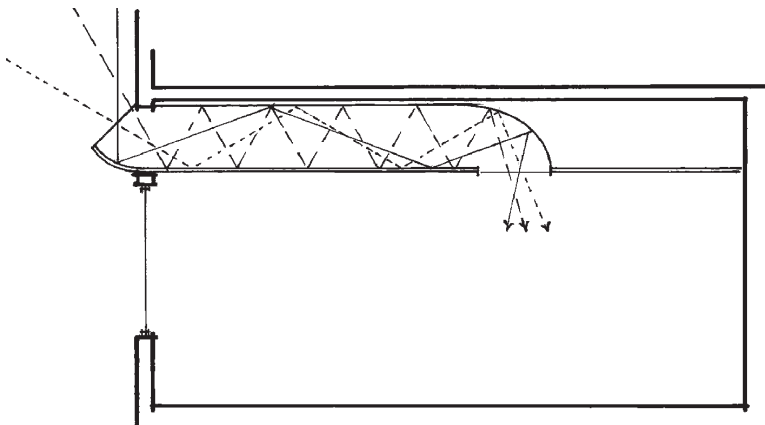
available, so its success very much depends on weather conditions. One must have a stand-by electric lighting system. However, in reasonably sunny climates it can save much operating energy and cost.

A version of light tubes is the 'anidolic ceiling' (non-imaging reflective duct). This has an upward looking 'collector' at the outer end, a 3-4 m long duct within the ceiling space (Fig. 2.40) and a light outlet in the ceiling, to contribute light to the rear part of the room. It can be effective even under overcast conditions, as it 'sees' the upper part of the sky, which is of a greater luminance.

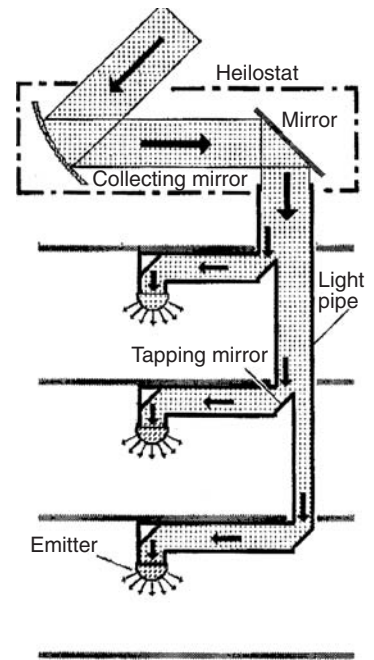
The idea of using optical fibres to convey light of some concentration has been suggested by a group of students in 1975. Fig. 2.41 is reproduced from their original sketch. Since then several research teams have worked on such ideas and recently a group reported on a precision-engineered mini dish (200 mm diameter) connected to an optical fibre conductor of 1 mm diameter, which successfully produced a concentrated beam of 11 kilo-suns (11 000 suns!) conveyed to a diffuser at a distance of 20 m. The technique certainly has a future.

## 2.5 Electric lighting

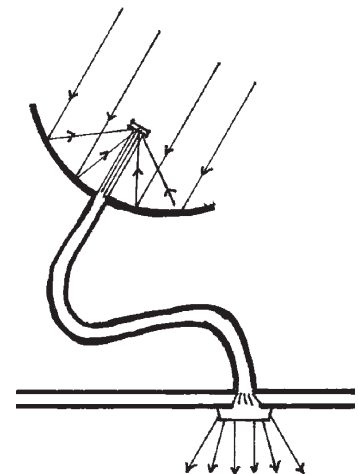
To clarify the terminology: **lamp** is the source of light (bulb or globe are not technical terms). The lamp is usually inside a **luminaire** (which in the past was often referred to as a light fitting), although many lamps can be used without a luminaire, just fitted into a



**Fig. 2.40**  
A ceiling duct: 'anidolic' ceiling.



**Fig. 2.39**  
Beam sunlighting by heliostat and light pipes.



**Fig. 2.41**  
A concentrator/optical fibre lighting system.

lamp holder. *Lamp holders* are the electrical connectors, into which the lamp is inserted or screwed. The generally used ones are the bayonet caps (BC) or the Edison screw (ES), but many other types are available for specialised purposes.

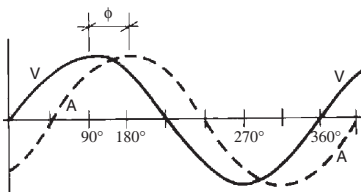
### 2.5.1 Lamps

Electric lamps make use of two different processes of light generation: *thermo-luminescence* and *electro-luminescence* (gas discharge). The former is made use of by the *incandescent* lamps. These have a thin wire (usually tungsten) filament with a high resistance, which is heated by the electric current passing through it. These operate around 2700–3000°K temperature. To prevent oxidation of the filament, it is enclosed in a glass container, in vacuum or partial vacuum with some small quantity of inert gas (krypton, argon or xenon). The life expectancy of these lamps is around 1000 h.

Most of the emission of incandescent lamps (up to 95%) is in the infra-red region, i.e. radiant heat. Their luminous efficacy is 10–18 lm/W.

In operation, some of the tungsten evaporates and condenses on the inside of the glass bulb, causing a slight blackening. To allow higher temperature operation (and smaller lamp size), some halogen elements (iodine, bromine) can be added. These adsorb the tungsten vapour and deposit it back onto the filament. The enclosure of these *tungsten-halogen* lamps is quartz, to withstand higher temperatures and quick changes of temperature. These are available in tubular (double-ended) and single-ended (two-pin) form, both for mains voltage (120–240 V) and low voltage (12–24 V) versions, from 20 up to 2000 W size.

Discharge lamps have no filament; light is produced by excitation of the gas or metallic vapours (mercury or sodium) contained in the lamp. They need a device to start the discharge between the electrodes. The discharge is a chain reaction, exponentially increasing, so a device is needed to limit the current, otherwise the lamp would short the circuit. This can be a resistive ballast or an inductive load with a high impedance. If the latter is used, a power factor correction device is needed.



**Fig. 2.42**  
The effect of inductive load: the current is delayed.

In direct current,  $V \times A = W$  (power is the product of current and potential). With alternating current and inductive load, (a motor or any electromagnetic coil would delay the current behind the voltage changes (Fig. 2.42)), so the actual useful load ( $W$ ) is less than the  $V \times A$  product. If the full cycle is 360°, the delay or phase angle is  $\phi$  and  $\cos \phi$  is referred to as the *power factor*. Thus,

$$\text{Power factor} = \cos \phi = \frac{\text{Actual useful load (W)}}{\text{Apparent load (V} \times \text{A)}}$$

With no phase lag  $\phi = 0$ ,  $\cos \phi = 1$ , but with heavy inductive load  $\phi$  may be as much as  $60^\circ$  and the power factor can go down to 0.5. Most supply authorities set a limit of 0.9. A correction device is a capacitor connected in parallel, which accelerates the current with respect to voltage.

Mercury lamps (MB) have a very discontinuous spectrum but a high efficacy (up to 85 lm/W). The spectrum can be improved by a fluorescent coating of the inner surface of glass (MBF) lamps. A tungsten filament may improve the red end of the spectrum and serve as the current limiting device (MBT). Fig. 2.43 shows a typical mercury lamp and Fig. 2.44 shows a high pressure sodium (tubular) lamp (SONT), which gives a slightly better spectrum than the low pressure SOX lamps.

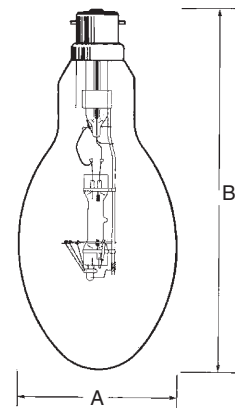
Fig. 2.45 shows a control circuit for a fluorescent lamp, but many others are possible. Fluorescent tubes are actually low-pressure mercury lamps. The discharge is mainly in the UV range. A fluorescent coating on the inside of the tube absorbs this UV radiation and re-emits it at visible wavelengths. The colour of light depends on the composition of this fluorescent coating, hence the many varieties of fluorescent lamps.

Lamps are characterised by their electrical load (W) and by their light emission, both in quantity and quality. The quantitative measure is their light emission in lumens (the term *lamp lumens* is often used). Data sheet D.2.9 shows some typical values. The qualitative measure is their colour appearance and – more importantly – their colour rendering.

Incandescent lamps have a continuous emission spectrum and are adequately characterised by CT. This is  $2700\text{--}3000^\circ\text{K}$  for general service incandescent lamps, up to  $3200^\circ\text{K}$  for photographic or TV studio (halogen) lamps. Gas discharge lamps have a discontinuous, often ‘spiky’ spectrum. The extreme case is the low pressure sodium lamp which has a practically monochromatic emission in the 580–590 nm range, which appears to be an orange/yellow colour and has the worst colour rendering properties. The emission of discharge lamps is determined by the gas and metallic vapour used, but can be modified by a fluorescent coating on the inside of its enclosure. Various colour rendering indices are in use, some quite complicated, but for general purposes a set of simple adjectives is quite sufficient, such as those used in Table 2.4.

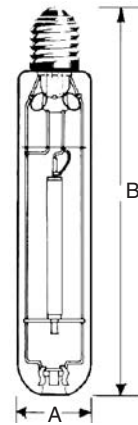
The CIE colour rendering index (CRI) has a scale up to 100. Table 2.5 shows how the CRI matches the five categories of tasks from the colour rendering viewpoint.

A new and promising development is the use of light emitting diodes (LEDs) as light sources. It has been suggested that this signals the end of the incandescent lamp (the ‘good old light bulb’) which dominated the lighting scene for some 125 years (Edison patented it in 1878). Semiconductor light emitting crystals have



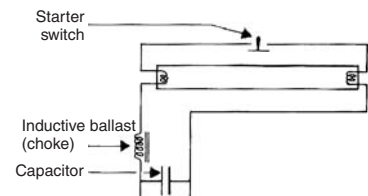
**Fig. 2.43**

A typical mercury lamp, 160 W, A = 76 mm, B = 175 mm.



**Fig. 2.44**

A high pressure tubular sodium lamp (SONT, 70 W), A = 71 mm, B = 154 mm.



**Fig. 2.45**

Control circuit for a fluorescent lamp.

**Table 2.4** Colour properties of tubular fluorescent lamps

Lamp name	Colour rendering	Colour appearance	CCT °K	Efficacy (lm/w)	Uses/remarks
White	Fair	average	3400	70	Most efficient for general lighting
Plus white	Good	average	3600	67	General lighting, good colour rendering
Warm white	Fair	warm	3000	69	General lighting, good efficiency
Daylight (cool white)	Fair	cool	4300	67	General lighting, to blend with daylight
'Natural'	Good	average	4000	52	General lighting for shops, offices
De luxe natural	Good	warm	3600	38	Same with red content for food shops
Kolor-rite	Excellent	average	4000	46	Best colour rendering for general lighting
Northlight (colour matching)	Excellent	cool	6500	42	For matching materials, colours
Artificial daylight	Excellent	cool	6500	30	For analytical colour matching
Home-lite	Good	warm	2600	62	To create a 'warm' atmosphere

**Table 2.5** Categories of colour rendering tasks

	Task	CRI
1A	Accurate colour matching	90–100
1B	Good colour rendering	80–89
2	Moderate colour rendering	60–79
3	Colour rendering of little significance	40–59
4	Colour rendering of no importance	20–39

been made earlier, but as a source of illumination white LEDs were produced only since 1993 (developed by Nakamura). As LEDs emit very little infra-red, they use only 10–20% of the electricity of what is used by incandescent lamps to produce the same quantity of light and their life expectancy is about a hundred times greater.

LED lamps are now used for street lighting in many places and one local authority (Port Phillip, Vic. Aus.) claims that their energy use for street lighting is thereby reduced by 80%.

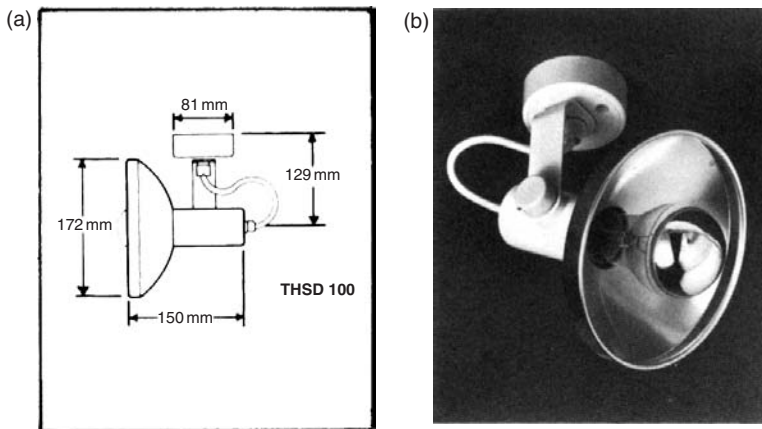
### 2.5.2 Luminaires

In the simplest case the lamp is held by a lamp holder, without any enclosure, shade or light directing device. This is the case with the internally silvered (reflector) lamps, which can be narrow beam *spotlights* or *floodlights* with a broader spread. (The *crown silvered lamps* are used with a shallow parabolic reflector as narrow-beam spotlights. See Fig. 2.46.) There is a very large variety of luminaires available and the choice is often based on the 'look', the appearance of these, rather than on their lighting performance. Essentially there are two basic types: those with fully enclosed lamps and those with partial enclosure or light directing device.

The most popular lamps are the 1200 mm fluorescent tubes and the largest variety of luminaires are available for these. The old 40 W/38 mm diameter tubes have largely been replaced by the 36 W/26 mm diameter ones, but they use the same bi-pin ends, have the same lumen outputs and fit the same luminaires.

Photometrically luminaires can be characterised in relation to the lumen output of the *lamps* they contain, by the light output ratio (LOR):

$$\text{LOR} = \frac{\text{Flux output of luminaire}}{\text{Flux output of lamp(s)}} \text{ expressed usually as a \%}$$



**Fig. 2.46**  
A crown silvered narrow beam spotlight.



and this may be divided into upward and downward parts (divided by the horizontal plane across the centre of the lamp), e.g.

	lm		%
Lamp output	1000		100
– Up	300	ULOR	30
– Down	500	DLOR	50
Luminaire output	800	LOR	80
(Absorbed in luminaire	200		20)

Alternatively, the output of the *luminaire* can be taken as the basis (the 100%) and the flux fractions can be defined as UFF upward and DFF downward, defining the flux fraction ratio (FFR):

$$\text{FFR} = \frac{\text{UFF}}{\text{DFF}}$$











E.g. continuing the above example:

	lm		%
Luminaire output	800		100
– Upward flux	300	UFF	37.5
– Downward flux	500	DFF	62.5

$$\text{FFR} = 37.5/62.5 = 0.6 \text{ (the same ratio is given by the above ULOR/DLOR} = 30/50 = 0.6).$$

Fig. 2.47 shows some general descriptive terms used for luminaires and symbols used for these on plans.

A more precise definition of a lamp/luminaire combination (or a lamp acting as a luminaire) is given by the *polar curves* (or polar intensity diagrams). For luminaires of a rotational shape (symmetrical about any vertical plane laid across the axis of the luminaire)

Symbol	Designation	Principle	UFF (%)	DFF (%)
	Direct		0–10	100–90
	Semi-direct		10–40	90–60
	General diffusing		40–60	60–40
	Semi-indirect		60–90	40–10
	Indirect		90–100	10–0

**Fig. 2.47**  
Luminaire types and their flux fractions.



a semicircular polar diagram is used on which the source intensity (cd) viewed from different directions (view angles) is plotted (Fig. 2.48). For elongated luminaires two such semicircles are put together, the left side for the cross-section and the right side showing the distribution lengthwise (along the longitudinal vertical plane) (Fig. 2.49).

For a lamp alone or for a luminaire with a specified lamp the polar curves give the actual source intensity values. Where the same luminaire can be used with a range of different lamps (e.g. different fluorescent tubes) the polar curves would give the values per 1000 lm lamp output, which then has to be adjusted for the lumen output of the lamp used. Data sheet D.2.8 shows polar curves for some typical luminaires/lamps.

**Example 2.2**

From the polar curve (Fig. 2.49) the source intensity at 20° view angle is read as 1950 cd (interpolated between the 1800 and 2100 cd arcs). If a ‘warm white’ lamp is used which gives an output of 2700 lm, the intensity has to be adjusted as

$$I_{20} = 1950 \times \frac{2700}{1000} = 5265 \text{ cd,}$$

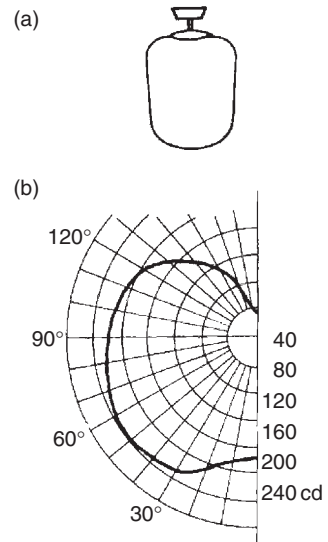
but if it is used with a ‘Kolor-rite’ tube, which has an output of 1800 lm, then

$$I_{20} = 1950 \times \frac{1800}{1000} = 3510 \text{ cd.}$$

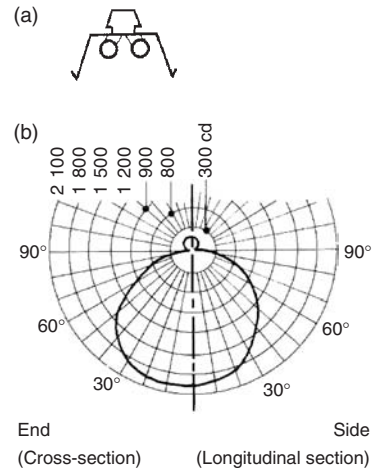
In the last 20 years, or so, a series of *compact fluorescent lamps* became available (Fig. 2.50). These fit into ordinary BC or ES lamp holders and can now be inserted into most luminaires originally designed for incandescent lamps. Their luminous efficacy is some five times that of incandescent lamps, e.g. the same flux output is obtained from compact fluorescent as incandescent

Compact fluorescent (W)	Incandescent (W)
10	50
15	75
18	90

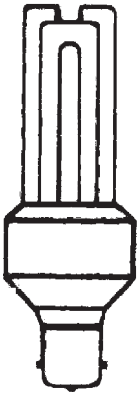
With these all the control gear (starter, choke, power factor corrector) are incorporated in the base of the lamp. Lamp life is claimed to be some eight times that of incandescent lamps, some 8000 h. The use of such compact fluorescent lamps (instead of incandescent) can result in energy savings up to 80%, thus it is an important contribution to sustainability.



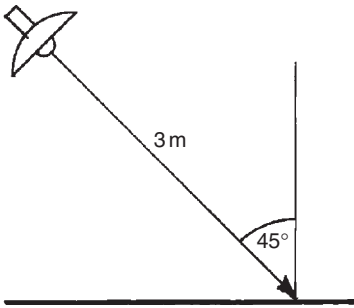
**Fig. 2.48**  
A diffuser luminaire and its polar curve.



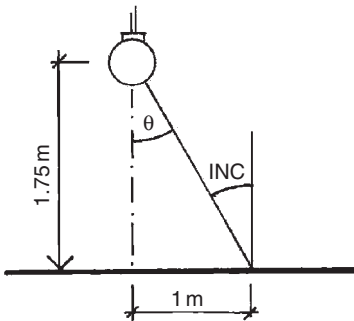
**Fig. 2.49**  
An open trough luminaire and its polar curves.



**Fig. 2.50**  
A compact fluorescent lamp.



**Fig. 2.51**  
Spotlight on a horizontal surface (Example 2.3).



**Fig. 2.52**  
Diffuser lighting a horizontal surface (Example 2.4).

### 2.5.3 Local lighting design

The quantitative design of local lighting from a single source is simply the application of the inverse square law (Eq. 2.3), corrected by the cosine law for angle of incidence.

#### Example 2.3

For a spotlight aimed at a point on a horizontal surface (Fig. 2.51) we read the intensity of  $I = 3800$  cd along the axis of the lamp ( $0^\circ$  viewing angle) and if the angle of incidence is  $45^\circ$ , with a distance of 3 m we get an illuminance

$$E = \cos \text{INC} \times \frac{I}{d^2} = \cos 45^\circ \times \frac{3800}{3^2} = 299 \text{ lx.}$$

#### Example 2.4

An opal diffuser luminaire is mounted at 1.75 m above the work plane, with its axis vertical and the illuminance at 1 m to one side of the aiming point is to be found (Fig. 2.52) First find the viewing angle:

$$\theta = \arctan \frac{1}{1.75} = 30^\circ, \text{ the geometry is such that } \text{INC} = \theta$$

and the distance is  $d = \sqrt{1^2 + 1.75^2} = 2$  m.

From the polar curve (Fig. 2.48), the source intensity is found as  $I_{30} = 230$  cd

$$E = \cos 30 \times \frac{230}{2^2} = 50 \text{ lx.}$$

For a linear source of light (of 'infinite' length), the illuminance is proportional to the distance, so instead of the inverse square law, we have the inverse distance law:  $E = I/d$ .

#### Example 2.5

We have a notice board illuminated by a row of tubular lamps from a distance of 2.5 m, which is continuous beyond the edges of the board by the same length as the distance of 2.5 m (thus it can be considered as 'infinite'). The source intensity is read as 150 cd, corrected for a warm white lamp:

$$I = 150 \times \frac{3800}{1000} = 570 \text{ cd}$$

At a point on the board where the angle of incidence is  $30^\circ$ , the illuminance will be

$$E = \cos 30 \times \frac{570}{2.5} = 197 \text{ lx.}$$

If two or more lamps/luminaires contribute to the lighting of a point, the illuminance from each has to be calculated and these illuminances are simply additive. This is the basis of the *point-by-point method* of lighting design. This is quite simple and manageable for one or two lamps contributing to the lighting of (say) a notice board, but if we have a large room (e.g. an office or a classroom) with many light sources, calculations for the whole work plane become cumbersome. However, the method can provide the algorithm for a computer program.

For general lighting, a rough estimate can be produced by the *watt method*. This is based on a table (such as Table 2.6), which gives the lamp power requirement (W) per unit floor area, per lux illuminance required.

#### Example 2.6

Given: a large general office of  $120 \text{ m}^2$ . From D.2.6 the required illuminance is  $500 \text{ lx}$ . We choose fluorescent white lamps in enclosed diffuser luminaires. The total wattage of the lighting will be  $120 \times 500 \times 0.050 = 3000 \text{ W}$

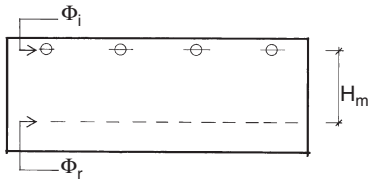
The alternative is to use the lumen method of general lighting design.

### 2.5.4 The lumen method

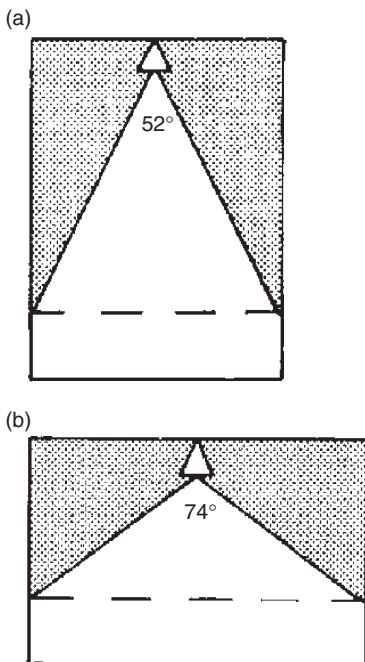
The lumen method (or total flux method) of general lighting design is applicable where a regular array of luminaires produces a uniform lighting over the work plane. The criterion for uniformity

**Table 2.6** Lamp power required

Lamp type		W/( $\text{m}^2\text{lx}$ )
Incandescent	Open enamelled reflector	0.150
	General diffusing	0.175
Mercury	Industrial reflector	0.065
	Open trough	0.040
Fluorescent, white	Enclosed diffusing	0.050
	Louvred, recessed	0.055
	Enclosed diffusing	0.080
Fluorescent, de luxe warm white	Enclosed diffusing	0.080
	Louvred, recessed	0.090



**Fig. 2.53**  
Interpretation of flux installed and flux received.



**Fig. 2.54**  
Interpretation of the direct ratio.  
a)  $52^\circ/180^\circ = 0.29$  (29%)  
b)  $74^\circ/180^\circ = 0.41$  (41%)

is that at the point of least illuminance it is not less than 70% of the maximum. In practice, this is provided by limiting the spacing of luminaires to 1.5 times the height of luminaires from the work plane, i.e. the mounting height ( $H_m$ ).

The total lumen output of lamps is calculated for a given system, which is referred to as the *installed flux* ( $\Phi_i$ ) and the *flux received* on the work plane will be (Fig. 2.53)

$$\Phi_r = \Phi_i \times UF \times MF, \text{ then the illuminance is } E = \frac{\Phi_r}{A},$$

where MF is the maintenance factor, to allow for the deterioration of the lamp, luminaire and room surfaces. In the absence of more accurate data, this is taken as 0.8. UF is the utilisation factor and the method hinges on finding the appropriate UF value.

The magnitude of UF depends on the following factors:

1. **Properties of the luminaire:** an enclosed luminaire or one with less than perfect internal reflectance will have a value much lower than an exposed lamp.
2. The downward light output ratio (**DLOR**) of the luminaire. Light emitted upwards will reach the work plane only after reflection(s) from room surfaces and some of it is absorbed in these surfaces. A larger DLOR normally means a higher UF.
3. **Reflectance of room surfaces**, which is more important if the DLOR is smaller, influence the lighting even with high DLOR values.
4. **Geometrical proportions of the room**, as expressed by the room index, the ratio of horizontal areas:  $L \times W \times 2$  and vertical areas  $(L + W) \times 2 \times H_m$ , where  $H_m$  is the mounting height, from the work plane to the luminaire (the multiplier 2 cancels out)

$$RI = \frac{L \times W}{(L + W) \times H_m}.$$

5. **Direct ratio:** how much of the downward emitted light reaches the work plane directly (Fig. 2.54). This has a low value with a narrow and high room (small room index), but a high value for a wide room (large RI) and 'downlighter' type luminaires.

Data sheet D.2.7 gives the UF values for some typical luminaires with specified DLOR, for various room reflectances and room indices. Most catalogues of luminaires would give similar tables.

If an installation is to be designed, the above equations are inverted:

- if an illuminance  $E$  is required, this is multiplied by the work plane area to get the flux *to be received*,  $\Phi_r$
- the type of luminaire is selected and the UF is found
- the MF is taken as 0.8 (higher in very clean spaces, lower in dusty or dirty situations, or in the absence of regular cleaning)

- thus the flux *to be installed* will be

$$\Phi_i = \frac{\Phi_r}{UF \times MF}$$

Combining these steps, we have a single expression

$$\Phi_i = \frac{E \times A}{UF \times MF} \quad (2.14)$$

Then we have to work back, divide the  $\Phi_i$  by the output of one lamp to get the number of lamps required, decide whether single or double lamp luminaire would be used, devise a luminaire layout (a ceiling plan) and check the spacing limits.

### Example 2.7

A general office space is 12 m × 9 m and 2.7 m high. The illuminance required (from D.2.6) is 400 lx. Reflectances are: ceiling 0.7, walls 0.5. If the work plane is at 0.8 m and ceiling-mounted luminaires are to be used, then  $H_m = 2.7 - 0.8 = 1.9$  m. Therefore, the room index will be

$$RI = \frac{12 \times 9}{(12 + 9) \times 1.9} = \frac{108}{39.9} = 2.7$$

We select an enclosed plastic diffuser type luminaire, which has a DLOR of 0.5. In D.2.8 we locate the column headed  $\rho$  ceiling 0.7 and within this the subheading for  $\rho$  walls 0.5. There are lines for RI 2.5 and 3, so we make a note of both UF values of 0.55 and 0.58 and interpolate:

$$\frac{0.58 - 0.55}{3 - 2.5} \times 0.2 = 0.012,$$

which is to be added to the lower value. Thus,

$$UF = 0.56 \text{ (two decimal precision is quite sufficient).}$$

From Eq. 2.14 the flux to be installed is

$$\Phi_i = \frac{400 \times 12 \times 9}{0.56 \times 0.8} = 96\,429 \text{ lm.}$$

For uniformity, the spacing limit is  $1.5 \times 1.9 = 2.85$  m.

From D.2.9 we see that 1200 mm fluorescent lamps are available from 1120 to 2800 lm output and select a medium quality for good colour rendering: the Kolor-rite lamp with a flux output of 1800 lm. Of these, we may need  $96\,429/1800 = 54$  lamps. We can have twin-tube luminaires, so we need 27

of these. We may have 7 rows of 4 luminaires, so the spacing may be 1.7 m in the 12 m length (0.9 m from the walls) and in the 9 m width, the spacing would become 2.25 m (giving just over 1 m between ends of luminaires). Both are well within the 2.85 m limit.

### 2.5.5 Glare in artificially lit interiors

Glare, as a phenomenon affecting vision, has been discussed in Section 2.2.4. Whilst in daylighting/sunlighting it is difficult to quantify glare (although some quantitative methods exist) and it is best to tackle the problem in qualitative terms, in electric lighting all contributing factors are identifiable and controllable. For this the well-developed quantitative methods will be described in the present section. This approach is supported by the fact that under 'natural' lighting conditions, people seem to be more tolerant and adaptable, whilst in an artificially lit interior, glare is more readily noticed and not willingly tolerated.

A quantitative method is developed through the following reasoning:

1. Glare is a function of luminance ratios within the field of vision, but it is influenced by other factors

$$g = f \frac{L_1}{L_2} \quad (\text{where 'f' indicates 'function of ...'}),$$

where  $L_1$  is the higher luminance, of the potential glare source,  $L_2$  is the lower, the background luminance.

The coefficient  $f$  depends on several factors:

2. The size of the glare source, measured by the visual angle (solid angle) subtended by the source area,  $\omega$

$$\omega = \frac{\text{Area of glare source (m}^2\text{)}}{\text{Square of its distance (m}^2\text{)}}.$$

3. The position of the glare source, as measured by the position index ( $p$ ) derived from the horizontal ( $\phi$ ) and vertical ( $\theta$ ) angle of displacement from the line of vision

$$p(\phi, \theta)$$

so the above expression is empirically modified

$$g = \frac{L_1^a \omega^b}{L_2 p^c}$$

and values for the three exponents suggested by various researchers are

$$a = 1.6-2.2$$

$$b = 0.6-1.0$$

$$c = 1.6.$$

The Illuminating Engineering Society (IES, 1967) adopted the following expression for the *glare constant*:

$$g = \frac{L_1^{1.6} \omega^{0.8}}{L_2 p^{1.6}}. \quad (2.15)$$

In many situations where the observers' line of vision cannot be determined, the position index ( $p$ ) term can be omitted.

The 'glariness' of a given space can be expressed by the *glare index* (GI), after calculating the glare constant ( $g$ ) for each potential glare source:

$$GI = 10 \times \log_{10} \left( 0.478 \times \sum g \right).$$

The probable subjective responses to situations described by this glare index are

GI = 0–10: imperceptible

GI = 10–16: perceptible

GI = 16–22: acceptable

GI = 22–28: uncomfortable

GI > 28: intolerable

The least significant increment in GI is 3.

The acceptable level of glare depends on the visual task and on illuminance. Usually a more exacting task, the higher illuminance would attract a stricter glare limit. The recommended limits are:

GI = 25: for most industrial tasks

GI = 22: for fine industrial tasks

GI = 19: inspection and offices

GI = 16: drawing offices and classrooms

GI = 13: sewing

GI = 10: very small instruments

Data sheet D.2.6 gives the recommended glare index limits alongside the illuminance values. Method sheet M.2.3 gives details of the calculation method.

The glare index system described above was developed over the 1950s and found general acceptance after the 1967 IES publication Technical Report No. 10. In the USA several methods were in use: the *Visual Comfort Probability* (VCP) system and the *Discomfort Glare Rating* (DGR) method. The Cornell formula is in fact quite similar to Eq. 2.15 described earlier:

$$g = \frac{L_1^{1.6} \omega^{0.8}}{L_2 + 0.07 \times \omega^{0.5} \times L_1}.$$

The CIE is working to reconcile the British glare index method with the Scandinavian Einhorn formula and the American VCP system. Their current proposal for a Unified Glare Rating system is also similar to Eq. 2.15:

$$UGR = 8 \times \log \frac{0.25 \times L_1^2 \times \omega}{L_2 \times p^2}.$$

The Australian Standard 1680 uses a luminance limiting method. Tables are given for source surface luminance limits for various situations and for lengthwise and crosswise view of the luminaires between 1 and 16 kcd/m<sup>2</sup>. To avoid veiling reflections, Table 2.7 presents values from the Standard for the lowest limits for the E/L ratio:

$$\frac{E}{L} = \frac{\text{Task illuminance}}{\text{Source luminance}} = \frac{\text{lx}}{\text{kcd/m}^2}.$$

This is however a luminaire selection method rather than glare evaluation.

Total avoidance of glare is not always desirable. In some situations, monotony and uniformity can be relieved by a controlled amount of glare; it can create interest or 'sparkle'. Unscrupulous designers can use it to create striking psychological effects ('bedazzling' the viewer) such as an east facing (sunlit) altar window in an otherwise dark church or the use of exposed high brightness small (tungsten-halogen) spotlights with chrome-plated surfaces in a pop fashion boutique. (One academic

**Table 2.7** Minimum E/L ratios to limit veiling reflections

Light-coloured tasks with good contrast; only slightly glossy details e.g. pencil on white paper, as in offices or schools	80
Light-coloured tasks with good contrast, with an overall gloss e.g. pencil on coloured paper or tracing, reading glossy paper	160
Dark-coloured tasks with an overall gloss and light coloured tasks with poor contrast, e.g. glossy photos, half-tone on glossy paper	800



even created a mathematical expression – only half jokingly – for the ‘glitter quotient’.) The most extreme deliberate use of glare is in a dark night club, with glaring spot-lights, possibly with strobe lights, which produce an intoxicating, practically narcotic effect.

### 2.5.6 Integration/discussion

In side-lit rooms, the level of daylighting rapidly drops with the increase of distance from the window. It often happens that daylighting near the window is quite sufficient, but not at the back of the room. The rear part of the room could be used for storage (e.g. filing cabinets) or visually less demanding functions (e.g. tea-making) but work areas may still be left with inadequate daylight. Probably the full electric lighting system would be switched on. The energy conservation (thus sustainability) requirement would dictate that daylighting be used whenever and as far as possible.

A simple solution is to arrange the electric lighting in rows parallel with the window wall and switch these rows on only as and when necessary (Fig. 2.54). It is rare to find side-lit spaces where daylight alone would be sufficient beyond a depth of about 2.5 times the window head height (from the work plane). In this case there may be some permanent electric lighting at the rear of the room, hence the acronym PSALI (permanent supplementary artificial lighting of the interior).

It has been demonstrated that people prefer daylight to artificial light and they do like (perhaps even *need*) visual contact with the outside world and its continually changing lighting conditions. For all these reasons, the principles of PSALI have been established as

- (1) utilisation of daylight as far as practicable;
- (2) use of electric lighting to supplement the daylight in the interior parts of the room;
- (3) design of the lighting in such a way that the essentially daylight character of the room is retained.

The last of these principles sets a qualitative as well as a quantitative requirement. Warmer light (a lower CT) is acceptable with low levels of illuminance. Here it should be comparable to daylight, which is of a CT of 5000–6500°K. In situations where visual tasks are all-important (drawing offices, laboratories) for precision work and good colour rendering an ‘artificial daylight’ lamp (of 6500°K) is advisable. In less critical situations, a ‘cool white’ (of 4300°K) is acceptable.

The illuminance provided by the supplementary lighting should be comparable to the quantity of daylight available near the window, at the 2% DF contour. Above this there would be no supplementary lighting and below this we would attempt to bring the

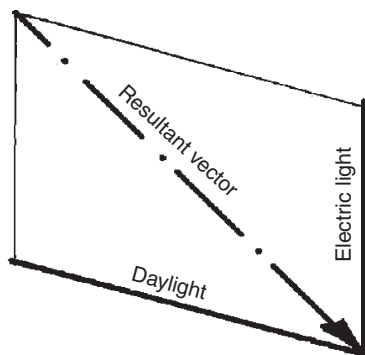
illuminance up by artificial light input. The magnitude of this can be estimated as follows:

- (1) determine the daylight zone, either as the 2% DF contour, or take the DF at 0.2H distance from the window and multiply this by 0.1 (where H is the window head height above the work plane);
- (2) find the average  $DF_{av}$  for the rest of the room;
- (3) the illuminance to be added to this area is  $E_{add} = 500 \times DF_{av}$ .

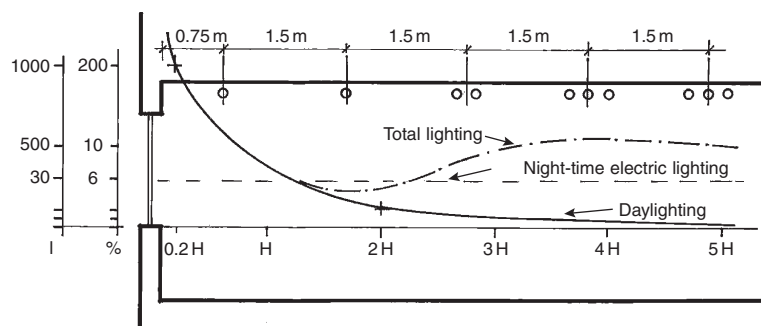
One additional benefit of PSALI is that of correcting the illuminance vector. It has been mentioned (in Section 2.32) and shown (in Fig. 2.15) that at some distance away from the window, the vector becomes near horizontal (whereas people's preference is for a vector altitude of at least 15–20°. Fig. 2.55 is a reminder for the addition of vectorial quantities and it can be seen that the near-vertical light from ceiling-mounted luminaires at the back of the room would increase the vector altitude.

Fig. 2.56 shows a practical arrangement in diagrammatic terms. The electric lighting luminaires are arranged (e.g.) in five rows. At night one lamp (or line of lamps) would operate in each row. During the day rows 1 and 2 would be switched OFF. Rows 3–5 would be switched ON. Daylight factor at 0.2H is 20%, 0.1 times this is 2%, which in this case is at 2H distance. For the rest of the room  $DF_{av}$  is about 1%.  $E_{add} = 500 \times 1 = 500 \text{ lx}$ . This is to be provided by three lamps, but in row 3 only by two lamps, as the DF here is about 1.5%, and to provide a smooth transition.

Integration of daylight control with the control of solar radiation input (for thermal reasons) is an important issue. This may be true in cool climates, where some passive solar heating system is used, which may create glary conditions, but especially so in a warm climate, where the shading system is often overdesigned to exclude solar heating (the designer may want to be 'on the safe side'). This is just as bad as inadequate shading. The room may



**Fig. 2.55**  
Addition of vectors (the parallelogram of vectors).



**Fig. 2.56**  
Switching arrangement in rows of luminaires, for PSALI.

become unduly dark and electric lighting may have to be used all day. This is not only wasting energy, but may also cause a significant addition to the thermal load. Unfortunately, very often the reason is the designer's lack of knowledge. Sustainability would demand that solar control be 'just right'.

If the orientation is correct and the window is facing the equator, it is easy to produce the right shading. With less than perfect orientation, often some degree of compromise is necessary. The designer has to consider a balance of benefits and disbenefits. What is worse: having an undesirable sun penetration for a short time or having overdesigned shading for the rest of the time?

Besides lighting and solar heat gain other issues may have to be included in the balance equation, such as the view out or the view in (privacy), or indeed the effect of such devices on natural ventilation. The designer should be able to quantify all terms of such an equation, but experience may develop a sense of magnitude of these factors and may aid in making reasoned judgements in qualitative terms, without meticulous (and lengthy) calculations in each instance.

# PART 3

## SOUND: THE SONIC ENVIRONMENT

<b>3.1 Physics of sound</b>	<b>145</b>	3.3.2 Control of environmental noise	165
3.1.1 Attributes of sound	145	3.3.3 Barriers and sound insulation	167
3.1.2 Pure tones and broad-band sound	146	3.3.3.1 Structure-borne sound insulation	169
3.1.3 Propagation of sound	147	3.3.4 Noise control by absorption	171
3.1.4 Acoustic quantities	149	<b>3.4 Room acoustics</b>	<b>176</b>
<b>3.2 Hearing</b>	<b>152</b>	3.4.1 Requirements	177
3.2.1 The audible range	152	3.4.2 Room size and shape	178
3.2.2 Noise: definition and rating	153	3.4.3 Room surfaces	180
3.2.3 Noise spectra	156	3.4.3.1 Acoustic quality	181
3.2.4 Noise climate	158	3.4.4 Electroacoustics	183
<b>3.3 Noise control</b>	<b>161</b>	3.4.4.1 Sound reinforcement	183
3.3.1 Sound transmission	161	3.4.4.2 Acoustic corrective systems	186
3.3.1.1 In a free field	161	3.4.4.3 Acoustic measurements	187
3.3.1.2 In buildings	162	3.4.5 Integration/discussion	188

## Symbols and Abbreviations

a	absorption coefficient	M	mass, surface density ( $\text{kg/m}^2$ )
f	frequency (Hz)	MCR	multi-channel reverberation
h	height	NC	noise criteria
p	sound pressure (Pa)	NNI	noise and number index
r	radius	NR	noise rating
s	surface area	P	sound power (W)
v	velocity	RT	reverberation time
$\alpha$	absorptance	S	stimulus or sound source
$\lambda$	wavelength	SIL	speech interference level
$\rho$	reflectance or density	SiL	sound intensity level
$\tau$	transmittance	SpL	sound pressure level
Abs	total absorption ( $\text{m}^2$ open window units)	SRI	sound reduction index
ARS	assisted resonance system	STC	sound transmission class
C	a constant	R	response
CRT	cathode ray tube	S	stimulus
DIN	Deutsche Institut für Normung	TL	transmission loss
I	intensity ( $\text{W/m}^2$ )	TNI	traffic noise index
L	sound level	V	volume or volt

### 3.1 Physics of sound

Sound is the sensation caused by a vibrating medium as it acts on the human ear. Loosely, the term is also applied to the vibration itself that causes this sensation. Acoustics (from the Greek ακουστικός) is the science of sound, of small amplitude mechanical vibrations.

A simple acoustic system consists of a source, some conveying medium and a receiver. The source is a vibrating body, which converts some other form of energy into vibration (e.g. mechanical impact on a solid body, air pressure acting on a column of air, such as in a whistle or pipe, electrical energy acting on a steel membrane or on a crystal, etc.). The word *transducer* is often used for devices converting other forms of energy into sound (e.g. a loudspeaker) or vice versa (e.g. a microphone). The conveying medium may be a gas (e.g. air), which transmits the vibration in the form of longitudinal waves (alternating compressions and rarifications), or a solid body, where lateral vibrations may also be involved (e.g. a string). Fig. 3.1 illustrates the longitudinal (compression) waves and their representation by a sine curve.

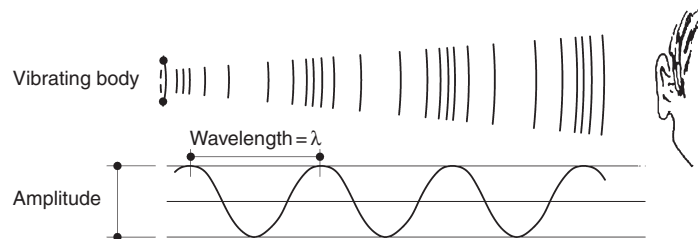
In buildings we are concerned with *airborne sound* or *structure-borne sound*, that are transmitted by the building fabric.

#### 3.1.1 Attributes of sound

Sounds are characterised by wavelength ( $\lambda$  in m) or frequency ( $f$  in Hz) and the product of the two, the velocity ( $v$  in m/s). The latter depends on the transmitting medium. In air it is usually taken as 340 m/s, but it varies with temperature and humidity (faster in warmer, less dense air).

The relevant equations are very similar to those given for light (Eq. 2.1):

$$v = f \times \lambda, \quad (3.1)$$



**Fig. 3.1**

Sound waves: longitudinal compression waves and their sinusoidal representation.

**Table 3.1** Sound power of some sources

Jet airliner	10 kW (10 <sup>4</sup> W)
Pneumatic riveter, accelerating motorcycle	1 W
50 kW (electrical) axial flow fan	0.1 W (10 <sup>-1</sup> W)
Large (symphonic) orchestra	0.01 W (10 <sup>-2</sup> W)
Food blender, coffee grinder	0.001 W (10 <sup>-3</sup> W)
Conversational speech	0.000 01 W (10 <sup>-5</sup> W)

from which

$$\lambda = \frac{340}{f} \quad \text{and} \quad f = \frac{340}{\lambda}.$$

The output (power, P) of a sound source is measured in watts (W). Table 3.1 gives some typical sound power values:

Frequency is perceived as pitch and the 'strength' of sound is measured either by its pressure, p (in Pa), or by its power density or intensity, I (in W/m<sup>2</sup>). The latter is the density of energy flow rate. Sound pressure actually varies within every cycle from zero to positive peak then through zero to a negative maximum, so what we measure is the root mean square (RMS) pressure.

The relationship of p and I depends on the conveying medium, but in air under 'standard conditions' (air density of  $\rho = 1.18 \text{ kg/m}^3$  and  $v = 340 \text{ m/s}$ ) it is usually taken as

$$p = 20\sqrt{I}. \quad (3.2)$$

note that p (lower case) denotes sound pressure, P (capital) denotes sound source power

### 3.1.2 Pure tones and broad-band sound

A sound that can be described by a smooth sine curve and is of one particular frequency is referred to as a *pure tone sound*. This can only be generated electronically. Sounds produced by instruments always contain some harmonics.

The fundamental frequency itself is the first harmonic. The second harmonic is double that frequency, the third is three times that, etc.; e.g. middle C has a frequency of 256 Hz. Its harmonics will be:

$$2\text{nd} = 512 \text{ Hz}$$

$$3\text{rd} = 768 \text{ Hz}$$

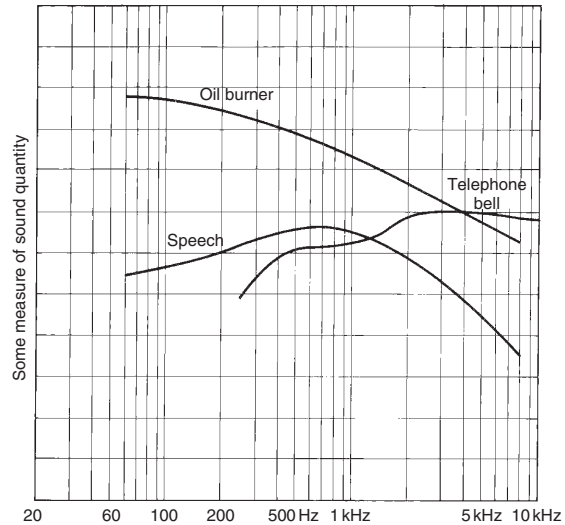
$$4\text{th} = 1024 \text{ Hz}$$

Most sounds contain many frequencies and are referred to as *broad-band sounds*. An octave extends from f to 2f frequency, e.g. from 1000 to 2000 Hz. An octave band is usually designated by its centre frequency ( $f_c$ ), then the limits are defined as

$$f_{\text{lower}} = f_c \times \frac{1}{\sqrt{2}} \quad \text{and} \quad f_{\text{upper}} = f_c \times \sqrt{2}.$$

**Table 3.2** Standard octaves (in Hz)

Centre	31.5	63	125	250	500	1000	2000	4000	8000	
Limits	22	44	88	177	354	707	1414	2828	5656	11312



**Fig. 3.2**  
Some typical sound spectra.

Table 3.2 shows the standard octave band centre frequencies and the octave boundaries.

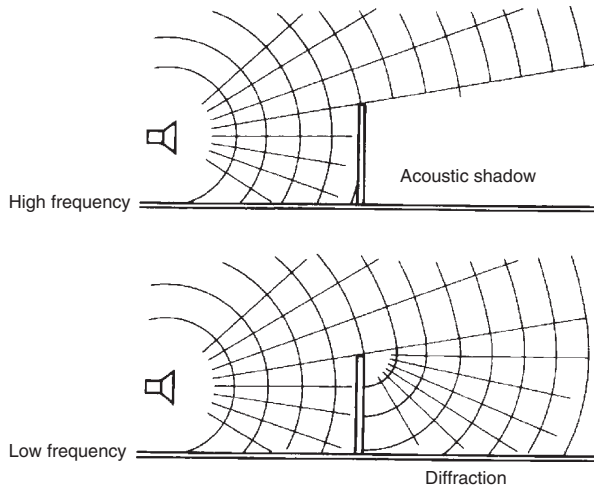
If the sound is measured in each octave separately (by using 'octave-band filters') then a sound spectrum can be built up, such as those shown in Fig. 3.2.

### 3.1.3 Propagation of sound

A sound field is the volume of space where vibrations emitted by a source are detectable. A *free-field* is one where the effects of boundaries are negligible, where there are no significant reflections. When a uniform point source emits a sound, this energy flow spreads in all radial directions, distributed over the surface of a sphere of increasing radius. As the surface of a sphere is  $4\pi r^2$ , the sound intensity (power density) at any distance  $r$  from the source will be

$$I = \frac{P}{4\pi r^2} \text{ (W/m}^2\text{)}. \quad (3.3)$$





**Fig. 3.3**  
Acoustic shadow and diffraction.

This is known as the inverse square law. Intensity is proportionate to the square of sound pressure and sound pressure reduces with the distance (and not with the square of distance), e.g.:  
if power,  $P = 10\text{ W}$

Distance at (m)	$I$ ( $\text{W}/\text{m}^2$ )	$p$ (Pa)
2	0.2	8.94
4	0.05	4.47
8	0.0125	2.236

In addition to such reduction with distance, there will be some molecular absorption of energy in air, which is hardly noticeable at low frequencies (up to about 1000 Hz) but quite substantial at high frequencies (e.g. at 8 kHz, over a 300 m distance, it would be a reduction of  $10^{-4}\text{ W}/\text{m}^2$ ). See also D.3.2.

When a wavefront reaches an obstacle (e.g. a wall or a screen) the original pattern of waves continues above the top of this obstacle, but it will create an *acoustic shadow*. This may be quite clearly defined for a very high frequency sound (similar to light shadow), but at low frequencies diffraction occurs at the edge of the obstacle, and that edge behaves as a virtual source, as shown by Fig. 3.3.

If two sources contribute to the sound field, the intensities are additive, but for pressure the squares of the contributing pressures must be added and the result will be the square root of this sum.

$$I = I_1 + I_2, \quad \text{e.g. } I = 0.05 + 0.0125 = 0.0625 \text{ W/m}^2,$$

but

$$p = \sqrt{p_1^2 + p_2^2}, \quad \text{e.g. } p = \sqrt{4.47^2 + 2.236^2} = 5 \text{ Pa.}$$

$$\text{Check (from Eq. 3.2): } p = 20\sqrt{0.0625} = 5 \text{ Pa.}$$

### 3.1.4 Acoustic quantities

Fechner's law suggests that human response to a stimulus is logarithmic; in general terms

$$R = C \times \log S$$

where  $R$  = response,  $C$  = a constant,  $S$  = stimulus (log is to base 10).

Intensity and pressure are measures of the stimulus. At low intensities we can distinguish quite small differences, but the ear's sensitivity reduces with higher intensities. As a first approximation of auditory response, a logarithmic scale has been devised: the *sound level*.

The logarithm of the ratio  $I/I_0$  has been named Bel (after Alexander Graham Bell), but as this is a rather large unit, its sub-multiple, the deci-Bel (dB), is used.

It can be derived from intensity or from pressure:

$$\text{Sound intensity level: } \text{SiL} = 10 \times \log \frac{I}{I_0} \quad (3.4)$$

$$\text{Sound pressure level: } \text{SpL} = 20 \times \log \frac{p}{p_0} \quad (3.5)$$

and the reference values have been standardised as the average threshold of audibility:

$$I_0 = 1 \text{ pW/m}^2 \quad (\text{pico-Watt} = 10^{-12} \text{ W})$$

$$p_0 = 20 \text{ } \mu\text{Pa} \quad (\text{micro-Pascal} = 10^{-6} \text{ Pa})$$

Under standard atmospheric conditions, both derivations give the same result, so in practice both may be referred to as sound level (L).

The intensities of two sounds are additive, but not the corresponding sound levels. If sound levels are given, they must be converted to intensities, these intensities can be added, then the resulting sound level must be found.

**Example 3.1**

Two sound levels are given:  $L' = 90$  dB,  $L'' = 80$  dB. The sum of the two is NOT 170 dB (!)

From Eq. 3.4:  $I = 10^{(L/10-12)}$ .

Thus,

$$I' = 10^{(9-12)} = 10^{-3} = 0.001,$$

$$I'' = 10^{(8-12)} = 10^{-4} = 0.0001,$$

$$I' + I'' = 0.0011 \text{ W/m}^2$$

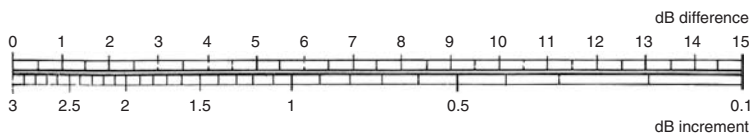
$$L_{\text{sum}} = 10 \log \frac{0.0011}{10^{-12}} = 10 \log(11 \times 10^8) = 10 \times 9.04 = 90.4 \text{ dB.}$$

To continue the above example: the difference is  $90 - 80 = 10$  dB. On the nomogram (Fig. 3.4), opposite 10 dB reads 0.4, so the sum will be  $90 + 0.4 = 90.4$ .

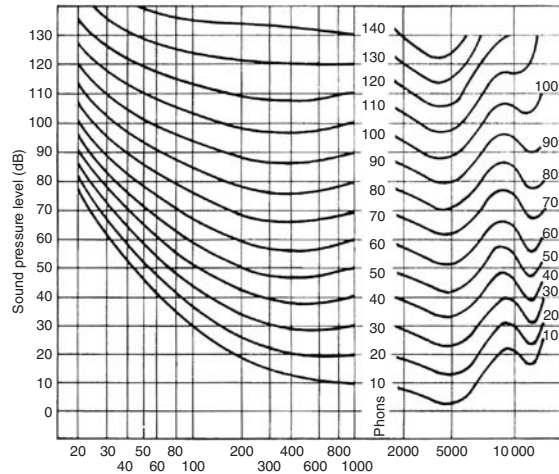
The next step in quantifying the auditory response recognises that the sensitivity of the ear varies with the frequency of the sound. It is most sensitive to about 4 kHz (4000 Hz). Sensitivity to various pure tone sounds has been plotted on a (logarithmic) frequency graph, giving the *equal loudness contours* (Fig. 3.5). These curves are designated by the sound level at 1 kHz and define the loudness level (phon) scale (i.e. the sound level and loudness level scales coincide at 1 kHz frequency).

E.g. take the 30 phon curve. This indicates that at 1 kHz a sound level of 30 dB is perceived as 30 phon loudness level, but 30 dB at 100 Hz would only give 10 phon, whilst at 4 kHz it is perceived to be about 37 phon loudness level. Conversely, 40 phon loudness level is produced by (e.g.) each of the following sounds:

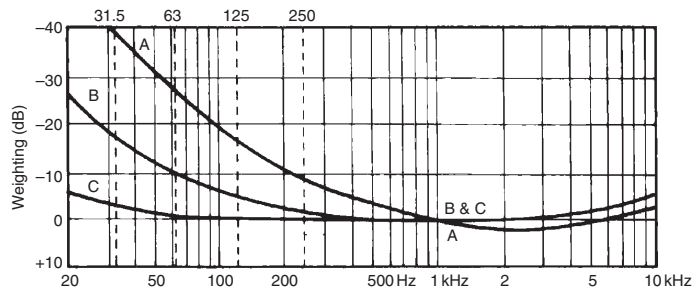
At 40 Hz ...	70 dB
At 100 Hz ...	52 dB
At 250 or 1000 Hz or 5500 Hz ...	40 dB
At 4000 Hz ...	32 dB



**Fig. 3.4** Nomogram for adding two sound levels. Find the difference between the two levels on the upper scale, note the value opposite (on the lower scale) and add this to the larger of the two levels given.



**Fig. 3.5**  
Equal loudness contours: definition of the phon scale.



**Fig. 3.6**  
Weightings of sound levels: A, B and C. Note that the A curve resembles the equal loudness (phon) contours, whilst the C weighting is almost linear.

i.e. all sounds along one of these equal loudness contours would be perceived to be of the same loudness level.

A true measure of the human ear’s sensitivity is thus found, after two adjustments:

- 1 for logarithmic response to the stimulus, which gave the sound level scale (dB)
- 2 for the frequency dependence of our ear, which gave the loudness level (phon).

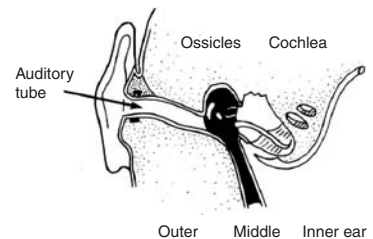
Phon cannot be measured directly, but an electronic weighting network provides an approximation. The effect of ‘A’ weighting is shown in Fig. 3.6. Sound levels measured with this weighting are referred to as dBA. (The German DIN Standards refer to such a

weighted scale as ‘instrument phon’.) Other weighting scales also exist, but are of no great relevance to architecture. These dBA values are often used to describe a broad-band sound with a single figure index. However, numerous combinations of levels and frequencies may give the same dBA value. Thus, an accurate description of a broad-band sound can only be given by its spectrum.

## 3.2 Hearing

Aural perception (from the Latin *auris* = ear) starts with the ear. Airborne sounds reach the ear-drum through the auditory tube and it will start vibrating (Fig. 3.7). This vibration is then transmitted by the ossicles (hammer, anvil and stirrup) to the inner membrane of the oval window and through this it reaches the inner ear, the cochlea. Some 25 000 hair-like endings of the auditory nerve are located in the cochlea, which selectively respond to various frequencies and generate nerve impulses, subsequently transmitted to the brain.

These impulses are interpreted by the brain, but the first selection takes place in the inner ear. The ear is thus not only a very efficient microphone but also an analyser. Most of the auditory brain functions involve pattern recognitions, filtering out what is relevant, and interpretation, based on memory, i.e. past experience.

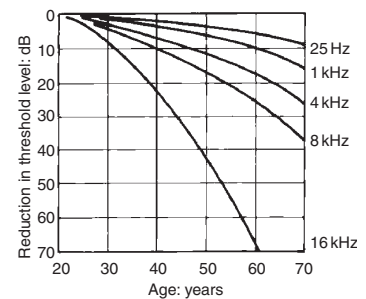


**Fig. 3.7**  
The human ear.

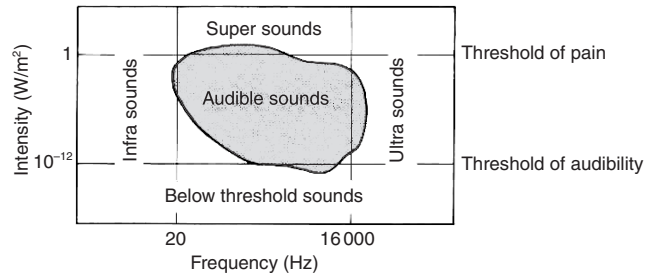
### 3.2.1 The audible range

The human ear is sensitive to vibrations between 20 Hz and 16 kHz, but these limits also depend on the ‘strength’ of the sound. The audible range of frequencies may also be reduced (especially at high frequencies) by the listener’s state of health and definitely by old age. Fig. 3.8 shows that at age 60 people can expect to have a hearing loss of 70 dB at 16 kHz, but only a loss of about 10 dB at 1 kHz.

Fig. 3.9 illustrates the range of audible sounds, both in terms of frequency and ‘strength’. Strength is measured by three scales: pressure, intensity and sound level. Note that the top and bottom part of the outline corresponds to the equal loudness contours (at 0 and 120 phon). It also shows that there are vibrations below and above the limits: referred to as *infra-sounds* and *ultra-sounds* (infrasonic and ultrasonic vibrations). The bottom of the audible area is the *threshold of audibility* and the top is the *threshold of pain*. Above the latter there may be super-sounds, but there is no specific term for the below threshold sounds. (For calculation purposes both thresholds are fixed in terms of intensity, pressure or sound level, regardless of frequency.)

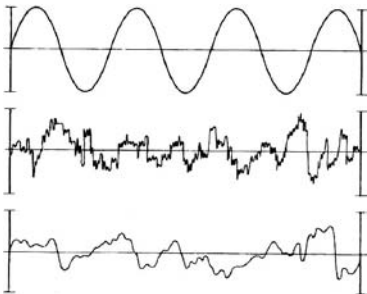


**Fig. 3.8**  
Presbycusis: loss of hearing with age.



**Fig. 3.9**  
The range of audible sounds.

If pitch is the subjective interpretation of the frequency of a sound, it clearly relates to pure tone (or near pure-tone) sounds. Complex sounds are physically determined by their spectrum, whilst the subjective term for the 'colouring' of a sound of a certain pitch is 'timbre' several everyday expressions can relate to certain types of sound, e.g. Fig. 3.10 shows a pure tone, a hissing sound and a rumble. The hiss is due to the many high frequency overtones, as shown by the middle curve.



**Fig. 3.10**  
Oscilloscope image of pure tone, a hiss and a rumble.

### 3.2.2 Noise: definition and rating

An attempted definition of noise in objective terms is 'random vibrations, showing no regular pattern'. However, noise is a subjective phenomenon, one person's enjoyable sound may be another's noise. The only meaningful definition of noise is therefore 'unwanted sound'. This is similar to the definition in telecommunications, where the *signal* is distinguished from the *noise*, which is all else.

The term *white noise* is used for a set of vibrations which contains equal amounts of energy in all wavelengths (*per analogiam*: white light, which includes all visible wavelengths of light). It is a common fallacy to believe that white noise would eliminate or suppress noise: it only reduces the intelligibility of such unwanted sound (if it has some information content).

In broad terms, the following noise effects can be distinguished:

65 dBA: up to this level, noise or unwanted sound may create annoyance, but the result is only psychological (nervous effects). Above this level, physiological effects, such as mental and bodily fatigue may occur

90 dBA: many years of exposure to such noise levels would normally cause some permanent hearing loss

100 dBA: with short periods of exposure to noise of such a level the aural acuity may be temporarily impaired (TTS, temporary threshold shift) and prolonged exposure is likely to cause irreparable damage to the auditory organs

120 dBA: is painful

150 dBA: causes instantaneous loss of hearing.

In more precise terms the spectral composition of the noise must also be taken into account. As opposed to the above 90 dBA limit, 'safe' levels of continued occupational noise exposure can be specified for each octave band:

Centre frequency:	63	125	250	500	1000	2000	4000	8000	Hz
Maximum level:	103	96	91	87	85	83	81	79	dB

The level of acceptable noise depends not only on objective, physical factors, but also on subjective, psychological ones. It depends on the state of mind and expectations of the listener. In a sleeper train the monotonous noise of 65–70 dBA does not disturb, but in a quiet home for a person 'badly tuned' the ticking of an alarm clock at 25 dBA can keep him (her) awake and cause annoyance.

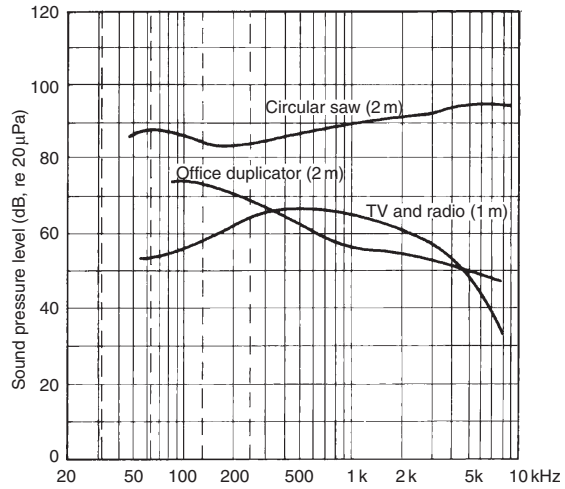
Noise may adversely affect concentration, particularly if the noise has an information content. In a work situation switching of the worker's attention from task to noise and back may take several seconds, and would affect work performance. The most obvious effect of noise is its interference with aural communication. This will be discussed in some detail in Section 3.3.

A pure tone sound can be described and quantified using the phon scale, but this is only possible if both its level (dB) and its frequency are known. A complex sound can be described in terms of its A-weighted sound level (dBA) but this is only a sketchy description. For a complete picture, an octave-band analysis (for more precision: a third-octave analysis) is necessary, which would produce its spectrum. Fig. 3.11 shows the spectra of noises produced by some everyday sources.

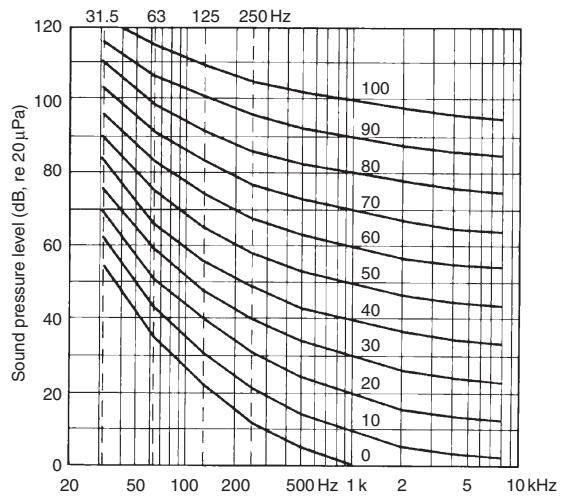
A single-figure description of such broad-band noises is available in terms of their *noise rating* (NR). A family of curves (the NR curves, Fig. 3.12) (or in the USA the very similar 'noise criteria', NC curves, which are still used there) must be laid over the noise spectrum, and the curve which just touches the spectrum at its (relatively) highest point gives the rating of that noise. Fig. 3.13 indicates that a high frequency noise has a greater effect on NR than one which has a dominantly low-frequency spectrum.

Subjective assessment of the noisiness of a given situation is closely related to its NR number. Generally people judge the situation as

NR20–25	Very quiet
NR30–35	Quiet
NR40–45	Moderately noisy
NR50–55	Noisy
NR60 and over	Very noisy



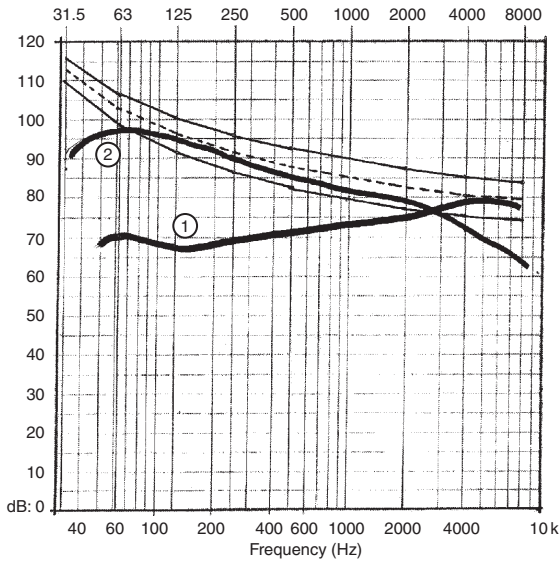
**Fig. 3.11**  
Noise spectra from some typical sources.



**Fig. 3.12**  
The noise rating (NR) curves.

There is no precise conversion of NR to dBA (or vice versa) as it depends on the spectrum. Whilst dBA is a weighted average, the NR is an upper limit of the spectrum. However, generally





**Fig. 3.13**  
 Rating of a high and a low frequency noise. NR80 and NR90 curves,  
 with NR85 dotted  
 1 – circular saw (16 m) touches NR85 at 5000 Hz  
 2 – heavy road traffic touches NR84 at 125 and 250 Hz  
 (10 m from road centre)

(and roughly) it can be taken as  $dB A = NR + 10$ . However, if a measurement is taken in  $dB A$ , it can be converted as  $NR = dB A - 5$ .

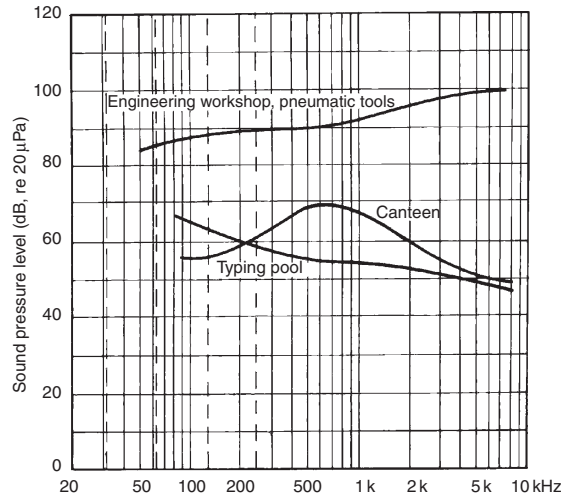
Whilst the NR number can be used to describe the noisiness of a situation, it can also be used as a criterion, to specify the acceptable noise level in a space, as a specification item given in a brief for a building design. For some common room uses, the following criteria are recommended:

Studio, concert hall	NR15
Lecture theatre, court room, church	NR25
Shops and stores	NR35–50

(See also data sheet D.3.1.)

### 3.2.3 Noise spectra

In a building interior (a closed field) with many sources of little directional tendencies, with multiple reflections, the sound



**Fig. 3.14**  
Noise spectra in some indoor environments.

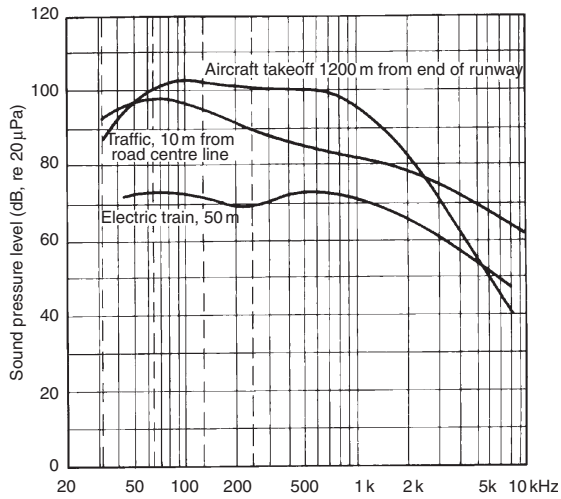
field would be fairly uniform and either a dBA value or an NR number would give a reasonable indication of the sonic environment. Fig. 3.14 shows a typical noise spectra of some indoor environments.

Under open-air conditions, in a free field, there being no reflections, the sound decreases with distance from the source. Any measurement must relate to a specified point, i.e. distance and direction from the source or notional location of the source. E.g. for traffic noise the centreline of the road is often taken as a linear source of noise. Fig. 3.15 presents the spectra of some typical outdoor noises, as measured at the stated distance from the source.

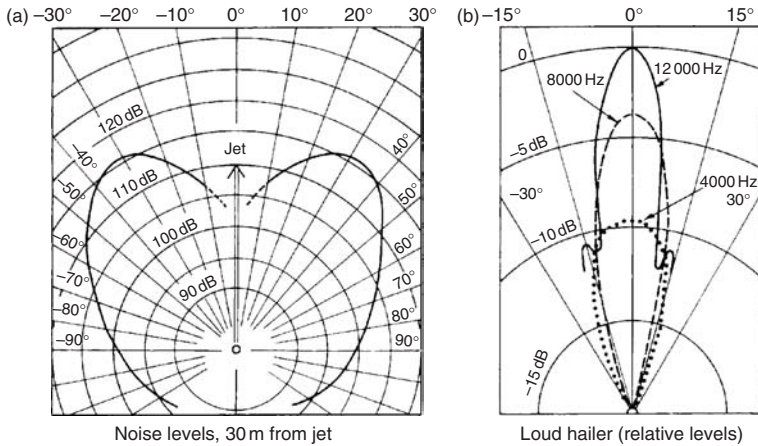
Whilst some sources emit sound fairly uniformly in all directions, others have strong directional tendencies. In a free field such directional tendencies must be ascertained and can be depicted in the form of polar curves (somewhat similar to the luminous intensity polar curves used for the light emission of luminaires, see Section 2.5.2).

Fig. 3.16 shows two forms of representation: (a) dB values in different directions from the source (relative to a stated axis) at some stated distance and (b) the relative reduction in dB at different directions from the peak value along the directional axis.

It is noticeable on the second of these, that high frequency sounds have much stronger directionality than those of low frequency (as mentioned in connection with barriers and shown in Fig. 3.3).



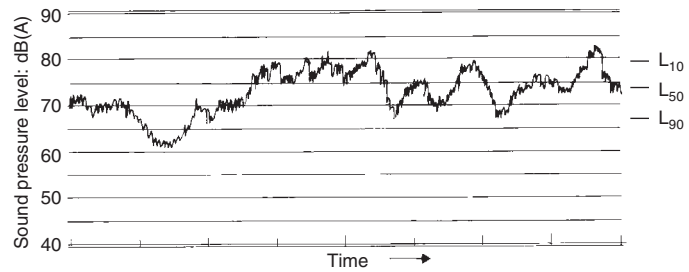
**Fig. 3.15**  
Spectra of some typical outdoor noises.



**Fig. 3.16**  
Directionality of some sources. (a) Noise levels, 30 m from jet and (b) Loud hailer (relative levels).

### 3.2.4 Noise climate

All the measures and discussions so far are related to an instantaneous noise condition, as it were giving only 'snapshots'. If variation in time is to be considered, we need to record the noise. A sample



**Fig. 3.17**  
A graphic sound level recording, showing  $L_{10}$ ,  $L_{50}$  and  $L_{90}$ .

of such graphic recording is shown in Fig. 3.17. Such a recording is usually taken in dBA, to bring different frequencies to a common denominator, but this way any indication of frequency is lost. It will be useful to characterise a noise climate where the spectral composition of noise does not vary significantly (e.g. traffic noise).

Even if such a recording is maintained for only 24 h it will be necessary to use statistical methods to obtain any meaning from it. A frequency distribution diagram (e.g. a bell curve) can be produced and various percentile values of the sound level calculated. Fig. 3.17 shows the following:

$L_{10}$ : the sound level exceeded 10% of time, i.e. in statistical terms the 90th percentile level, an indication of peak values

$L_{50}$ : the 50th percentile level, which is the median value for the measurement period

$L_{90}$ : the value exceeded 90% of the time, or the 10th percentile sound level, which can be taken as the average background sound level.

Modern instruments can produce such analyses automatically. Both the sampling interval (e.g. 1 s) and the 'bin width' can be set (e.g. counting the number of occurrences in 5 dB wide bands, and putting the measured values in 5 dB wide 'bins').

Such statistical analyses can form the bases of various measures to describe a noise climate. These can be of two kinds:

- (a) *Indices*, i.e. measures with a physical basis, on which other factors may be imposed, usually arrived at by social science (survey) methods.
- (b) *Scales*, in which various physical factors affecting people's responses are combined over a period of time. Examples of these are the equivalent sound level or mean energy level, the effective perceived noise level and the weighted equivalent continuous perceived noise level.

Such noise climate scales are beyond the scope of this work, but two often used indices are introduced:

The *traffic noise index* (TNI) is an empirical expression of the 24-h noise climate in a given situation, where the main contributor is road traffic. It is based on the above  $L_{10}$ ,  $L_{50}$  and  $L_{90}$  values:

$$\text{TNI} = 4 (L_{10} - L_{90}) + L_{90} - 30. \quad (3.6)$$

This has been found to give the best correlation with the nuisance effect of traffic noise. Some British legislation uses a similar derivation based on only 18 h recording of the noise climate (excluding the 6 h of the night).

Several studies have shown that traffic noise is the most intrusive and most often complained about source of annoyance, but closely followed by aircraft noise in areas around an airport. Here the influencing factor is not only the noise generated by each flight, but also the frequency or the number of flights. Thus, the *noise and number index* (NNI) has been devised, which is based on recordings between 6:00 and 18:00 h, where the contributing factors are the number of flights (N) and the peak noise level produced by each flight. It uses the PNdB (perceived noise level) scale and the empirical expression provides the best correlation with the disturbance effect ascertained by social survey methods.

Community noise is a generic term, which includes the above traffic and aircraft noise, but also industrial noise and 'neighbourhood noise' (from lawn mowers to parties, the neighbour's TV, construction work to air conditioning or ventilation noises) – in fact any noise that may exist in a given environment. Different criteria will apply as these noises affect

- (a) people in their homes, infringing their aural privacy
- (b) people in work situations
- (c) people in public spaces.

The effect of such noise depends very much on people's expectations: those directly involved with a particular noise may hardly notice it, may even enjoy it (e.g. a football crowd or a noisy party) whilst others may be greatly annoyed. The great complexity of the problem makes legislative controls difficult. Consideration of other people, reasonableness and common sense would probably be a better solution than legal control. Unfortunately, 'common sense' is a very rare commodity.

People in their homes would have the lowest annoyance threshold. As a general guidance, the following  $L_{10}$  (90th percentile) noise levels should not be exceeded inside any residential unit (Table 3.3).

**Table 3.3** Limits of community noise in residences

	Day (in dBA)	Night (in dBA)
Country areas	40	30
Saburban areas	45	35
Inner city areas	50	35

### 3.3 Noise control

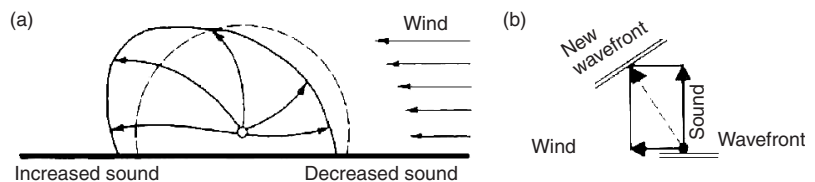
#### 3.3.1 Sound transmission

Sound is transmitted by a medium, which can vibrate: most often we are concerned with airborne sound, but it can also be transmitted by liquids or solids.

**3.3.1.1 In a free field** sound is reducing with the square of distance, from the source. This means that for every doubling of distance, the sound level is reduced by 6 dB (if intensity is reduced by a factor of 4, then  $L = 10 \times \log 4 = 6$  dB). The additional molecular absorption in air at high frequencies is shown in data sheet D.3.2. Such molecular absorption will change the sound spectrum, by filtering out the higher frequency components (e.g. whilst nearby thunder has a 'clang', from a greater distance it sounds more as a rumble).

*Ground cover*, over which the sound travels, may cause a surface friction, thus reducing the sound, which is noticeable if both source and the receiver are near ground level. Paved surfaces give no such reduction, but the effect of tall grass, shrubs and trees can be quite significant, as indicated by the table given in D.3.2.

*Wind* reduces sound upwind from the source and increases it downwind, not only because of the velocity effect, but due also to the distortion of the spherical wavefront. In Fig. 3.18 the arrows show the hypothetical 'sound rays' as they are deflected. The small vector diagram is an enlargement of the top of a wavefront.



**Fig. 3.18**  
The effect of wind on a sound wavefront.

The result of this is that some sound which would in still air travel upwards, is deflected and reinforces the sound at ground level.

Temperature gradients also have an effect. During the day, as the temperature near the ground is higher, sound travels faster, and so sound in a lower layer overtakes that in higher layers, so the 'sound ray' is curved upwards: at ground level, at a given distance the sound level will be less than what it would be in air of uniform temperature (Fig. 3.19). At night, when temperature inversion occurs (the ground surface is cooled by outgoing radiation), it is in the upper (warmer) layers where the sound travels faster, thus 'sound rays' are deflected downwards, reinforcing the sound near ground level (Fig. 3.20).

**3.3.1.2 In buildings** sound can be transmitted from one room to another not only through a dividing partition, but through a number of flanking paths, as indicated by Fig. 3.21. Sound insulating properties of a partition or dividing wall can be expressed in two ways:

- (1) as a sound reduction index (SRI) or transmission loss (TL) – the two terms mean the same – in units of dB;
- (2) as transmittance ( $\tau$ ), which is a coefficient of intensity (I) or rate of energy transmission.

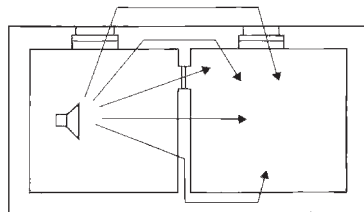
Similarly to light transmission, sound energy incident on a solid object (such as a partition) would be distributed three ways: part of it can be reflected ( $\rho$ ), part of it absorbed ( $\alpha$ ) and the remainder transmitted ( $\tau$ ). The sum of these three components is unity:  $\rho + \alpha + \tau = 1$ .

If the sound intensity on the source side is  $I_s$ , the transmitted (received) sound intensity will be  $I_r = I_s \times \tau$  but if the sound level on the source side is  $L_s$ , then the sound level on the receiving side will be  $L_r = L_s - TL$ .

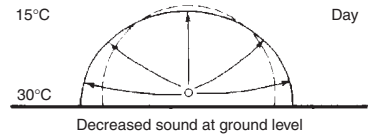
Thus,  $TL \propto (1/\tau)$  (or the loss is proportionate to that NOT transmitted).

The relationship is

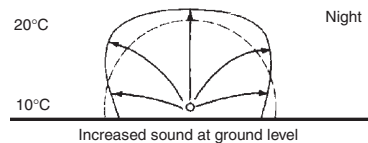
$$TL = 10 \log(1/\tau) = 10(-\log \tau) \tag{3.7}$$



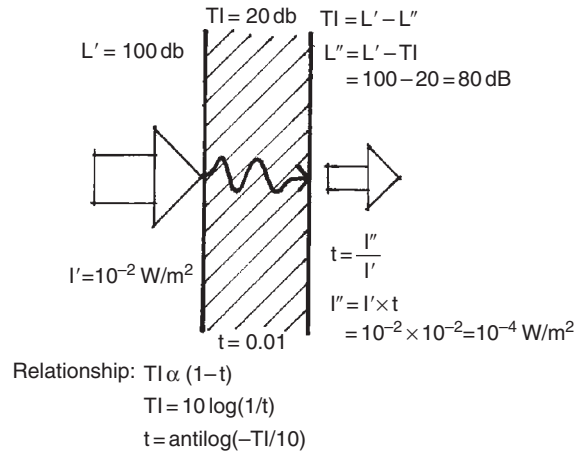
**Fig. 3.21**  
Sound transmission paths between two rooms.



**Fig. 3.19**  
The effect of daytime temperature gradient.



**Fig. 3.20**  
The effect of temperature inversion at night on a sound wavefront.



**Fig. 3.22**  
 An example of expressing transmission two ways ( $\tau$  is denoted  $t$ ).

Conversely

$$\tau = \frac{1}{\text{antilog}(TL/10)} = \text{antilog} \frac{-TL}{10} \tag{3.8}$$

The definitions of Fig. 3.22 can be written as

$$TL = L_s - L_r \quad \tau = I_r/I_s$$

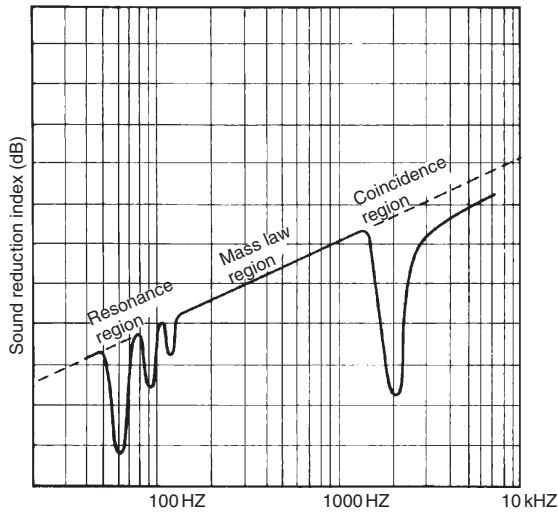
The *mass law* states that every doubling of surface density (or unit area mass) of a partition increases the TL by 6 dB and

$$TL \approx 20 \log M, \quad \text{where } M = \text{surface density, kg/m}^2.$$

In practice, due to various imperfections an increase of 5 dB in TL is more likely to be achieved by doubling the mass or  $TL \approx 17 \log M$ .

Transmission is also frequency dependent. If a molecule of a body has to vibrate faster (at higher frequency), its dampening effect will be greater. Thus, the mass law also states that TL will increase by 6 dB for every doubling of the frequency. Therefore, the TL graph as a function of frequency will show an upward slope. This TL will however be reduced by (a) resonance and by (b) coincidence. The first depends on the resonant frequency of the wall. For sounds at this frequency (or its upper harmonics), the TL is very much reduced. The second, coincidence, depends also on the angle of incidence of sound, as the incident wavefronts sweep the wall surface. As Fig. 3.23 indicates, (a) is likely to cause problems in buildings at low frequencies, and (b) the high frequencies. The mass law will be fully operative in the medium





**Fig. 3.23**  
A transmission graph showing resonance and coincidence regions.

frequencies only. The purpose of sound insulation improvements is to push the resonance region downwards and the coincidence region upwards.

Data sheet D.3.3 gives the TL values of various building elements for different frequencies and an overall average. Some simple empirical expressions for the average TL of solid, homogeneous elements are:

$$TL = 18 \log M + 8 \quad \text{if } M > 100 \text{ kg/m}^2 \quad (3.9)$$

and

$$TL = 14.5M + 13, \quad \text{if } M < 100 \text{ kg/m}^2 \quad (3.10)$$

or for the TL in any octave-band

$$TL_f = 18 \log M + 12 \log f - 25,$$

where  $f$  = octave-band centre frequency.

The highest achievable TL value is 55–60 dB. When the TL of a partition reaches about 50 dB, the flanking transmission paths become progressively more and more dominant.

Method sheet M.3.1 shows the calculation of average TL values for a dividing element consisting of different components, e.g. a partition with a door or a wall with a window. It shows that the 'chain is as good as its weakest link', that e.g. a relatively small opening can destroy the TL of a heavy wall.

For double-leaf walls or partitions (provided that the two leaves are not connected) the TL value will be some 8 dB higher than if the same mass were used in one leaf, e.g.

110 mm brickwork TL = 45 dB

220 mm brickwork TL = 50 dB

270 mm cavity wall TL = 58 dB

This improvement is however reduced at the resonant frequency, and at this frequency the TL of the cavity wall could become less than the solid double thickness wall.

For best effects the cavity should be at least 100 mm as the resonant frequency of this cavity would be lower. With light materials the resonant frequency can be well within the audible range, so the cavity should be wider. The coupling of the two skins by a resonant sound field in the cavity can be prevented by the introduction of some porous absorbent (e.g. a glass wool blanket). This may improve the TL by some 5 dB.

A special case of double walls is a double-glazed window. Here the most important point is to avoid acoustic coupling of the two layers. The cavity should be at least 200 mm wide, otherwise the cavity resonance will be well within the audible range. Airtight closure of both leaves is important and the reveals should be lined with an absorbent material to reduce any cavity resonance. To further reduce the probability of acoustic coupling, the two sheets of glass should be of different thickness, thus different resonant and coincidence frequencies.

### 3.3.2 Control of environmental noise

The main sources of environmental noise would be

- (a) industry
- (b) road traffic
- (c) air traffic.

It is far easier (and far less expensive) to control noise at or near the source than at some distance from it. Often the noise generated is an avoidable by-product of some process. Careful design can eliminate or at least reduce this. Often a mechanical component generates a vibration (which may be below the audible range), which is transmitted e.g. to some sheet metal component, which

will vibrate, perhaps at some upper harmonics of the original frequency, and emit sound. It is the task of equipment designers to avoid vibration (e.g. by good balancing) and prevent the transmission of such vibration (e.g. by using flexible mountings or flexible connectors in a duct or pipework).

*Impact noise* can be reduced at the point where the impact would transmit mechanical energy into the building fabric, by e.g. a resilient lining. The most common form of this is the use of carpets with underfelt.

*Airborne noise* emission from a source can be reduced by some form of (possibly partial) enclosure. A complete and heavyweight enclosure would be the most effective. If it has some openings (e.g. vents), then the inside could be lined with absorbent materials to reduce the sound field. If access is needed (e.g. for an operator of some machinery, a four-sided box can be installed, with one side open, and lined with absorbents. Fig. 3.24 shows a possible partial enclosure and its sound reduction effect in directional terms.

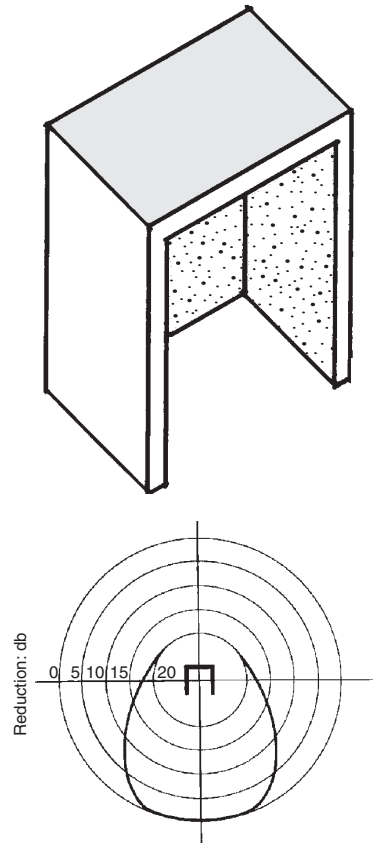
The above is of primary importance for industrial noise. For road traffic noise reduction, the road user vehicles should be as quiet as possible. As traffic noise is a function of average speed, speed controls can have an effect. Possible road-side barriers will be discussed in the next section.

High-flying aircraft have little effect on environmental noise at ground level. The problem is more acute around airports as aircraft come low to land and even more so at take-off. Only regulatory and planning measures can have desirable effects, such as banning aircraft movements between (say) 23:00 and 5:00 h, by requiring aircrafts to use less than maximum power (thus maximum noise) at take-off (e.g. sound level metering at the end of the runway, with penalties set if a noise limit is exceeded). Planning measures could include, in the first place, locating the airports in non-sensitive areas, e.g. on a peninsula, or where at least the main take-off path is over water or non-residential (e.g. industrial/agricultural) areas.

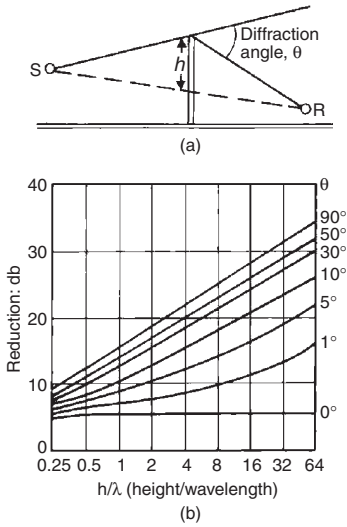
Planning measures can greatly reduce the noise problem, if zones of noise producing industries are kept separate from noise sensitive, e.g. residential areas. In positioning industries (and other noise sources), the directionality of the source must be taken into account, to point away from noise sensitive zones and to be down-wind from such zones. (N.B. This should also be done for reasons of air pollution.)

Building design measures would consist of having sealed buildings in the noise-affected area, with good noise insulation, which would imply the use of mechanical ventilation or air conditioning.

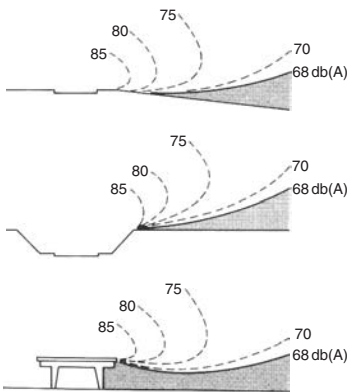
The control of community noise, as discussed in Section 3.2.4 is a regulatory question and very much dependent on reasonableness, a responsible attitude to noise generation and on consensus.



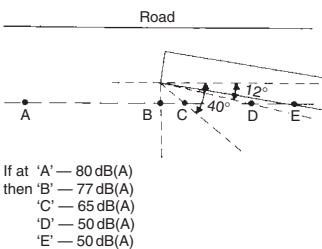
**Fig. 3.24**  
A partial enclosure for sound control and its effect on sound distribution (polar curve).



**Fig. 3.25**  
(a) A noise barrier: defining  $h$  and  $\theta$ . (b) Its sound reduction effect.



**Fig. 3.26**  
Noise contours at roads: on level, in cut and elevated.



**Fig. 3.27**  
A building as barrier and its effect.

### 3.3.3 Barriers and sound insulation

*Barriers*, such as walls, screens or other objects (including buildings) create an acoustic shadow. The attenuation within this shadow depends on the frequency of the sound. Whilst high frequency sounds behave similar to light, at low frequencies much diffraction can occur at the edge of the barrier, which will diminish the shadow effect. One method of predicting this shadow effect requires the calculation of the  $h/\lambda$  (height/wavelength) quotient and determination of the 'diffraction angle' ( $\theta$ ) belonging to the receiver's point (see Fig. 3.25a).

Note that 'height' is taken only as above the straight line connecting the source with the receiver. The reduction (in dB) can then be read from the graph (Fig. 3.25b). This shows that the effect is much greater with a larger  $\theta$  angle (nearer to or higher barrier) and at larger  $h/\lambda$  ratios (shorter wavelengths). Other methods to estimate the barrier effect are given in method sheet M.3.2.

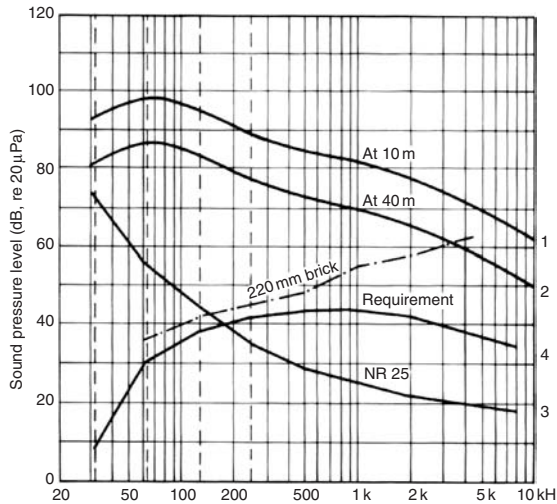
For any noise barrier to be effective, it should have a surface density of not less than  $20 \text{ kg/m}^2$ . A 10-mm thick dense concrete panel, 15-mm fibrous cement sheeting, or a 30-mm hardwood boarding would satisfy this requirement.

Noise effects from a road can be lessened by placing it either in a cutting or by having an elevated road. Fig. 3.26 shows the expected noise contours adjacent such roads.

If a large site is available, the first step would be to place the building as far away from the noise source as possible. If possible, any building should be placed outside the 68 dBA contour. The area between the building(s) and the noise source could be heavily vegetated. The noise reduction effect of such 'tree-belts' is given in D.3.2. Shaping the terrain, e.g. forming a mound or a hill can provide a barrier effect.

In some residential developments near busy roads (e.g. motorways) certain blocks of flats have been designed to act as barrier blocks. These would have all habitable rooms facing away from the noise source road, have service areas on the side facing the road, with very small windows. The best arrangement is if this block is parallel with the road. The difference in noise exposure between the two sides of such a block can be as much as 30 dBA. If the sheltered side is at an angle to the road, the reduction is less, as indicated by Fig. 3.27.

If all these measures are insufficient, then the building envelope itself must be noise insulating. If the building is at the 68 dBA contour, the TL of the envelope should be at least 20 dB, but preferably 25 or 30 dB. D.3.3 shows that most wall elements are more than adequate. However, the weakest points are airbricks, ventilator openings and windows. If the overall noise insulation is not enough, the most economical measures would be to improve these weak points. A single-glazed window, with



**Fig. 3.28**  
Spectral analysis for required insulation.

TL = 22 dB, would be just about enough, but openings should be avoided.

For buildings acoustically more critical, a full spectral analysis should be carried out. This is best illustrated by an example.

### Example 3.2

The analysis can be carried out graphically (Fig. 3.28) or in tabulated form (Table 3.4). A lecture theatre block is to be built near a busy road. The noise measured at 10 m from the road centreline has a spectrum shown by line 1. The site is large enough to allow placing the building at a distance of 40 m from the road. This means two 'doublings' of the distance, i.e. a reduction of 12 dB. The reduced spectrum is line 2. The requirement is that the intruding noise should be no more than NR25 (from D.3.1). This is drawn as line 3. The difference between lines 2 and 3 is the noise insulation requirement, and this is now plotted up from the base line (line 4). The next step is to select (e.g. from D.3.3) a form of construction which would give the required TL values in each octave. It will be seen that for 1000 Hz and above, a 110 mm brick wall would be adequate, but the traffic noise is strong in low frequencies. The critical octave will be 125 Hz, thus 220 mm brick must be used. The octave-band TL values of this are plotted and are given in Table 3.4.

**Table 3.4** Spectral analysis in tabulated form

Octave band centres (Hz)	63	125	250	500	1000	2000	4000	8000
1 At 10 m from road	98	95	89	85	81	77	71	64
2 At 40 m from road	86	83	77	73	69	65	59	52
3 NR25	55	44	35	29	25	22	20	18
4 Insulation required	31	39	42	44	44	43	39	34
5 TL of 220 mm brick		41	45	48	56	58	62	
6 TL of 110 mm brick		34	36	41	51	60	67	

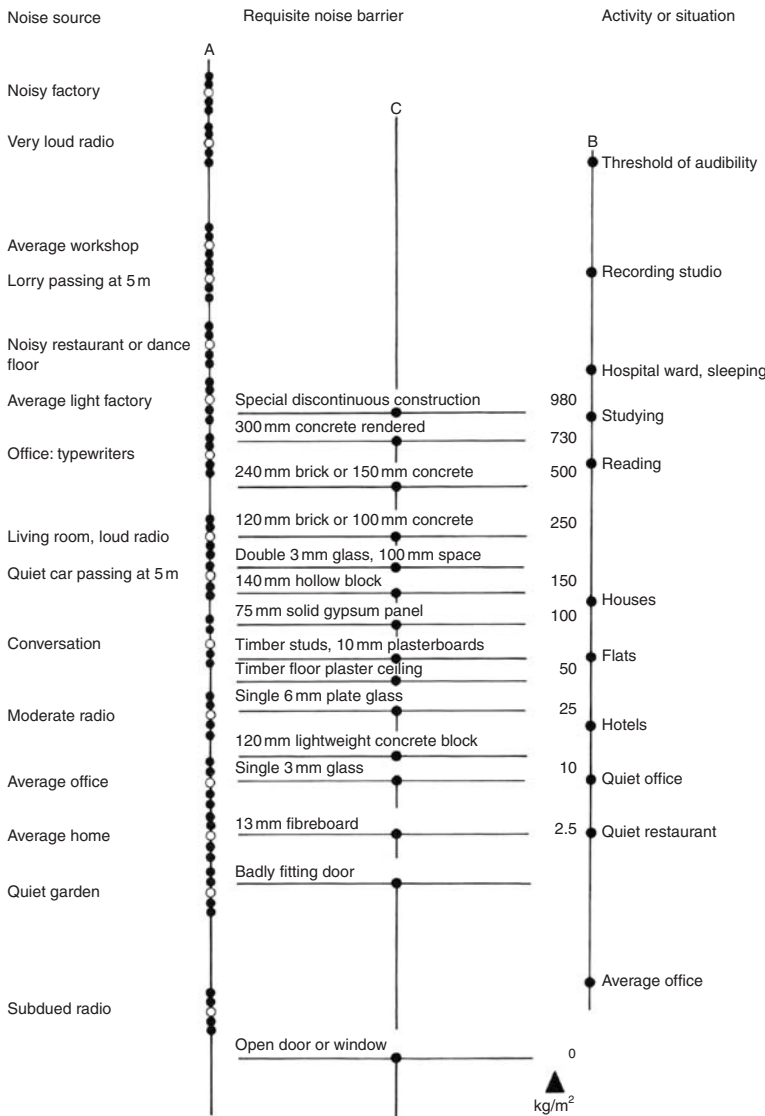
If one examines D.3.3 it is apparent that no window would satisfy the insulating requirements, therefore there cannot be any windows in this (most exposed) wall.

In many countries, building regulations prescribe airborne sound insulation requirements between different occupancies, such as party walls in terrace (row-) houses and flats, as well as floors between flats or maisonettes. Some regulations specify only the sound transmission class (STC) values for such separating elements, but these are no substitute for an octave band analysis.

The Australian experimental building station (EBS) produced a 'noise control nomogram', which is shown as Fig. 3.29. The first column shows the noise source in one space and the last column shows the receiver space functions. A straightedge laid across will show in the middle column what construction would be adequate to separate the two.

**3.3.3.1 Structure-borne sound insulation** is a totally different problem. Whilst airborne sound impinging on a building surface would generate some vibration in the fabric, i.e. some structure-borne sound, it would be of negligible level. Structure-borne sound is significant where it would be generated by mechanical impacts or vibration. (Impact noise is often confused with structure-borne noise, as they are strongly connected. Impact is the source, the structure transmits the noise.) Impacts are the major source of structure-borne sound, but not the only source. It can be reduced at the source (as mentioned in Section 3.3.2) by resilient linings, and its transmission can be prevented (or reduced) by structural discontinuity.

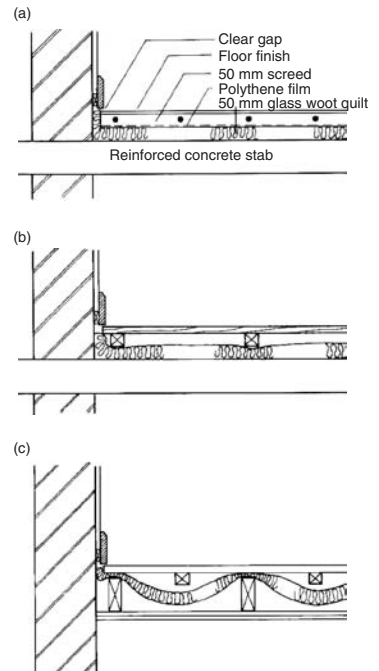
The most likely source of structure-borne sound is footsteps or dropping objects on a floor. Dropping a spoon on a kitchen floor (a tiled concrete slab) can generate a noise of over 80 dB in the room below. It would be a short transient noise, quickly dying away, but can be quite disturbing. Fig. 3.30 shows some arrangements for 'floating floors', where a resilient layer would isolate



**Fig. 3.29**  
A noise control nomogram.

the floor surface from the structural floor below it. Some building regulations prescribe the use of such floors between separate occupancies (e.g. flats).

Note however, that structure-borne and airborne sound insulation are two separate matters. Fig. 3.30c may provide discontinuity, but may not give an adequate TL for airborne noise insulation. The table of TL values given in D.3.3 relate to airborne noise

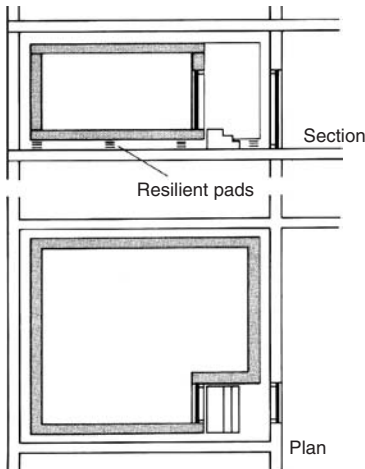


**Fig. 3.30**  
Some 'floating floor' arrangements to reduce impact noise transmission.

transmission. D.3.4 tabulates both the TL and the impact grading values of various floor constructions.

Structural discontinuity may also have a role in double layer partitions. One leaf may be rigidly connected to the floor below and above as well as the adjoining main walls, but the second leaf should sit on flexible mountings and be isolated all around from the adjoining elements, at least by a cork strip. This would reduce the structureborne transmission of vibrations.

As an example, take a 220 mm solid brick wall, both sides plastered, with a surface density of  $440 \text{ kg/m}^2$ . Compare the possible improvements, without changing the wall mass:



**Fig. 3.31**  
A fully isolated construction:  
a 'floating room'.

The original 220 mm solid brick wall	$\text{av TL} = 50 \text{ dB}$
Two skins of 110 mm of the same	53
With a glass wool quilt in the cavity	58
Same, but one skin isolated	60

The theoretically possible limit is a TL of about 62 dB.

The ultimate in isolated construction or structural discontinuity is a 'floating room', the kind of construction used for some acoustic laboratories or other extremely noise-sensitive rooms. An example of this is shown in Fig. 3.31. It is a room within a room, where the inner shell is not in rigid contact with the outer building structure, and sits on flexible mountings.

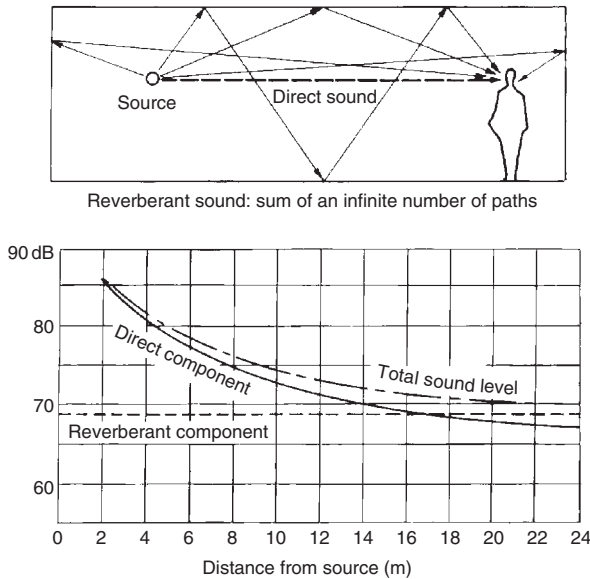
Such construction has been used for the old BBC studios in Portland Place (London), to isolate them from the underground railway running immediately underneath, for the Royal Festival Hall (London) or for some laboratories at the BRE in Garston.

### 3.3.4 Noise control by absorption

The task of the designer may be to reduce the noise level in the room where the noise source is. As Fig. 3.32 shows, the sound field at any point in a room consists of two components: direct and reverberant sounds. The direct component reduces with the distance from the source, but the reverberant component (all possible reflections and interreflections) is taken as homogeneous throughout the room, and is dependent on room surfaces.

As mentioned in Section 3.3.1.2, sound incident on a surface can be reflected, absorbed and transmitted, thus reflectance + absorptance + transmittance:  $\rho + \alpha + \tau = 1$ . From the point of view of a room where the sound is generated and considered, the *absorption coefficient* ( $\alpha$ ) is **all that is not reflected**. Thus,  $\alpha = 1 - \rho$ , or  $\alpha = 1 - \rho - \tau$ . Indeed the unit of absorption is the 'open window unit' which does not reflect any sound ( $\alpha = 1$ ), and it is measured





**Fig. 3.32**  
Direct and reverberant sound in a room.

in  $m^2$ . The total absorption ( $A_{bs}$ ) in a room is the sum of all surface elements area ( $s$ )  $\times$  absorption coefficient ( $a$ ) products.

$A_{bs} = \sum(s \times a)$ . Data sheets D.3.4 and 5 list the absorption coefficients of numerous surfacing elements and proprietary products.

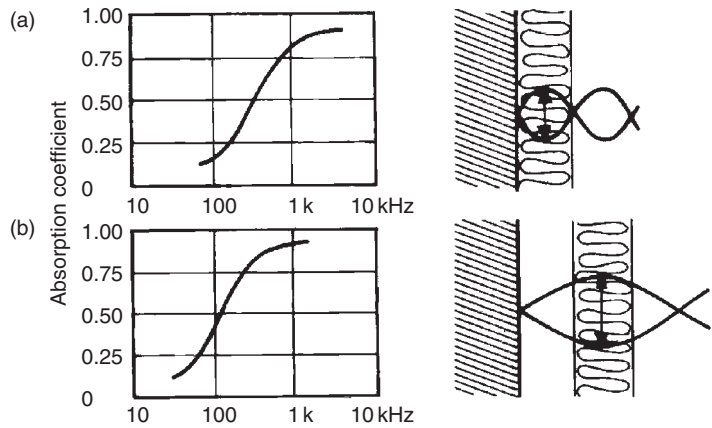
It is this total absorption that determines the reverberant component. If the absorption is doubled, the reflected power is reduced by half, which means a reduction of 3 dB in sound level (as  $10 \log \frac{1}{2} = -3$ ).

In a room, which has poor absorption (all hard surfaces), it may not be too difficult to increase the absorption by a factor of 8 (three doublings or  $2^3$ ), which would give a reduction of 9 dB. However, if the room already has highly absorbent surfaces, it may be quite difficult (and expensive) to produce even one doubling.

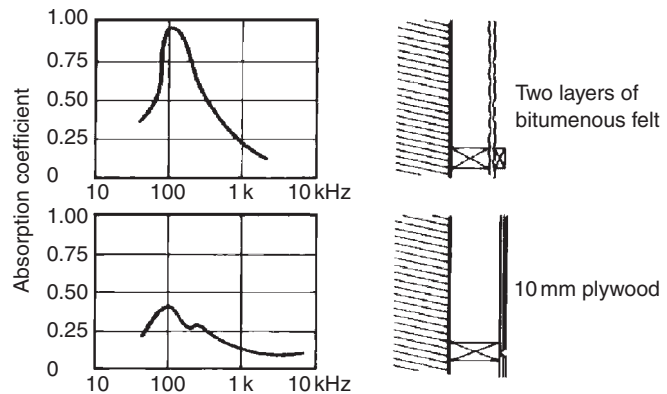
For most room surfaces, if transmittance is negligible, the absorption coefficient is the same as absorptance:  $a = \alpha$ .

There are four basic types of absorbers, the absorption being due to different processes:

- 1 *Porous absorbers*, such as mineral wool, glass wool, fibreboard or plastic foams which have an open cell structure (Fig. 3.33a). Vibrations are converted to heat by the friction of vibrating air molecules and the cell walls. These are most effective for high frequency (short wave) sounds. If the thickness ( $b$ ) is less than quarter wavelength ( $b < \lambda/4$ ), they have little effect. If such a sheet is fixed at some distance from a solid surface (Fig. 3.33b),

**Fig. 3.33**

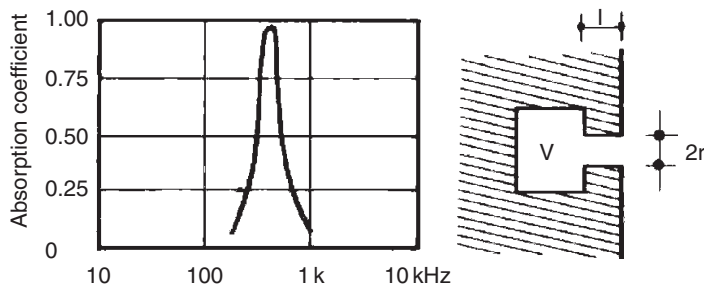
Porous absorbers: (a) fixed to a solid wall, (b) spaced out e.g. by battens.

**Fig. 3.34**

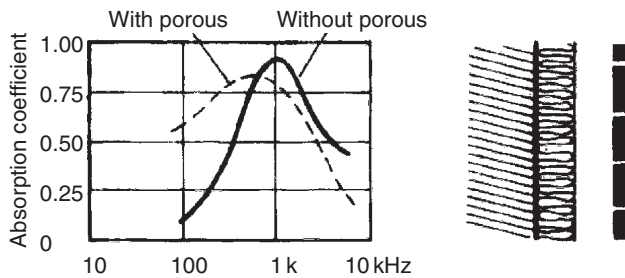
Membrane type absorbers.

it will have almost the same effect as a thicker absorber. It will be most effective for sounds with a  $\frac{1}{4}$  wavelength equal to the distance from the solid surface to the centre of the absorber. In this case the maximum amplitude of both the incident and the reflected wave would occur within the porous material.

2 *Membrane absorbers* may be flexible sheets stretched over supports, or rigid panels mounted at some distance from a solid wall. Conversion to heat would occur due to the rapid flexing of the membrane and repeated compression of the air behind it. These will be most effective at their resonant frequency, which depends on the surface density of the membrane, the width of the enclosed space and on the fixing and stiffness of the membrane or panel. Most such absorbers are effective in the low frequency range (Fig. 3.34).



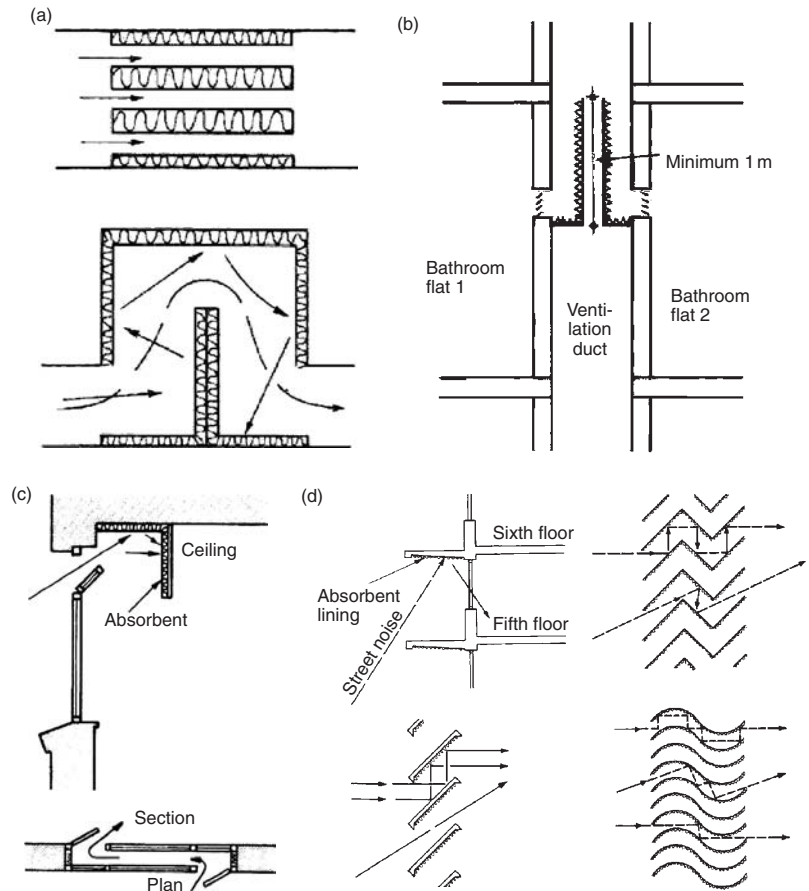
**Fig. 3.35**  
A cavity resonator absorber.



**Fig. 3.36**  
A perforated panel absorber.

- 3 *Cavity (Helmholz) resonators* are air containers with a narrow neck (Fig. 3.35). The air in the cavity has a spring-like effect at the particular resonant frequency of the enclosed air volume. These have a very high absorption coefficient in a very narrow frequency band. Large pottery jars built into stone walls with their opening flush with the wall surface are the original examples from Greek amphitheatres.
- 4 *Perforated panel absorbers* combine all three of the above mechanisms (Fig. 3.36). The panel itself may be plywood, hardboard, plasterboard or metal and many act primarily as membrane absorbers. The perforations, holes or slots with the air space behind them act as multiple cavity resonators, improved by some porous absorber. Most of the broad spectrum commercially available acoustic materials (e.g. ceiling tiles) fall into this category.

Absorption has a role in reducing the noise level in a given space where the noise source is (as discussed above), but its role is most important in designing for room acoustics, which will be discussed in Section 3.4.



**Fig. 3.37**

(a) Absorbent baffles in ducts. (b) Absorbent baffle between two bathrooms. (c) An absorbent pelmet and a ventilator. (d) Absorbent lining of soffit and absorbent louvres.

There are several misconceptions prevalent in this context. Many people confuse absorption with insulation, probably because some materials are used for both purposes. *Fibrous materials* (glass – or mineral wool) are good for thermal insulation but useless for noise insulation. Air vibrations would penetrate these like a sieve. If it is possible to blow air through them, sound will travel through them with very little loss. They may be good absorbers when mounted on a solid backing, reducing reflections. For noise insulation, that is for stopping noise going through a wall or partition, mass is the best answer.

The case is different with *porous materials*. For thermal insulation, the best ones have a closed pore structure, such as polystyrene, but

these would be useless for acoustic absorption, where an open pore structure is best.

Similar materials, e.g. a glass fibre quilt can be used to reduce impact noise transmission, e.g. for supporting a floating floor. Here it is not any absorbent property which would be used, it is only providing a resilient support for a 'floating floor', to break the rigid connection and thus the path of structure-borne sound transmission.

Another instance which may cause confusion is the use of absorbent materials in the cavity of a double layer construction. Here the mechanism of transmission is that as the source-side skin vibrates, it sets up a sound field within the cavity, which will in turn cause vibrations in the second skin. This is referred to as 'acoustic coupling' of the two skins. Placing some absorbent in the cavity would reduce the intensity of the sound field, and thus reduce the effect on the second skin. The overall effect is an improved TL.

Absorbers can be applied to reduce sound going through openings, which must be kept open for ventilation purposes. The most common example of this is the 'silencer' of car exhaust pipes. In air conditioning, a 'silencer' is fitted in after the fan, to absorb aerodynamic noise created by the fan (Fig. 3.37a). If a ventilation duct serves two bathrooms, an absorbent section is provided to stop sounds going across, to ensure aural privacy (Fig. 3.37b).

A ventilator opening in a window would admit noise: this can be reduced by an absorbent lined pelmet or baffles or by a double window with absorbent reveals (Fig. 3.37c). This will not be 'noise insulation', only a reduction of noise penetration by absorption.

In hot climates, where the window is kept open for natural ventilation, the absorbent lining on the soffit of a canopy or on the ceiling near the window would produce some reduction in the transmitted noise. Even louvres used in windows to allow ventilation can have such absorbent lining (Fig. 3.37d). Rarely would even the best of such absorbent openings produce a reduction in sound level more than about 6 dB.

### 3.4 Room acoustics

In a room when a sound source is switched on and it operates at a steady level, the intensity of the sound field increases (the room – as it were – is being filled with sound) until the energy absorption rate equals the energy input rate. At that point equilibrium would exist and the sound field would be steady.

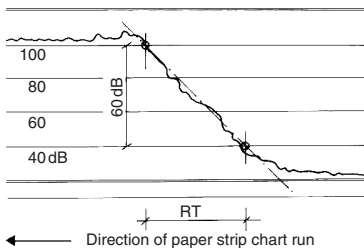
When the source is switched off, the reverberant sound field would persist for a little time as it gradually decays. The time taken for the sound field to drop by a factor of a million ( $10^6$ ), i.e. a drop in sound level of 60 dB, is referred to as the *reverberation time* (RT). The length of this time depends on the size of the room and the room surfaces. A little energy is lost at each reflection. With hard surfaces it will take more reflections, thus a longer time for the sound to decay. In a larger room the sound travels a longer time between reflections, there are fewer reflections in unit time, thus RT is longer.

A simple empirical expression has been proposed by Sabine for the calculation of RT:

$$RT = 0.16 \times \frac{V}{Abs} \text{ (in s)} \quad (3.11)$$

where  $V$  = volume of room ( $m^3$ ),  $Abs$  = total absorption in room ( $m^2$ ).

Fig. 3.38 shows a paper strip on which the sound level is recorded graphically against time, referred to as the 'decay curve' and it defines the RT.



**Fig. 3.38**  
Chart recording of RT.

### 3.4.1 Requirements

A room, where listening to some sound is an important function is said to have 'good acoustics' if the following conditions are satisfied:

- (1) any background noise is low enough and the wanted sound is loud enough for it to be audible, intelligible, enjoyable and free of disturbance;
- (2) the sound field is well diffused, free of deaf spots and loud zones;
- (3) there are no echoes, flutter echoes, standing waves or other acoustic distortions;
- (4) RT is appropriate for the purpose and well balanced across the audible frequencies.

In spaces where voice communication (listening to speech) is important, the noise limits can be set in terms of *speech interference level* (SIL). As for human speech, the most important frequencies are 500, 1000 and 2000 Hz. This has been defined as

$$SIL = \frac{L_{500} + L_{1000} + L_{2000}}{3} \quad (3.12)$$

i.e. the arithmetic average of the three octave-band sound levels.

Comparing this with Fig. 3.12, it can be seen that the NR curves are in fact a straight line from 500 to 2000 Hz, which coincide

with the SIL. The SIL is a subset of the NR curves. Frequencies below 500 and above 2000 Hz are less important for speech intelligibility.

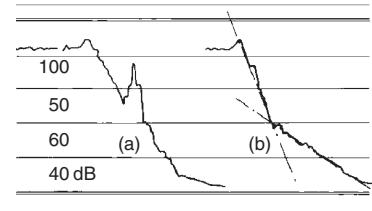
### 3.4.2 Room size and shape

Up to about 300 m<sup>3</sup> room volume, a single voice can be heard without difficulty and without any special treatment of room surfaces. Echoes are unlikely to occur, but if one room dimension is less than the half wavelength of the lowest audible frequency (some 8.5 m), standing waves can develop between parallel opposing (reflective) surfaces. This causes room resonance, i.e. an increase in loudness and RT for the particular frequency.

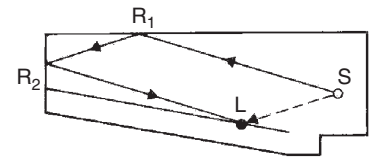
As the room size increases from 300 to 30 000 m<sup>3</sup>, the need for reinforcement of the sound for the further part of the audience also increases. Geometrical acoustics help determine room surfaces for directed reflections. If a single voice is to be intelligible, an amplification system may be necessary in rooms larger than about 8000 m<sup>3</sup>. In larger auditoria, standing waves are unlikely, but echoes can occur. Good diffusion and correct RT will be critical.

In normal speech, 6–10 syllables are pronounced per second, which, on average, corresponds to 0.13 s per syllable. The same sound may arrive at a listener first by a direct path and after a reflection again, with a time delay. If this delay is within 0.035 s (35 ms), the second arrival will not be distinguishable from the first; it will reinforce it. If the delay is more than about half the time per syllable (0.06–0.07 s), it will be perceived as a repetition of the same sound, i.e. an *echo*. A delay between the two limits (0.035 and 0.07 s) may give a blurring effect. Fig. 3.39 shows the decay curve with a distinct echo and one with a *flutter-echo*. The latter may be experienced in interconnected rooms or a room with a (large) alcove, but also (at particular frequencies) between opposing parallel surfaces.

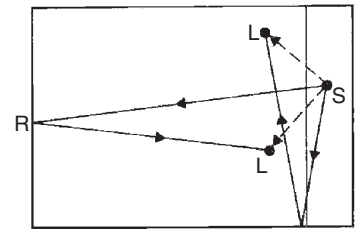
In 0.06 s sound would travel some 20 m. If there is a difference in path length larger than this between the direct and reflected sound, an echo will be perceived. Fig. 3.40 shows some situations where echo could occur. This could be avoided by checking room geometry both in plan and in section, to find any situation where a path-length difference over 20 m could occur and using highly absorbent materials for surfaces which could produce such unwanted reflections. A special case is the *corner echo*, in rectangular corners, where the sound may be reflected, returned parallel with the original. These can be avoided if there are no rectangular corners, if the wall and a 1–2 m strip of the ceiling are lined with absorbents. The most likely culprit in an auditorium is the rear wall, which should be as absorbent as possible. To avoid



**Fig. 3.39**  
An (a) echo and a (b) flutter echo: double slope, due to interconnected rooms, or an alcove.

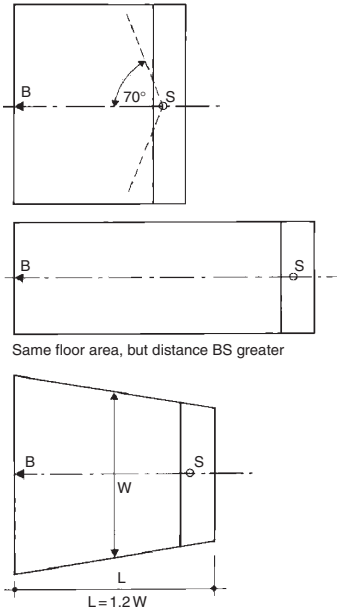


Corner echo:  $SR_1R_2L > SL + 20\text{ m}$

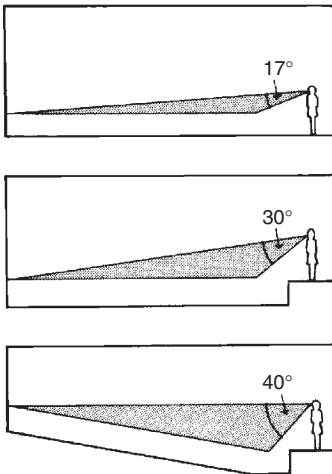


For both:  $SRL > SL + 20\text{ m}$

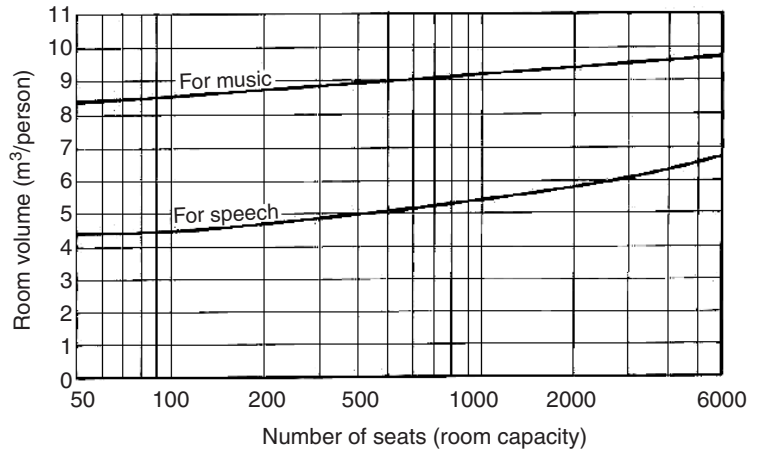
**Fig. 3.40**  
Situations where echo could occur: an auditorium, section and plan.



**Fig. 3.42**  
Basic issues for plan shape of auditoria.



**Fig. 3.43**  
Sound received by audience: sectional considerations.



**Fig. 3.41**  
Recommended minimum volume of auditoria.

any flutter echo or standing waves, the side walls should not be parallel, should be divergent by at least 2.5–3° relative to the longitudinal axis.

For reasons of economy and for the best non-amplified sound, the auditorium should be as small as possible, but a lower limit is set by the need for some reverberation. Fig. 3.41 indicates the minimum volume of auditoria (as a function of number of seats) for speech and for music. The room can be made larger than indicated, at the expense of using more absorbent materials.

The best sound is received in the ‘near field’ where the direct sound dominates over any reflections. This suggests that the distance between the speaker (or sound source) should be as small as possible: a short, wide room is better than the same area in an elongated form. Intelligibility is reduced beyond about 70° from the direction the speaker is facing, and this sets a limit to width. The length should be between 1.2 and 2 times the width of the room. A trapezoidal plan may have several advantages (Fig. 3.42).

Geometrical acoustics (using light beam and reflection analogies) can help to solve many acoustic problems. The designer’s aim is to get most of the sound emitted by the source to the audience directly and evenly. Fig. 3.43 indicates that in a lecture room with a flat floor, the audience would receive sound from within a (vertical) angle of 17° from the source. Putting the speaker on a dais can increase this to some 30° and a raked floor to 40° and more. The floor slope should be at least 8°, but in lecture theatres (especially if demonstrations are to be visible) 15° is justifiable. Method sheet M.3.4 gives the setting out technique for what is referred to as the ‘progressive rake’.



If preference is for direct sound, the second best is the 'first reflections', i.e. for receiving sound reflected only once (before it dissipates into the general reverberant field), which would reinforce any direct sound received. Fig. 3.44 indicates how part of the ceiling can be used to direct such reflections to the rear part of the audience, or how a *sounding board* can be positioned above the source for the same purpose.<sup>1</sup> Progressive reinforcement is also possible: one sounding board serving the rear two-thirds, and a second sounding board directed at the rear one-third of the audience.

Serious distortions can be caused by the focusing effect of concave room surfaces. A dome or a circular room can create a very uneven sound field, but a room with a curved rear wall is also liable to cause such a focusing effect. Fig. 3.45 indicates these, but also shows that (in the latter case) the rear wall can be broken up into convex segments to diffuse the sound. In many auditoria (such as the Albert Hall in London), the solution was to suspend discs of various sizes (double convex 'flying saucers') from the ceiling at many points, to disperse and diffuse the sound.

From any part of the auditorium the sound source must be visible, but acoustic shadows must be avoided which would deprive parts of the audience of reflected sound reinforcement. Fig. 3.46 shows such a case, the shading effect of a balcony and how it could be overcome.

### 3.4.3 Room surfaces

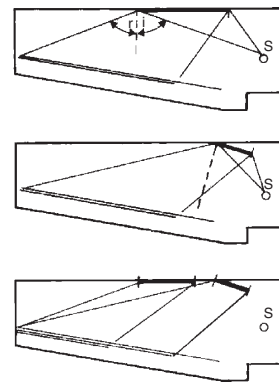
For listening to speech, the most important criterion is *clarity*. Long RT gives a booming effect, it would reduce clarity. Hence for speech a short RT is desirable. For music, *fullness of tone* is a main criterion. This requires a longer RT. Fig. 3.47 gives the desirable RT for speech and large orchestral music. For chamber music or multipurpose halls, the RT should be between the two limits. For music, the given times are valid for 500 Hz and above. The given times should be multiplied by 1.15 for 250 Hz and by 1.5 for 125 Hz.

As shown by Eq. 3.11, RT depends on room volume and on the total absorption. If the volume is given, the required total absorption can be found by inverting the same equation:

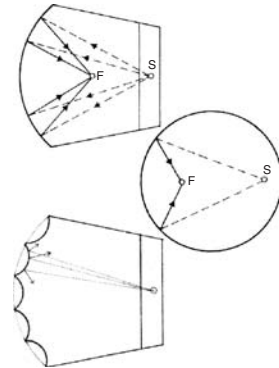
$$Abs = \frac{0.16V}{RT}$$

A large part of the Abs will be the sum of the products of each component surface area (s) multiplied by its absorption

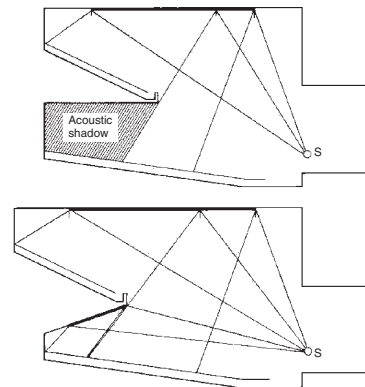
<sup>1</sup> Sound reflections follow the rules of reflection of light: angle of reflection is the same as the angle of incidence. A study of such reflections is often referred to as 'optical acoustics'.



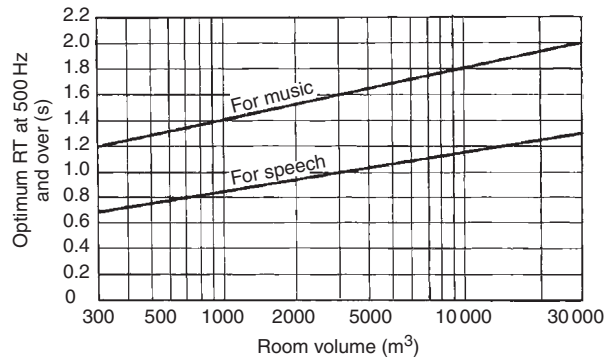
**Fig. 3.44** Sound reinforcement by reflections.



**Fig. 3.45** Concave shapes: risk of focusing and uneven sound field and a possible improvement.

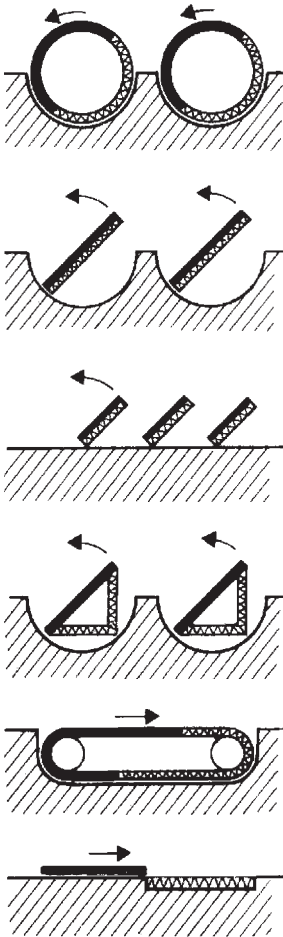


**Fig. 3.46** Acoustic shadow caused by a balcony and a way to avoid it.



**Fig. 3.47**

Recommended RTs for speech and music.



**Fig. 3.48**

Systems to provide variable absorption.

coefficient (a). Another significant part may be what is referred to as 'room contents', which includes at least people and seats, but (at high frequencies) also room air. D.3.4 and D.3.5 give the absorption coefficients of many materials as well as the total absorption values of some room contents. Method sheet M.3.3 shows a worked example of RT calculation for the design of room finishes. Note that values averaged for all frequencies are to be avoided, and the calculations should be carried out for at least three frequencies (at two octave distances). A number of simple computer programs are available to carry out such calculations, which may involve numerous trial-and-error loops and may be quite lengthy if done manually.

It is not too difficult to achieve the desirable RT for a particular room use and assumed occupation. If the room is to be used for different purposes or if it is to work well for different occupancy rates, some variable absorbers may have to be used. It is customary to design an auditorium for between  $\frac{2}{3}$  and  $\frac{3}{4}$  of the seats occupied. To compensate for the absence of human bodies, the underside of tilting seats is made absorbent, but this cannot match the absorption of a human body. With a lesser occupancy, the RT will be longer and with a full house it will be shorter than the ideal. To compensate for this, a range of different surfaces of variable absorption can be provided. In the simplest case this can be just drawing a (heavy) curtain over a reflecting wall surface, but rotating or reversible panels can also be used, such as those shown in Fig. 3.48. Some electrical systems to serve the same purpose will be discussed in Section 3.4.4.

**3.4.3.1 Acoustic quality** can be quite elusive. It can happen that all four requirements listed in Section 3.4.1 appear to have been satisfied and the acoustic qualities of the room are still unsatisfactory. It is relatively easy to provide good listening conditions

for speech, but to ensure full enjoyment of music is more difficult. Many 'acoustic experts' have burnt their fingers. Some, even today, suggest that good acoustics is an 'act of god'. Beyond the four requirements discussed above, it is difficult even to define what constitutes good acoustics. An attempt should be made at least to define some of the terms used.

*Definition* means that the full timbre of each instrument is heard clearly, so that each would be individually distinguishable and also that successive notes can be distinguished even in a fast passage (up to 15 notes per second). The term *clarity* is often used with the same meaning.

*Blend* is not the opposite of definition, although it implies that a whole orchestra is perceived as a homogeneous source and the sound is not fragmentary.

*Balance* is the correct loudness ratio, as perceived at any point in the auditorium, both between different frequencies and between different parts of the orchestra. It implies that the room will not selectively influence the sound.

*Fullness of tone* is the term used synonymously with warmth, full body, sonority or resonance. It is absent if an instrument is played under open air conditions. It is the perception of the whole range of harmonics, but also the persistence of these harmonics for a few milliseconds. What the room does to the orchestra is similar to what the body of the violin does to the vibrations of the string.

In auditorium design very often too much emphasis is placed on the calculation of RT. This can be calculated quite accurately and in a clear-cut way. It is important, but it is not the only criterion. The location of absorbent and reflective surfaces is at least as important. If one side is more reflective than the other, the sound diffusion will suffer and even our binaural location sense may be deceived or may come into conflict with the visual. This may be most disconcerting for audience at the rear of the hall, where the reflected sound may dominate over the direct one. For example, large glazed areas on one side can cause a distortion of the spectrum. Glass is highly reflective for high frequency sounds, but it may absorb up to 30% of low frequency components, acting as a panel absorber. People at the back may lose the bass component.

Generally it is better to use absorbers in relatively small areas, alternating with reflective surfaces. In historical auditoria, good diffusion was achieved (often perhaps inadvertently) by the highly ornamented and sculptured surfaces. In some modern auditoria with large plain surfaces, an uneven and ill-balanced sound field has been produced.

There are now great expectations that electrical/electronic measures can be relied on to compensate for the lack of good room acoustics. I am yet to be convinced about this.

### 3.4.4 Electroacoustics

The trend in cinema design is to rely increasingly on the electrical sound system: in the room itself provide as much absorption as possible (to get the shortest possible RT), as all resonance, reverberation and other acoustic effects can be produced electronically and included in the sound track. This arrangement is probably where electroacoustics started. There are three items normally discussed under this heading:

- sound reinforcement systems
- acoustic correction systems
- acoustic measurements.

The first two will be discussed in this section in some detail, but the third one only briefly, as sufficient for architectural purposes.

**3.4.4.1 Sound reinforcement** is definitely necessary in auditoria seating more than 1500 people ( $\approx 8500 \text{ m}^3$ ), but it is desirable for rooms seating more than 300 people ( $\approx 1500 \text{ m}^3$ ). If the room has less than perfect acoustic qualities, or an intruding noise is louder than the recommended NR (e.g. in D.3.1), then these limits will be much lower.

A reinforcement system has three main requirements:

- 1 It is to provide an adequate sound level uniformly over the whole auditorium, so that there are no 'deaf spots' or loud areas.
- 2 It must not add any noticeable noise.
- 3 It should preserve the characteristics of the original sound, both in frequency composition and localisation.

Such a system consists of three main parts:

- a microphone
- an amplifier
- loudspeaker(s).

These may be connected by 'hard wiring' or may rely on high frequency radio transmitter/receivers.

*Ribbon or moving coil microphones* are based on electrodynamic effects, use a permanent magnet, which needs no polarising potential; their output is fairly large, thus they do not need a preamplifier. Disadvantages: they are rather bulky and their frequency response is limited. These microphones are rarely used these days.

*Condenser microphones* have a good flat response across all audible frequencies and over a wide range of sound levels and are widely used. Their electrical output is small, so they need a preamplifier, as well as a static polarising charge of some 100 V.

*Crystal microphones* rely on the piezoelectric effect and need a preamplifier. They are less vulnerable than the former ones and they can be placed in a liquid (to serve as a hydrophone).

**Table 3.5** Electrical speaker power requirements (W/100 persons)

Venue	For speech	Music	Dance music
High reverberation rooms	0.5	1	2
Low reverberation rooms	1.0	2	3
Open air	1.5	2	3

There are many different solutions for a microphone assembly, with different directionality characteristics. For sound measurement, omnidirectional (spherical) microphones are used, but these are undesirable in an auditorium, as they pick up the sound of loudspeakers and may generate a feedback effect: a howling, screaming noise. Directionally selective microphones are much preferred.

Amplifiers are not our subject, but it should be remembered that an oversized amplifier used at partial capacity gives a much better sound than a less powerful one stretched to its limits.

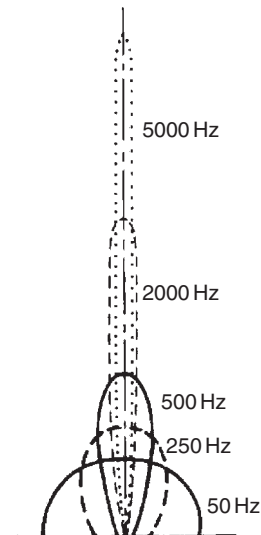
The average sound power in a medium-sized room without sound reinforcement, due to one human voice is some  $3 \times 10^{-6}$  W, but a loud voice can reach  $3 \times 10^{-3}$  (0.003) W. The electrical-to-acoustic power conversion efficiency of loudspeakers is 0.03–0.05. To match a loud voice, the speaker power would need to be  $P = 0.003/0.03 = 0.1$  W. A safety factor of 10–30 is usually applied to compensate for distribution deficiencies and to avoid using the speaker near its limits. Table 3.5 gives suggested electrical power for speakers, in terms of W per 100 person audience.

Ordinary box-mounted speakers tend to distribute low frequency sound almost spherically, but they have strong directional properties for higher frequencies (Fig. 3.49). A 'column speaker', i.e. 6–10 individual speakers mounted in a line produces strong directionality in the plane they share (normally vertical), whilst their sideways distribution is the same as of a single speaker (Fig. 3.50). Emissions of the top and bottom speakers 'constrain' the emission of the intermediate ones. This is an obvious advantage (and saving of energy) in open air situations or in large halls.

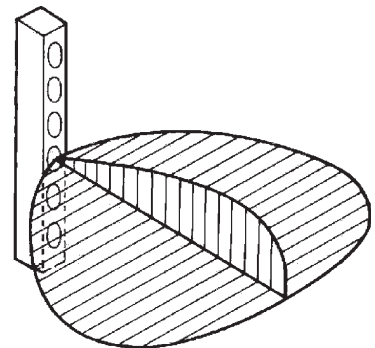
Two basic types of speaker systems can be distinguished:

- 1 High level (central) system, which consists of a few speakers (possibly columns), located near the dais or stage, near the original source, aimed at the audience to give an even coverage.
- 2 Low level (distributed) system, which uses many, small output speakers, distributed over the whole auditorium (usually ceiling mounted).

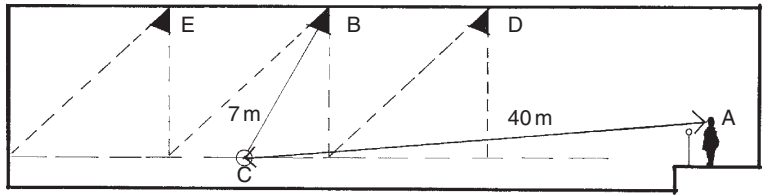
The former is less expensive, readily adjustable and has the advantage that the amplified sound comes from the same direction as



**Fig. 3.49** Directionality of speakers at various frequencies.



**Fig. 3.50** A column of speakers constrains the distribution vertically, but not horizontally.

**Fig. 3.51**

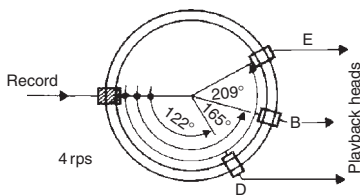
A low level speaker system for sound reinforcement.

the original. It can be disastrous in large, non-acoustic spaces, such as a railway concourse or older airport terminals, where announcements are just unintelligible.

The design of low-level systems in auditoria relies on the *Haas effect*. This is the interesting phenomenon that the location (direction) of a source is perceived as the origin of the first sound that reaches the listener. If the same sound arrives with a delay of 10–30 ms, the total sound energy is perceived as if it were coming from the direction of the first. This happens even if the second sound is much stronger than the first.

### Example 3.3

The Haas effect is made use of by the system shown in principle in Fig. 3.51, which is a diagrammatic longitudinal section of an auditorium. There are three rows of low level (low power) speakers. If the distance to a listener at C (the A–C distance) is 40 m, sound travel time will be 0.12 s and if the distance from the loudspeaker at B (the B–C distance) is 7 m, the travel time will be 0.02 s, so the time difference is 0.1 s. The delay system must provide this plus the intended delay of (say) 0.015 s, a total of 0.115 s (115 ms).

**Fig. 3.52**

A rotating magnetic disc time delay system.

Deliberate time delays in the past were created by a rotating magnetic disc (Fig. 3.52) with one recording head and several pickup heads, where the angular distance provided the time delay. This is now done electronically. The output of each speaker in such a system should be small enough to avoid interference.

The principle is similar to that of PSALI (Section 2.5.6), i.e. to supplement daylighting so that it is hardly noticeable, the daylight character of the room is maintained. Here the sound reinforcement is provided in such a way that the audience is unaware of it.

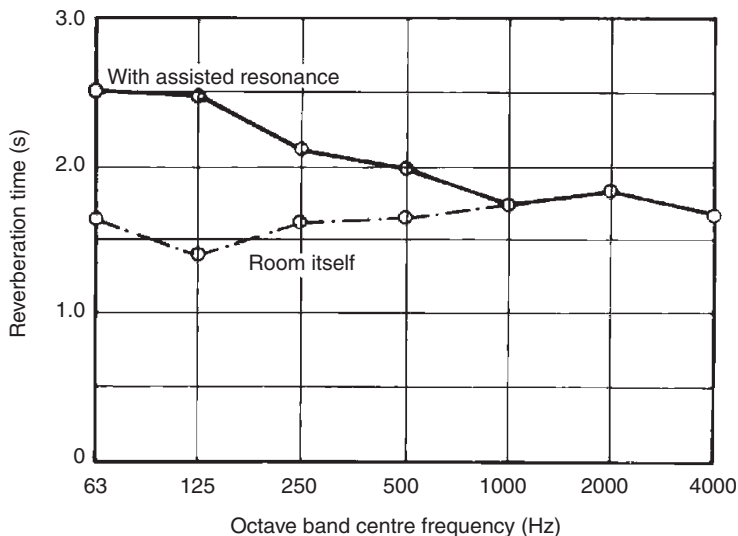
For public address (and background music systems, if you must have one) the low level system is the only satisfactory solution. In auditoria another advantage of such a system is that the contribution of low power speakers to the reverberant field is imperceptible.

**3.4.4.2 Acoustic corrective systems** have been designed to improve the acoustics of some concert halls. The first such system developed for the Royal Festival Hall (London) was euphemistically referred to as an *assisted resonance system* (ARS). This consists of 172 separate channels tuned to very narrow (4 Hz) frequency bands from 20 to 700 Hz (above 700 Hz the room resonance was satisfactory), each consisting of the following components:

- a condenser microphone in a resonant box or tube (with a very narrow frequency response)
- a preamplifier with gain control and delay mechanism and filters to eliminate any harmonics picked up by the microphone in the resonator (a resonator responds to a particular frequency but also to its upper harmonics)
- a 20 W amplifier and
- a speaker of 250–300 mm diameter.

A complex switchboard allows the low frequency resonance to be adjusted and balanced. The hall itself, with its short RT for low frequencies was very good for speech intelligibility, but not for large orchestral music. E.g. in the 125 Hz octave, the room RT is 1.4 s, with the ARS it can be increased to 2.5 s. Fig. 3.53 shows the spectral variation of the RT in the Royal Festival Hall itself and with the ARS operating.

*Multi-channel reverberation* (MCR) systems are now commercially available and often included in the original design of auditoria (and not as 'correction') to produce variable acoustic properties, e.g. for multipurpose halls.



**Fig. 3.53**  
RT in the RFH with and without the ARS operating.

Another kind of 'correction' is the design and use of *masking noise systems*. These have been developed and are used mainly in large 'landscaped' offices. Sounds with information content are much more disturbing than a steady hum. A masking noise can suppress the intelligibility of sounds received, but also gives assurance of aural privacy for people talking and don't want to be overheard. 'White noise' has been used for such purposes, but it has been found that a broad-band sound is more effectively masked by a lower frequency noise. Hence the latest trend is to use a 'pink noise' of a continuous spectrum with a slope of 3 dB per octave (*per analogiam*: pink light: with continuous spectrum, but slightly biased towards longer wavelengths: i.e. a faint red).

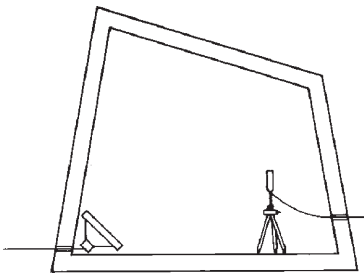
In many practical situations, ventilation or air conditioning diffusers are deliberately designed to give a noise of 45 dB at around 1000 Hz, to give a masking effect, but most often masking noise is produced by a generator–amplifier–speaker system.

**3.4.4.3 Acoustic measurements** are based on a sound level meter, using a condenser microphone. It has a built-in RMS rectifier and a read-out device. It usually has a range selector working in 10 dB increments. The second digit is given by a voltmeter. Most have a set of switchable weighting circuits ('C' weighting is practically linear, see Fig. 3.6). Many have an attached octave band filter (more precise measurements use third-octave filters). The output of such meters may be recorded, graphically, on magnetic tape or electronically. Statistical analysers may produce various noise climate indices, such as those mentioned in Section 3.2.4.

Meters and filters coupled with a CRT can produce a real time spectrogram. Graphic recorders can be used to produce paper versions of the same. Graphic level recorders can be used to measure RT, using either a pistol shot for broad-band measurements or a noise generator with a filter set, producing octave-band noise with a 'no-noise' (clean break) switch for cut off. The latter would produce a decay curve for each octave in sequence (usually eight octaves). This would give the spectral RT values, such as those in Fig. 3.53.

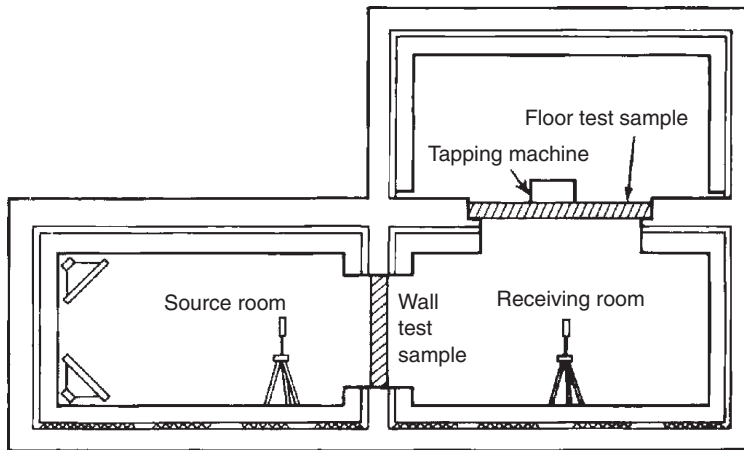
There are two types of acoustic laboratories used for testing the properties of materials, elements or products.

*Reverberant rooms* are used to test the absorption properties of material samples for random incidence, including frequency-dependent absorption coefficients. These must be fairly large compared to the wavelength of the lowest frequency sound used. E.g. the wavelength of a 125 Hz sound is 2.72 m and this would need a room of 180 m<sup>3</sup>. The room must have hard, reflective surfaces, it must be of an irregular shape and include convex, diffusing surfaces, to generate a homogeneous sound field (Fig. 3.54). Here the RT would be measured (both for the empty room and with the



**Fig. 3.54**  
A large reverberant room for absorption testing.





**Fig. 3.55**  
Sound transmission test rooms.

absorbent sample present) and from this the absorption of a sample can be found.

*Transmission test facilities* consist usually of three rooms. These are of very heavy and discontinuous construction, to eliminate flanking transmissions. Two rooms are side-by-side, with a dividing wall of heavy construction, which has an aperture, into which the element to be tested is fitted. Sound generated in the 'source room' is measured in the receiving room, thus the TL or SRI can be established. A third room is often above the receiving room, and the dividing floor has an aperture, into which a floor test sample can be fitted (Fig. 3.55). The noise source will be loudspeakers for airborne transmission and a standard tapping machine to test impact noise transmission.

### 3.4.5 Integration/discussion

The analytical treatment of heat, light and sound and their relationship to humans, pursued above, is only an approach. All three sets of physical influences affect one and the same person. As Gestalt psychology has it, the totality of the experience is what counts. Component effects must be studied to gain an understanding, but *'the whole is more than the sum of its parts'*. The psychological effects and subconscious cross-channel connections are only rarely identifiable, but exist. A few examples would serve as illustration:

- 1 If a room has strong and harsh electric lighting, the noise will be perceived as louder than the same noise in a room with lower illuminance provided by 'warm' lights.

- 2 In a hot climate, a well-shaded dimly lit room will be perceived as cooler than another, at the same temperature but brightly lit.
- 3 A low level of illuminance is relaxing, but work demands higher levels: low illuminance in a work place is soporific.

Even motivation, attitude and personal relationships can influence the perception and response.

- 4 A professor carrying out a thermal comfort survey in an African country got unbelievable questionnaire responses and on further inquiry found that the subjects (his students) were guessing what answers he would expect, as they liked him and wanted to please him.
- 5 The classical example is the *Hawthorn effect* found by Elton Mayo in 1927 at the Hawthorne Works of the Western Electric Company in Cicero (Illinois). Production line workers interpreted environmental improvements as 'care' and 'being looked after', and this affected productivity more than increase in wages. In another factory, with poor work-relations, the same improvements had the opposite effect. The study showed that the effects of environmental changes were mediated by individual attitudes and group processes.

Skinner and the behaviourist school through their experiments with rats may have identified numerous simple stimulus–reaction relationships, but as Sommer (1969) observed, rigorous laboratory experiments are no substitutes for studies of important relationships under natural conditions and field studies. He suggests to leave the single variable laboratory experiments to physics and chemistry. The designer's work is closer to the life-sciences (hence *bioclimatic* architecture) and we would profit more from systematic observation.



# PART 4

## RESOURCES

<b>4.1 Energy</b>	<b>193</b>		
4.1.1 Forms of energy	193	4.2.3 Energy conservation	224
4.1.2 Energy sources	196	<b>4.3 Water and wastes</b>	<b>227</b>
4.1.3 Energy conversion	199	4.3.1 Water	227
4.1.3.1 Cogeneration	202	4.3.1.1 Water supply	229
4.1.3.2 Fuel cells	202	4.3.2 Wastes	231
4.1.4 Renewable energy	203	4.3.2.1 Gaseous wastes	231
4.1.4.1 Wind energy	203	4.3.2.2 Liquid wastes	231
4.1.4.2 Solar energy	205	4.3.2.3 Solid wastes	233
4.1.4.3 Other renewable energy sources	212	<b>4.4 Sustainability issues</b>	<b>233</b>
4.1.5 Energy storage	214	4.4.1 What can architects do?	234
<b>4.2 Energy use</b>	<b>215</b>	4.4.1.1 Site	235
4.2.1 Energy use in general	215	4.4.1.2 Energy	236
4.2.2 Energy use in buildings	217	4.4.1.3 Materials	237
4.2.2.1 Electrical installations	218	4.4.1.4 Wastes	238
4.2.2.2 Gas supply installations	220	4.4.2 Complex rating systems	239
		4.4.3 Economics	241

## Symbols and Abbreviations

g	gravitational acceleration	FSDR	five star design rating
h	height	GPS	general power system
v	velocity	IEA	International Energy Agency
c	velocity of light	LCA	life cycle analysis
ppm	part per million	LPG	liquefied petroleum gas
A	ampere (amp) or area (m <sup>2</sup> )	M	mass
ABERS	Australian building environmental rating system	O	operational energy (pr oxygen)
BMAS	building materials assessment system	OTE	ocean thermal energy
BGR	building greenhouse rating	P	power (W)
C	Coulomb or capital energy	PV	photovoltaic(s)
CHAPS	combined heat and power solar (system)	SSM	supply side management
CHP	combined heat and power	STE	solar–thermal–electric
CoP	coefficient of performance	V	volt
DG	distributed generation	VAWT	vertical axis wind turbine
DHW	domestic hot water	$\alpha$	absorptance
DSM	demand side management	$\eta$	efficiency
E	energy	$\varepsilon$	emittance
EF	ecological factor	$\phi$	phase lag
EMF	electromotive force	$\Omega$	ohm (electrical resistance)

## 4.1 Energy

Energy is the potential for performing work and it is measured in the same unit: J (joule). Energy flow rate is measured by the unit W (watt), which is the flow of 1 J per 1 s (J/s). Watt also measures the ability to carry out work (J) in unit time (s), i.e. power. As energy and work have the same unit (J), power and energy flow rate have the same physical dimension, thus the same unit (W).

An accepted energy unit is the Wh (watt-hour), i.e. the energy that would flow if the rate of 1 W were maintained for 1 h. As there are 3600 s in an hour, 1 Wh = 3600 J or 1 kWh = 3600 kJ = 3.6 MJ. Table 4.1 lists the prefixes used with any SI unit, both sub-multiples and multiples.

A number of other energy units are still in use (some powerful specialised users refuse to adopt the SI), but in this work all these are converted to SI units, to achieve comparability and allow a sense of magnitude of numbers to develop. Some conversion factors are given in Table 4.2.

### 4.1.1 Forms of energy

Energy cannot be created or destroyed (except in sub-atomic processes), but it can be converted from one form to another. Some often encountered forms of energy are reviewed in the present section.

**Heat**, as a form of energy has been discussed at length in Part 1.

Mechanical energy can take two main forms:

**Kinetic energy** is possessed by a body in motion and it is proportionate to the mass of the body (M) and to the square of its velocity (v):

$$E_k = \frac{1}{2}Mv^2.$$

**Table 4.1** Multiple and sub-multiple prefixes for SI units

Sub-multiples				Multiples			
deci	d	10 <sup>-1</sup>	0.1	deca	da	10	10
centi	c	10 <sup>-2</sup>	0.01	hecto	h	10 <sup>2</sup>	100
milli	m	10 <sup>-3</sup>	0.001	kilo	k	10 <sup>3</sup>	1 000
micro	μ	10 <sup>-6</sup>	0.000 001	mega	M	10 <sup>6</sup>	1 000 000
nano	n	10 <sup>-9</sup>	0.000 000 001	giga	G	10 <sup>9</sup>	1 000 000 000
pico	p	10 <sup>-12</sup>	0.000 000 000 001	tera	T	10 <sup>12</sup>	1 000 000 000 000
femto	f	10 <sup>-15</sup>		peta	P	10 <sup>15</sup>	
atto	a	10 <sup>-18</sup>		exa	E	10 <sup>18</sup>	

**Table 4.2** Some obsolete energy units still in use

				kWh
barrel (of oil)	brl	$6 \times 10^9$ J	6 GJ	1 667
tonne oil equivalent	TOE	$4.1868 \times 10^{10}$ J	41.868 GJ	11 630
megatonne oil equivalent	Mtoe	$4.1868 \times 10^{16}$ J	41.868 PJ	$11.63 \times 10^9$
tonne of coal equivalent	TCE		29 GJ*	8 056
kilo-calorie	kcal		4.1848 kJ	1.16
British thermal unit	Btu		1.055 kJ	0.293
calorie (gramme-calorie)	cal		4.1848 J	1.16

\*Some sources use 26 GJ (7222 kWh): it depends on the quality of coal taken as the basis based on International Energy Agency (IEA) Statistics (2002), which uses Mtoe as the basic unit.

An everyday example of such kinetic energy often made use of is the wind. If the density of air is taken as  $1.2 \text{ kg/m}^3$ , and the mass flow rate is

$$M = A \times 1.2v \text{ (m}^2 \times \text{kg/m}^3 \times \text{m/s} = \text{kg/s)},$$

then the power of wind over a swept area A is

$$P_k = \frac{1}{2} \times A \times 1.2v \times v^2 = \frac{1}{2}A \cdot 1.2 \times v^3$$

$$(\text{kg/s} \times (\text{m/s})^2 = \text{kg.m}^2/\text{s}^3 = \text{W}).$$

Therefore, it is said that the power of wind is proportionate to velocity cubed.

**Potential energy** (or positional energy) is possessed by a body which would be free to fall over a vertical distance (height, h), i.e. height relative to a reference level

$$E_p = M g h$$

where g is the gravitational acceleration,  $9.81 \text{ m/s}^2$

$$(\text{kg} \times \text{m/s}^2 \times \text{m} = \text{kg.m}^2/\text{s}^2 = \text{J})$$

An example of such potential energy in everyday use is water in an elevated dam, e.g. with a level difference of 100 m  $1 \text{ m}^3$  (1 kL) of water would have the potential energy

$$E_p = 1000 \times 9.81 \times 100 = 981\,000 \text{ J} = 981 \text{ kJ}$$

and if this  $1 \text{ m}^3$  water flowed in 1 s, it would have a power of 981 kW.

**Chemical energy** is also a relative quantity. Chemical bonding of molecules represents a certain amount of stored energy that was needed to produce that compound from its basic constituents. Chemical operations requiring energy input are termed *endothermic* and those that release energy are *exothermic*. Fuels are compounds with high chemical energy content that can be released by combustion (an exothermic process). Some heat input may be required to start the process (ignition) but then the process is self-sustaining. The energy that could thus be released is the *calorific value* of that fuel, measured in Wh/m<sup>3</sup> or Wh/kg. From the viewpoint of energetics (the science of energy), fuels are referred to as *energy carriers*.

**Electrical energy.** The presence of free electrons in a body represents a charge, an electric potential. These tend to flow from a higher potential zone to a lower one. The unit of electric charge is the coulomb (C). The rate of electricity flow (current) is the ampere (amp, A):

$$A = C/s, \quad \text{conversely} \quad C = A \times s.$$

A potential difference or electromotive force (EMF) of 1 volt (V) exists between two points when the passing of 1 C constitutes 1 J

$$V = J/C.$$

Electric current will flow through a body if its material has free or dislocatable electrons. Metals are the best conductors (silver, copper, aluminium), which have only one electron in the outermost electron skin of the atom. In gases or liquids, electricity may flow in the form of charged particles, ions.

Even the best conductors have some resistance to electron flow. The unit of resistance is the ohm ( $\Omega$ ), which is the resistance that allows the flow of one ampere of current driven by 1 V.

$$\Omega = V/A, \quad \text{conversely} \quad A = V/\Omega.$$

The rate of energy flow in the current (or electric power) is the watt (W)

$$W = V \times A,$$

a unit which is used for all kinds of energy flow.

The above is valid for direct current (DC), i.e. when the current flows in one direction. Alternating current (AC) is produced by rotating generators, where the resulting polarity is reversed 50 times per second, i.e. at the frequency of 50 Hz (in most countries, except in the USA, where it is 60 Hz). With AC, the above relationship is influenced by the type of load connected to the circuit. It is true for a purely resistive load, such as an incandescent lamp or a resistance heater. Here the variations of the current



are synchronous with the voltage variations (Fig. 4.1a). With an inductive load, such as a motor or any appliance incorporating an electromagnetic coil, the current is delayed with respect to the voltage variations (Fig. 4.1c). If one complete cycle is  $360^\circ$ , the delay is measured by the phase angle  $\phi$  and the actual power will be

$$W = V \times A \times \cos \phi.$$

The term  $\cos \phi$  is referred to as *power factor*. If the phase lag is  $90^\circ$ , then  $\cos 90^\circ$  being 0 (zero), there will be no current flowing. This delay can be corrected by introducing a capacitor, which has the opposite effect (Fig. 4.1b). This has been discussed in relation to electric discharge lamps in Section 2.5.1. For this reason, the power of alternating current is referred to as VA or kVA (rather than W or kW).

### 4.1.2 Energy sources

From the eighteenth century onwards, **coal** was the most important energy source, it can be said that our industrial civilisation has been built on coal. Oil production started early twentieth century and with the introduction of the internal combustion engine as used in cars, trucks, aeroplanes but also in stationary applications, its use has rapidly grown. By 1966 oil production exceeded coal (in energy terms) and by 2012 it is expected that gas will also exceed coal.

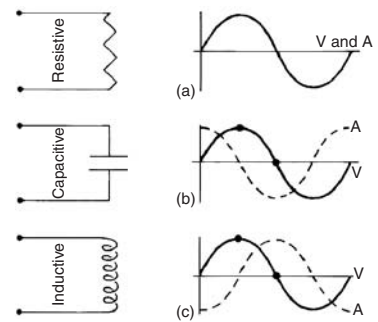
The most worrying fact is that the rate of discovering new oil reserves is rapidly decreasing: from a peak of  $49 \times 10^9$  barrels p.a. (1960) to  $6 \times 10^9$  (1995). Fig. 4.2 shows the world's energy supply by region, comparing the 1997 data with the forecast for 2020 and Fig. 4.3 indicates the growth of primary energy supply since 1970, with projection to 2020, by form of fuel.

**Oil** production by regions is shown in Fig. 4.4, as well as the total, from 1930 to the middle of this century. Demand will exceed supply and production will decline. This is referred to as 'rollover', i.e. from a buyer's market to a seller's market. Such rollovers have already occurred in some regions, e.g. around 1970 for the USA and Canada, and in 1986 for the UK and Norway. The 'big rollover' on the world scale is forecast by some for 2020 and the International Energy Agency (IEA) predicted (in 1998) that it will occur 'between 2010 and 2020'.

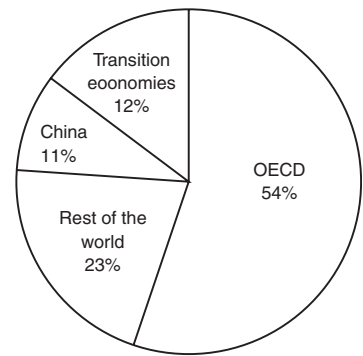
The present consumption of energy in the form of oil is  $118 \times 10^9$  kWh (71 million barrels) in a day (!)

$43 \times 10^{12}$  kWh (26 billion barrels) in a year.

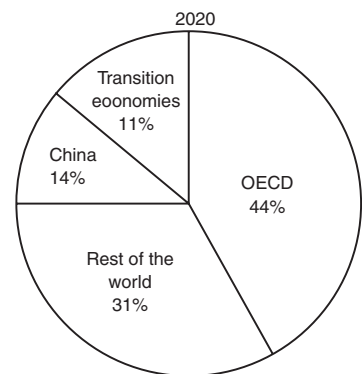
The oil stock of earth is estimated as  $1.6 \times 10^{15}$  kWh (960 billion barrels) (Fig. 4.5).



**Fig. 4.1** Resistive, capacitive and inductive loads and their effect on current.

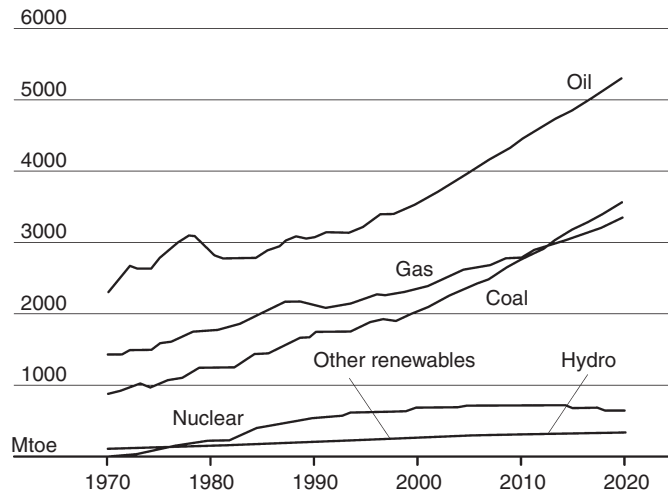


8610 Mtoe  
= 360.48 EJ  
=  $100.13 \times 10^{12}$  kWh

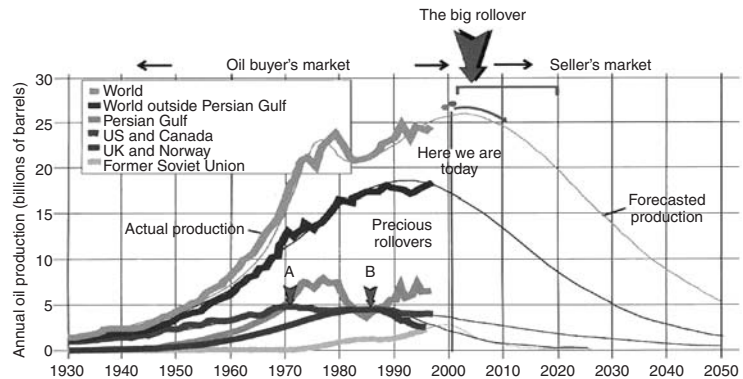


13 529 Mtoe  
= 566.43 EJ  
=  $154.34 \times 10^{12}$  kWh

**Fig. 4.2** World energy supply, by region: 1997 data and 2020 forecast.



**Fig. 4.3**  
World primary energy production in Mtoe (each curve to be read from the base line). Note that the Hydro and Renewable curves overlap. IEA: World Energy Outlook, 2000.



**Fig. 4.4**  
History and forecast of world (and regional) oil production. A = USA and Canada, B = UK and Norway. Source: Aus. Energy News, Dec. 2001.

Dividing the annual consumption into the stock gives the 'static index', which means that if the present rate of consumption is continued, the stock would be exhausted in 37 years. This is unlikely to happen. As supplies diminish, oil prices will increase. This, on the one hand, will reduce consumption and, on the other hand, it will make competitive the renewable energy alternatives (some of which are now too expensive). A similar 'rollover' for coal is predicted for the middle of the twenty-second century. The even

greater worry is that coal and oil are not only our primary energy sources, but also the raw materials for many of our chemical industries.

The only other practical sources are nuclear and renewable energy. The latter will be the subject of Section 4.1.4; the former is briefly discussed in the following.

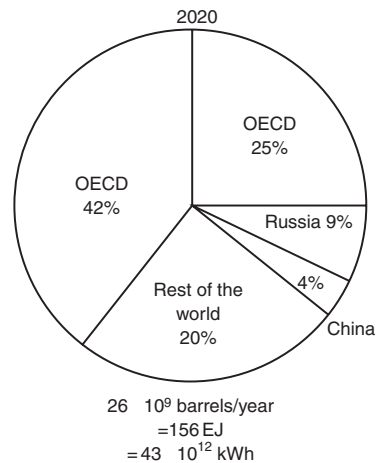
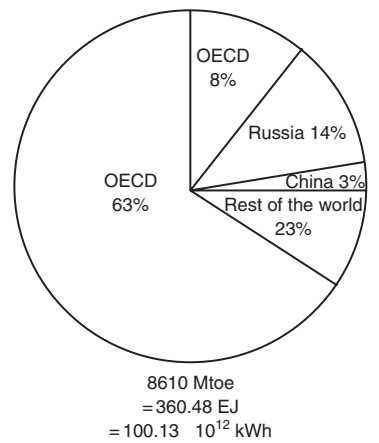
**Nuclear energy** is in fact a very primitive use of a tiny part of a fissionable material converted to thermal energy to produce heat, to generate steam and drive an ordinary steam turbine.

When certain fissionable atoms, such as uranium 235, are split as a result of bombardment by neutrons, the total mass of fission products is slightly less than the mass of the original atom (by about 0.1%). The lost mass is converted into energy, according to Einstein's expression  $E = M \times c^2$  (where M is mass in kg and c is the velocity of light:  $3 \times 10^8$  m/s). Some neutrons are also released which will split other atoms, thus a chain reaction is produced. The neutrons are slowed down and the process is controlled by the insertion of carbon (in the form of graphite) rods between the fuel rods.

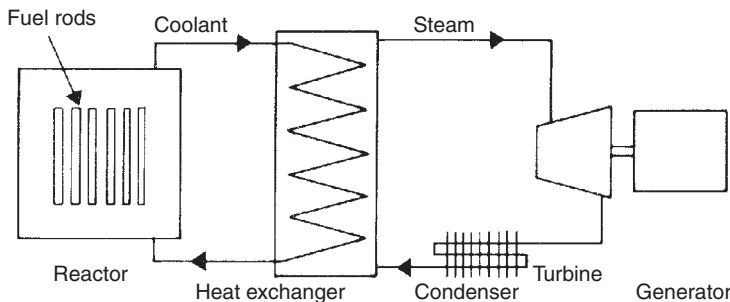
The energy released is in the form of heat and it is removed by a coolant. The circulating coolant will give off its heat through a heat exchanger to water, generate steam, which will drive the turbine. A schematic diagram of the system is shown in Fig. 4.6.

There are many different types of nuclear reactors and all produce radioactive waste material. The disposal of this has not yet been satisfactorily solved. Huge amounts of such wastes are in 'temporary' storage: some of this remains radioactive for hundreds of years.

Nuclear energy is less than 1% of the national total primary energy consumption in both the UK and the USA. This would correspond to over 7% of electricity produced in the UK and some 4% in the USA. According to the IEA statistics, Lithuania is the country most heavily relying on nuclear energy for electricity



**Fig. 4.5** World oil reserves and present rate of production, by region.



**Fig. 4.6** System diagram of a nuclear power station.

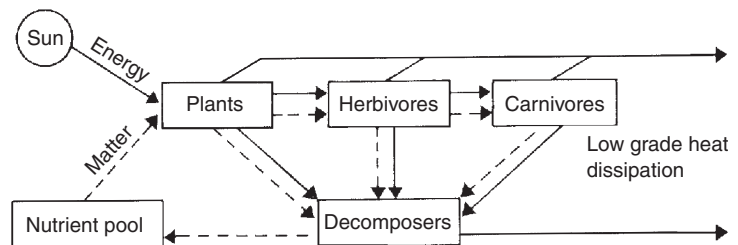
generation (75% – an inheritance from the Soviet era), Belgium is second with some 56% , but in absolute terms both are quite small. France is the largest producer of nuclear electricity, with a capacity over 60 GW. Worldwide there are some 430 nuclear plants in operation in 31 countries, some 50 new plants are under construction and more than 70 have already been closed down for reasons of various failures but their dismantling is delayed because of problems of radioactivity. Many countries (e.g. Germany) decided not to have any further nuclear plants and to progressively phase out existing ones.

#### 4.1.3 Energy conversion

The dominant energy conversion process on earth is photosynthesis, which converts the electromagnetic radiation of the sun into plant material. Photosynthesis by plants and algae is the basis of the food chain for all animals: herbivorous, carnivorous and the biggest carnivores: humans.

Fig. 4.7 is a very simple and schematic representation of the food chain, but it is sufficient to demonstrate that the material content of living beings may be recycled, but energy only flows in one direction: 'downhill', from high energy electromagnetic (solar) radiation to very low grade heat produced by decomposers and is ultimately dissipated, re-radiated by earth into general space. This photochemical conversion produces all the biomass (wood and plant material) and had, over the geological time scale, produced all our fossil fuels. The thermal effects of solar radiation drive the terrestrial climate system, cause winds and the hydrological cycle, which we may tap and utilise.

The most important conversion processes we make use of are chemical-to-thermal, thermal-to-mechanical, mechanical-to-mechanical (e.g. pressure to rotation) and mechanical-to-electrical. Fire is the oldest form of *chemical-to-thermal* conversion, but all our thermal engines are based on this, either by generating steam to drive reciprocating engines or turbines, or by internal combustion



**Fig. 4.7**  
Flow of energy and matter in ecosystems.

engines of various kinds. Such *thermal-to-mechanical* conversions drive most of our transport system as well as electricity production, via *mechanical-to-electrical* conversion. (The generation of electricity involves a triple conversion: chemical-thermal-mechanical-electrical.)

Numerous other conversion processes are made use of on a smaller scale (but some of these are of an increasing importance). Solar cells convert *radiant-to-electrical* energy by photovoltaic processes. Thermoelectric cells convert *heat-to-electricity* directly. Dry cell batteries and fuel cells convert *chemical-to-electrical* energy.

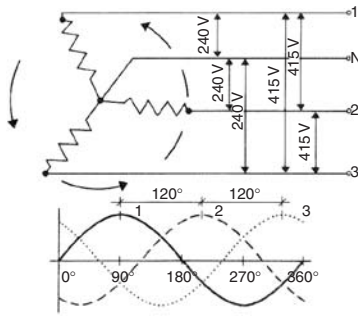
**Electricity** is by far the most convenient form of energy, which can be used for any and all of our everyday purposes. Motors of various kinds can produce mechanical energy and work. Electric lamps can produce light. Electricity drives our communications systems and our computers. Without electricity all our cities would come to a standstill—modern life is just unthinkable without electricity. Electricity can even be used to produce other energy carriers, notably gaseous or liquid fuels, by *electrical-to-chemical* energy conversion, e.g. hydrogen generation.

Electricity is generated primarily by thermal power stations: turbines driving the generators. Hydroelectricity generation is significant in some countries where the geography ensures large amounts of water to be available at high elevations (with large level differences) to drive water turbines (positional-mechanical-electrical energy conversion).

Electrical conversion processes are of a very high efficiency, but the generation of electricity, the conversion of other forms into mechanical work, is very inefficient. Table 4.3 presents a summary of various conversion efficiencies.

**Table 4.3** Conversion efficiencies of various processes

Conversion	Device	Efficiency, $\eta$
Chemical-to-heat	Open fireplace	0.30
	Coal fired boiler, manual feed	0.60
	Coal fired boiler, automatic	0.70
	Oil fired boiler	0.70
	Gas fired boiler	0.75
Heat-to-mechanical	Steam piston engines	0.05–0.20
	Steam turbines	0.18–0.40
Chemical-to-mechanical	Petrol engines	0.20–0.28
	Diesel engines	0.32–0.38
	Gas turbines	0.30–0.35
Electrical	AC generator	0.97
	AC motor	0.92
	Transformer	0.98
	Lead–acid battery (input–output)	0.75
	Electric heating	0.99



**Fig. 4.8**  
Generation of 3-phase electricity supply.

Most electricity is produced in the form of AC, as the voltage of this can easily be converted up or down by transformers. Fig. 4.8 shows the principles of 3-phase generation, in this case a 240/415 V supply (phase-to-phase 415 V, phase to neutral 240 V). For the transmission of 3-phase supply, four conductors are required. If the load is well balanced between phases, the neutral can be quite small and sometimes it is omitted (connected to earth). Normally for a single phase supply two conductors are used. For small supplies over long distances, sometimes a SWER system is relied on: single-wire-earth-return.

The necessary cable size is determined by the current to be carried. If the current is too large for a given conductor, it will be heated, causing a loss of power. To transmit a given power with a high voltage, the current will be smaller, thus a smaller cable can be used. Therefore, a higher voltage is used for long distance transmission. The normal supply voltage in the UK and Australia is 240 V, in the USA 110 V. In continental Europe, 220 V is most frequent and in Japan 100 V is the most usual supply. The local distribution network is usually at 11 kV (11 000 V). The primary distribution network in the UK operates at 132 kV, but the national grid uses 275 kV. For long-distance transmission (in the ‘super-grid’), 400 kV is used. In Australia, for long-distance transmission, 132 and 330 kV lines are used, while some still operate at 66 kV and some new lines operate at 500 kV.

The cost of electricity shows wide differences across the world. In rural and remote areas, it is usually more expensive. Table 4.4

**Table 4.4** Average cost of electricity in various countries

In US ¢	Residential (¢/kWh)	Industrial (¢/kWh)
Japan	21	14
Germany	17	8
Spain	14	6
Italy	13	9
Belgium	13	5
Portugal	12	7
France	10	4
UK	10	5
Ireland	10	5
USA	9	4
Finland	8	4
Australia	8	6
Greece	8	4
Korea (Sth)	7	6
Canada	6	4

Source: Aus. Energy News. Sep. 2001 corrected by IEA 2002.

compares average supply prices in some countries for residential and industrial use (in large urban areas).

**4.1.3.1 Cogeneration**, also referred to as Combined Heat and Power (CHP) is based on the second law of thermodynamics, namely that the production of mechanical work from heat is an inherently low efficiency process and that the thermal energy must flow from a source to a sink and only part of this flow can be converted into work. Electricity generation by heat engines will only be some 33% efficient. The remaining 67% is waste heat, in the past dissipated into the environment: the atmosphere or water bodies. Depending on the situation, on the local heat demand, up to 75% of the available heat (i.e. 50% of the fuel energy) can be utilised, resulting in up to 80% overall efficiency. Table 4.5 summarises the efficiencies and CO<sub>2</sub> emissions of various generating systems.

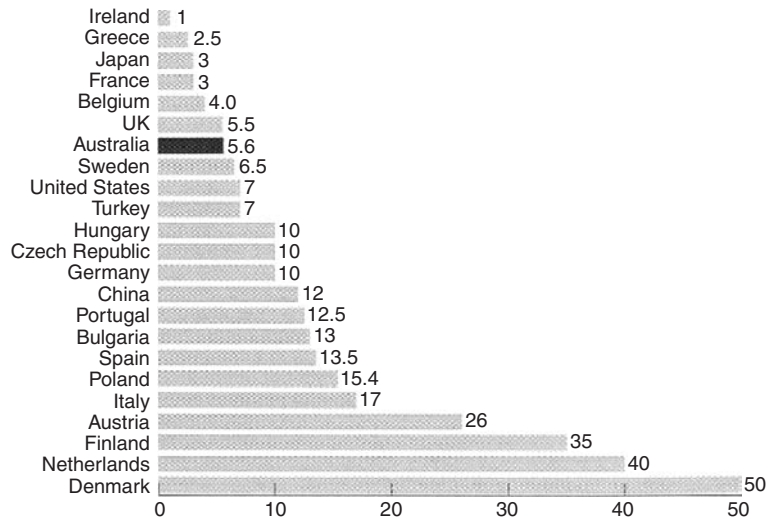
Until recently, only large-scale systems proved to be economical, but in the last two years several small-scale units have been introduced. There is an LPG-operated unit, the size of a bar-refrigerator, which can provide 3.7 kW of electricity and heat at the rate of 8 kW. It is referred to as a general power system (GPS). In some countries cogeneration is already a very substantial part of the total electricity production, e.g. in Denmark, it reached 50% (see Fig. 4.9). In the UK, over 150 CHP plants contribute about 5% of the national total electricity production. In Australia some 130 plants exist, with an aggregate output of 1500 MW (most of these are in the 1–10 MW range) and a similar capacity is now being installed.

**4.1.3.2 Fuel cells** were first constructed around the middle of the nineteenth century, but it is only recently that they became practical sources of electricity and are increasingly used. A fuel cell is essentially a device that converts the chemical energy of some fuel directly into electricity. In principle, it is similar to the dry-cell battery, but while in the latter the finite quantity of ingredients are built in, in the former the fuel and oxygen are supplied continuously. Fuel cells are used in spacecraft, with liquid hydrogen and

**Table 4.5** Efficiency and emissions of generating systems

	Fuel type	Overall efficiency(%)	CO <sub>2</sub> emission (kg/kWh)
Conventional	Thermal: brown coal	29	1.23
	Thermal: black coal	35	0.93
	Thermal: natural gas	38	0.49
	Gas turbine (330 MWe)	48	0.39
Cogeneration	Gas (40 MWe)	72	0.29
	Gas (120 MWe)	77	0.26

Source: Aus. Cogen. Assoc. paper 4.



**Fig. 4.9**

Cogeneration as a percentage of total electricity production in some countries.

*Source:* International CoGen Alliance, 2000.

oxygen input, using platinum electrodes. In terrestrial applications, methanol, petroleum products, natural gas and LPG can serve as fuel, relying on air as oxidant.

Today various fuel cells are commercially available in sizes from 1 kW to some 200 kW. Some are suitable for cogeneration, i.e. the heat produced can also be utilised. Such CHP fuel cell systems have achieved over 70% efficiency. In most modern fuel cells, the electrodes are porous metal or carbon structures and some form of catalyst is used. Recently the Australian Commonwealth Scientific and Industrial Research Organisation (CSIRO) developed a ceramic fuel cell using natural gas as fuel. The development of cars powered by fuel cell-operated electric motors are at the prototype stage and large-scale production is expected in a few years' time.

#### 4.1.4 Renewable energy

The term includes all energy sources which are not of a finite stock, but which are continually available. This would include solar and wind energy and hydroelectric systems, as well as others, such as geothermal or tidal energy, biomass and methane generation. Table 4.6 shows the contribution of renewable sources to the world energy use.

**4.1.4.1 Wind energy** seems to be at present the most competitive of the renewable alternatives and the most widely used

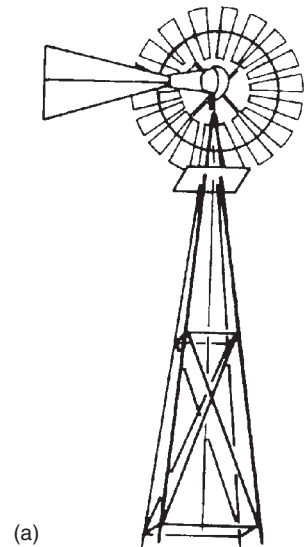


**Table 4.6** The share of renewables (2002 data)

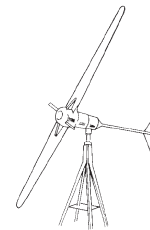
Total primary energy supply	$124.475 \times 10^{12}$ kWh	%
Of which renewable sources contribute	$17.15 \times 10^{12}$ kWh	13.8
Of this		
Hydro		16.5
Solar, wind, geothermal		3.7
Combustibles (firewood, wastes, etc.)		79.8

(perhaps with the exception of domestic solar water heaters). Apart from the traditional windmills, slow moving devices having large ‘sails’ (e.g. in Crete and in the Netherlands, but used already in China and Babylon over 2000 years ago). Two types of wind devices have been used for well over a hundred years, those with horizontal axis and those with vertical axis. In the horizontal axis types we have high solidity rotors (Fig. 4.10a) (i.e. the frontal view of the rotor is almost all solid) used primarily for water pumping and the low solidity (propeller) type, used for electricity generation (Fig. 4.10b). In the vertical axis type we have the high solidity Savonius rotor (Fig. 4.11a) and the low solidity rotors, developed by Darreius, also referred to as ‘egg-beaters’ (Fig. 4.11b). Up to the 1970s, most propeller-generators were in the order of 1–2 kW and since then this type became the most developed into large units, 500 kW to 1.5 MW sizes. The largest one so far is the Nordex N80 unit, with a rated output of 2.5 MW and a rotor radius of 80 m.

The installed wind generating capacity in the world has increased from less than 1 MW in 1980 to almost 16 GW in 2000

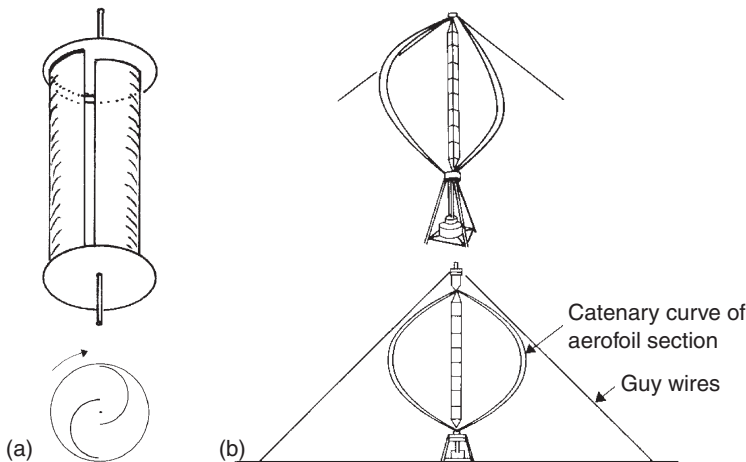


(a)

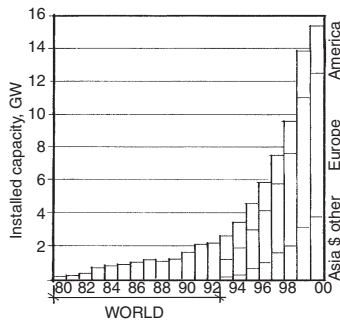


(b)

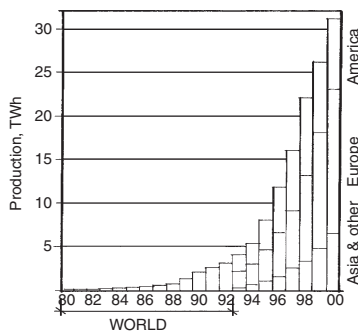
**Fig. 4.10**  
(a) A high solidity pumping windmill. (b) Propeller type wind generators (aerogenerators).



**Fig. 4.11**  
(a) The Savonius rotor. (b) The Darreius rotor.



**Fig. 4.12**  
World wind generating capacity (by regions after '93).



**Fig. 4.13**  
World wind electricity production  $10^9$  kWh (TWh)  
Source: Aus. Energy News, Dec.'98.

(see Fig. 4.12) and the electrical energy produced has grown from 1 GWh to 16 TWh ( $10^{12}$  Wh) p.a. (Fig. 4.13). In the UK, there are operating wind generators with a total output of 422 MW (2001 data), current and planned projects will bring this up to 2000 MW capacity. The UK target is that, by 2010, renewables should contribute 10% of the total electricity production.

*WindForce10*, an international alliance set the target for 2020: 20% of all electricity produced should be by wind generators. The Australian target is very conservative: only 2%, although the Federal Senate voted to increase the Mandatory Renewable Electricity Target (MRET) to 5% by 2020, the government is still undecided.

Recently a new vertical axis wind turbine (VAWT) became available, which is suitable for roof mounting; a low solidity device, serving the individual consumer. It is available in 1.2–2 kW outputs, with 0.8–1.5 m diameter and with suitable current conditioning, it may be used as a grid-connected device. (A stand-alone system would need back-up storage batteries to ensure availability of power when there is no wind.)

The 'world's largest' wind farm operates at King Mountain, near McCamey, Texas, which consists of 160 turbines, each of 1.3 MW capacity, a total of over 200 MW. Apparently, Texas legislation requires that 1.5% of electricity be produced from renewable sources by 2003, rising to 3% by 2009.

There seems to be a much smaller, but significant market for small wind turbines. The above-mentioned VAWT is a good example, but three others should be mentioned:

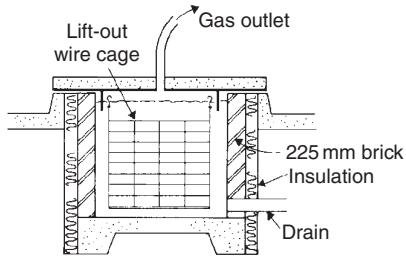
- 1 'Air 403' of Southwest Windpower of the USA, 400 W, 1.15 m diameter with three narrow blades.
- 2 'Rutland 913' of Marlec, UK, 90 W, 0.9 m diameter, with six blades.
- 3 'Enflo Systems 0060/05' of Switzerland, 500W, a 5-bladed rotor of 0.6 m diameter, within a 0.8 m diameter tubular diffuser.

All three are rated with a 12.5 m/s wind speed and all three can be grid-connected with a suitable inverter and power conditioner.

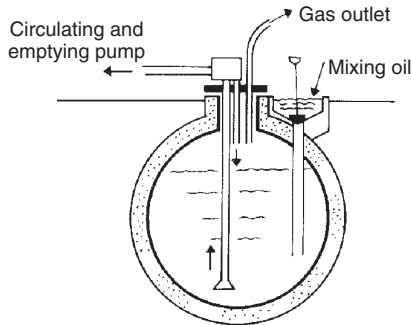
**4.1.4.2 Solar energy** is the driving force of all terrestrial energy systems. Indeed, all plant material and living body matter, all oil, gas and coal are in fact accumulated solar energy. Here the present day direct use of solar energy is to be discussed.

It has been shown that, in Australia, salt production uses more solar energy than all other applications put together: the evaporation of sea-water from shallow ponds, with the salt being left behind and scraped up with heavy machinery. Other direct uses of solar energy may include thermal, electrical and (bio-) chemical conversion. The last one is often referred to as biomass conversion.

**Biomass conversion** may include the use of agricultural *by-products* (e.g. sugarcane bagasse used to fire boilers) or the growing of *energy crops*, e.g. rape-seed, the oil of which can be used as



**Fig. 4.14**  
A Methane generator for solid input.



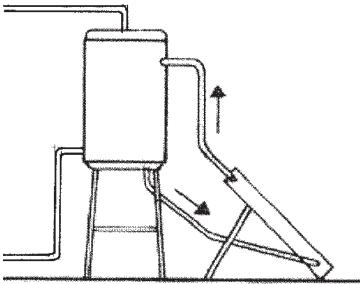
**Fig. 4.15**  
A Methane generator for liquid input.

substitute for diesel oil, or sugar fermentation to produce ethanol as a petrol substitute.

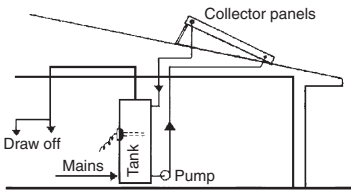
**Methane gas** ( $\text{CH}_4$ ) generation can be considered as biomass conversion. Essentially this is the anaerobic digestion of farm by-products, e.g. straw and manure. The *carbon–nitrogen ratio* of the feedstock is important. Too much carbon (plant matter) will produce much  $\text{CO}_2$  and little  $\text{CH}_4$  (Figs 4.14 and 4.15). Some manure will help to restore the C/N ratio to the optimal 25–35. The methane generated is easily stored (e.g. in gasometers) and can be used in burners. Large-scale use is possible in sewage treatment plants, where enough methane may be generated and collected to produce steam, to drive turbines and generate electricity in the order of tens of MW.

A recent development is the capture and use of methane generated in waste dumps. The dump, when full, can be covered by a polythene film, before the usual layer of earth is put on. Significant amounts of gas may be collected over many years and used for electricity generation.

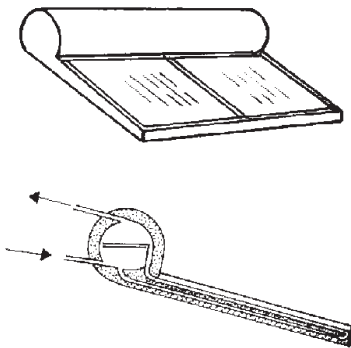
These systems have the added benefit of reducing the greenhouse effect. Methane is a greenhouse gas with an effect about 40 times as great as  $\text{CO}_2$  (partly because it persists much longer in the atmosphere). It would be produced anyway and dissipated into the atmosphere. If it is oxidised (burnt), it is reduced to water and some  $\text{CO}_2$ .



**Fig. 4.16**  
A thermosiphon solar water heater.



**Fig. 4.17**  
A pumped solar hot water system.



**Fig. 4.18**  
A close-coupled solar water heater.

In **thermal applications**, the simplest conversion system is the flat plate collector, which can be used for low-temperature (<100°C) thermal purposes: water heating or air heating. This is a metal panel (usually copper) with some waterways (either a tube-grid or channels formed between two sheets) or air ducts, with a black surface (in better products a selective surface: high  $\alpha_{\text{solar}}$  but low  $\varepsilon$  (<100°C), insulated backing and a glass cover. If the water tank is mounted higher than the collector, a thermosiphon circulation will develop (Fig. 4.16), the tank of water will be heated. If the collectors are on the roof and the tank at floor level, a small pump must be relied on to circulate the water (Fig. 4.17).

Most systems would have an electric immersion auxiliary heater, for use during inclement weather. Close-coupled systems have a horizontal cylindrical tank at the top edge (Fig. 4.18, see also Fig. 1.101). Many different systems are available, classified according to pressure, circulating system and the form of auxiliary heater.

The use of such solar water heaters is mandatory for domestic hot water (DHW) systems in some countries (e.g. Israel), encouraged by tax rebates (e.g. in the USA) or attract a government subsidy of about 30% of the cost (e.g. in Australia). It is suggested that such support is necessary to restore the 'level playing field', otherwise distorted by the many hidden supports conventional energy systems receive from governments.

Solar-thermal systems may be classified as *active* or *passive*. There is no sharp distinction, but the following boundaries have been proposed according to system coefficient of performance (CoP):

- passive system, if  $\text{CoP} > 50$
- hybrid system, if  $20 < \text{CoP} < 50$
- active system, if  $\text{CoP} < 20$ ,

$$\text{where } \text{CoP} = \frac{\text{energy of solar origin delivered}}{\text{parasitic energy used}}$$

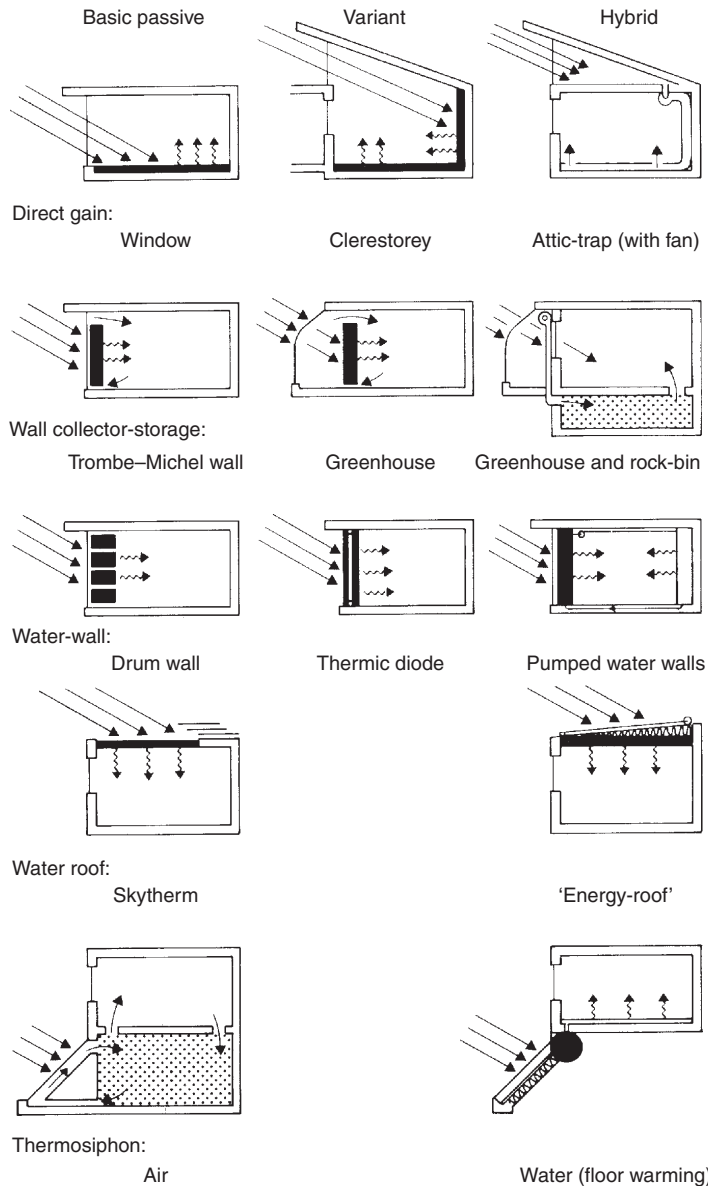
and parasitic energy is that used by pumps, fans and controls to drive the system.

Clearly, the thermosiphon DHW system is 'passive', but solar DHW systems have an auxiliary (booster) heater, which is still responsible for significant greenhouse gas emissions, as shown in Table 4.7.

Fig. 4.19 shows a range of passive systems used in buildings. This type of systematic categorisation was fashionable 20 years

**Table 4.7** Greenhouse gas emissions of DHW systems

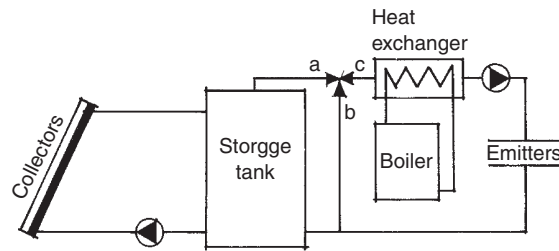
	Warm climate	Cool climate (tonne/year)
Solar, with gas booster	0.3	0.5
'Five star' gas heater	1.3	1.6
'Two star' gas heater	1.6	
Solar, electric booster	1.2	1.9
Electric	4.8	



**Fig. 4.19**

Main types of passive solar heating systems.

- 1 The direct gain window and clerestory are not more than a correctly oriented window and some mass in the floor or wall to absorb and store the solar heat.
- 2 The Trombe-Michel wall and solar greenhouse have been discussed in Section 1.5.1.1.
- 3 The drum wall uses water in drums as the heat storage. The 'thermic diode' circulates water by thermosiphon from the outer collector to the inner storage tank in a clockwise direction; a non-return valve at the top stops reverse circulation.
- 4 The skytherm roof is some 200 mm of water in bags; winter: covered by insulating panels at night, exposed to solar input during the day; summer: exposed at night to dissipate heat by radiation to the sky, covered during the day to provide a cool ceiling.
- 5 The thermosiphon air system uses a rock bed heat storage. The water system has a pumped emitter circuit to warm the floor.



**Fig. 4.20**

A solar space heating (active) system with an auxiliary boiler. By turning the 3-way valve into the b-c position, it becomes a conventional central heating system, whilst the solar collector circuit may operate independently.

ago. Now we consider the distinction between a ‘passive solar system’ and a thermally well-designed building as almost impossible. All houses are potential solar collectors, their success or failure depends on the design. Indeed some of these systems have been discussed in Section 1.5.1.1 in the context of thermal design of buildings, under the heading of passive control of heat flows.

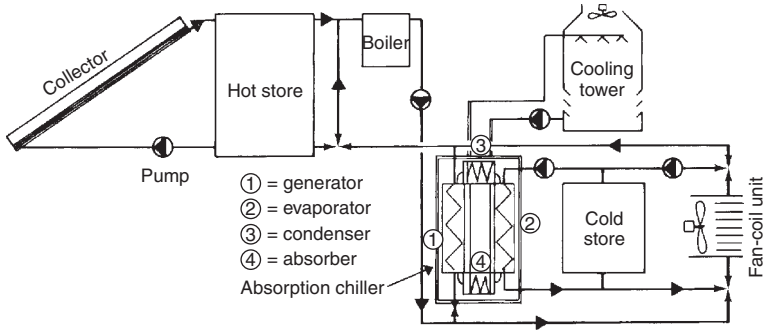
Whilst DHW systems may use 2–6 m<sup>2</sup> flat plate collectors, collector arrays an order of magnitude greater may be used for space heating or industrial process heating purposes. These are bound to use pumps, both in the collection and heat delivery circuits, and are thus in the category of ‘active systems’. Fig. 4.20 is the system diagram of a domestic space heating installation. The emitter may be either a panel radiator or a fan-coil unit.

Fig. 4.21 shows a solar air conditioning system based on an absorption type (LiBr/H<sub>2</sub>O: lithium bromide/water) chiller system (H<sub>2</sub>O is the refrigerant and LiBr is the absorbent).

For best performance, the tilt angle of solar collectors should be the same as the latitude (this would receive the most beam radiation, whilst a lesser tilt would receive more of the diffuse radiation), but may be biased for the dominant need: steeper for winter heating and flatter for summer cooling.

Solar collectors may use air as the heat transport fluid and fans to drive the circulation instead of pumps. Such solar air systems are often used for space heating (one advantage is that there is no risk of freezing overnight), but also for many industrial purposes, such as crop drying or timber drying. A crushed rock (or pebble) bed can be used as heat storage. Fig. 4.22 shows a solar air heating system and its ductwork.

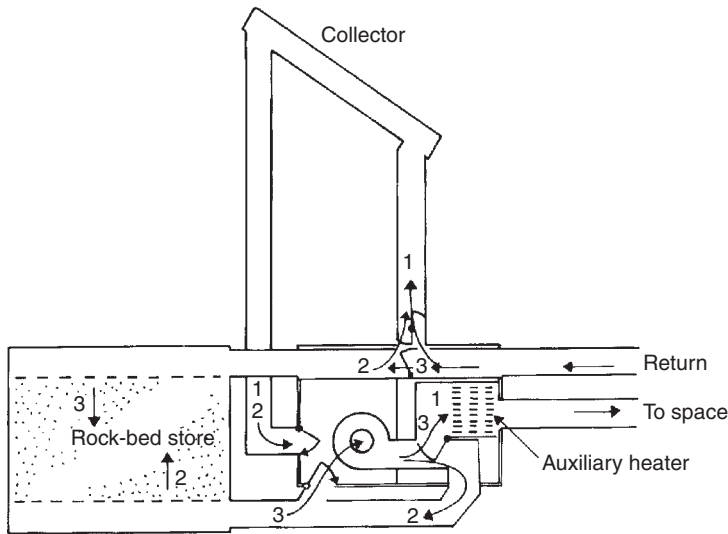
The best flat plate collectors can heat water (or air) to over 90°C, but much higher temperatures can be produced by concentrating collectors. These all use some mirror, either as a single curvature parabolic trough or as a double curvature ‘dish’. The former has a linear focus, the latter a point (or near-point) focus. These usually operate at 500–800°C temperatures and can produce superheated



**Fig. 4.21**

A solar powered air conditioning system.

- 1 The collection circuit is: collector–hot store–pump.
- 2 The heating circuit is: hot store–(possibly boiler)–pump–fan–coil unit and back to store.
- 3 The chiller circuit is: hot store–(possibly boiler)–pump–absorption chiller generator ① and back to store.
- 4 The chilled water circuit is from evaporator ② (possibly cold store) to fan-coil unit and back; if there is no cooling demand, the cold store is cooled. If there is no sun, any cooling demand is satisfied from the cold store.



**Fig. 4.22**

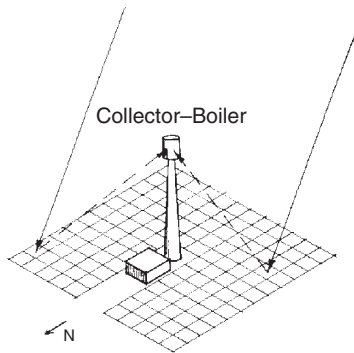
A solar space heating system using air as the heat transport fluid.

- 1 Collector to space circuit (possibly auxiliary heater)
- 2 Collector to rock-bed heat storage
- 3 Storage–(possibly auxiliary heater)–to space

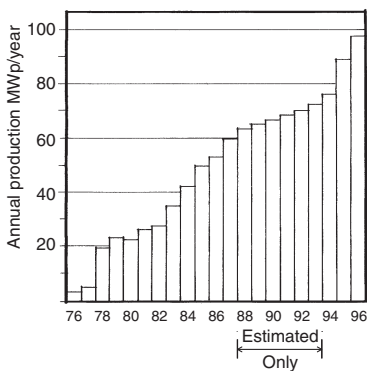
The heavy outline indicates a prefabricated unit containing the fan, the auxiliary heater and all dampers.



**Fig. 4.23**  
A field of parabolic troughs connected to a central boiler/generator house.



**Fig. 4.24**  
A 'power tower' system: a field of mirrors with a central tower-mounted receiver/boiler and a generator house.



**Fig. 4.25**  
PV module production of the world since 1976.

steam. Areas of several hectares may be covered by such collectors for the purposes of electricity generation. These are often referred to by the generic term STE or solar-thermal-electricity systems. Fig. 4.23 is a diagram of a field of parabolic troughs with a central boiler/turbine house.

A particular STE system is referred to as the 'power tower', which has a large field of individually steerable mirrors, all focused on a central receiver mounted on top of a tower (Fig. 4.24). Large-scale prototypes of both the power tower and a field of parabolic troughs have been built both in California and for the EU in Spain and feed electricity into the grid.

STE generators are all high temperature systems. At the other end of the scale are the **solar ponds**. These are large area, inexpensive solar collectors. When a pond of water is heated, the warmest water comes to the surface (being lighter) and rapidly dissipates its heat by convection and evaporation, then it sinks. An undesirable thermosiphon circulation develops. This can be prevented by using very salty water for a bottom layer and a fresh water upper layer. The salty water, even at near boiling-point temperatures, is heavier than the fresh water and remains at the bottom. Water can be circulated through a pipe coil and the heat thus recovered can be used to drive some heat engine, possibly even a turbine, where the working fluid may be some low boiling-point organic fluid.

**Photovoltaic (PV) cells** are used for direct conversion to electricity, relying on some semiconductor. The most widely used ones are silicon cells, which may be single crystal (grown as a cylinder and sliced into thin wafers), polycrystalline or amorphous silicon. Single crystal cells in commercial production exceeded 24% conversion efficiency, but polycrystalline cells, with their 15–19% efficiencies are much less expensive. These have been used in large arrays, mounted on a framework at ground level, but recently the building-integrated PV systems became widely used. Several governments have large-scale programmes. Germany launched its 'thousand solar roofs programme' some 10 years ago and a follow-up 100 000 solar roofs programme is in progress. The USA launched its 'million solar roofs' programme (although that includes flat-plate thermal collectors). Australia gives a direct subsidy of \$5 per Wp (peak watt) to any domestic scale PV installation.

Fig. 4.25 shows the growth of annual PV module production of the world since 1976. The cost of such modules moved in the opposite direction: in 1974 it was about US\$ 120 per Wp, and now it is around \$5–6 per Wp.

Whilst silicon solar PV cells dominate the present day market, many other semiconductors produce a photovoltaic effect and have been used experimentally, such as

- |                   |      |
|-------------------|------|
| Gallium arsenite  | GaAs |
| Cadmium sulphide  | CdS  |
| Cadmium telluride | CdTe |



Germanium Ge  
Selenium Se

Today there are some promising developments in other directions. Titanium oxide (TiO<sub>2</sub>) cells, using an organo-metallic dye are said to be much cheaper and produce an output higher than the Si cells, especially at low levels of irradiance. Thus, they can be used for indoor purposes also.

A Combined Heat and Power Solar (CHAPS) system has been developed at the Australian National University (ANU) for domestic use. It has two shallow parabolic mirrors (2 m<sup>2</sup> each) with a double-axis tracking system and a row of PV cells at the focal line, which are water cooled by pumped circulation. This contributes hot water to a solar DHW system and generates electricity. The output of PV cells would be drastically reduced at elevated temperatures; this system avoids such overheating. The peak output of the system is 700 W.

A US DoE report shows that in 1999 the world total renewable energy production (in kWh) was  $227 \times 10^9$  kWh and the largest producers were:

- USA:  $83 \times 10^9$  kWh
- Japan:  $25 \times 10^9$  kWh
- Germany:  $15 \times 10^9$  kWh
- Brazil:  $10 \times 10^9$  kWh
- Finland:  $10 \times 10^9$  kWh

Over the last 9 years, the growth rate was 6.5% p.a. in the USA, but over 30% in the EU countries.

There are many other forms of utilisation of solar energy, which are not of direct interest to architecture. Table 4.8 attempts to summarise most technologies and purposes of using solar energy in direct or indirect form.

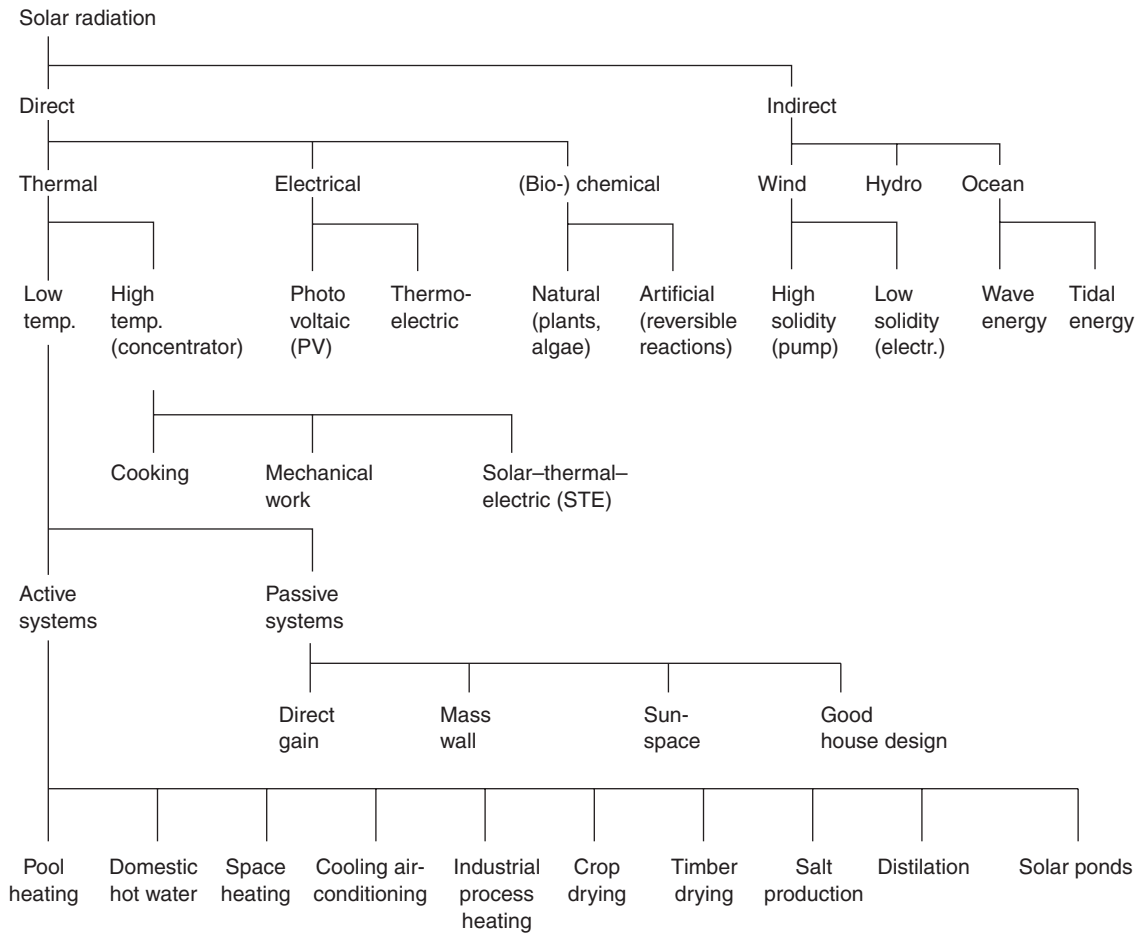
**4.1.4.3 Other renewable energy sources** are also available and systems for their utilisation are in various stages of development.

**Ocean energy** may be utilised by a number of techniques. Tidal flow can be made to drive turbines and such systems are feasible in geographically favourable locations, where the tidal variations are large. If a barrage is constructed e.g. across a river estuary, both the incoming and the outgoing tide can be made use of.

Numerous ingenious mechanical solutions have been proposed to make use of **wave energy**. No doubt that the energy available in waves is huge, but none of these systems is a clear winner yet and very few large-scale installations are in operation.

**Ocean-thermal energy** (OTE) represents a completely different approach. It makes use of the temperature differences between deep water layers (several thousand metres) and the surface layers.

**Table 4.8** Technologies and purposes of solar energy utilisation



The grade of such energy is not very large, but the quantities are huge. Attempts are made to drive various heat engines with this temperature difference.

**Geothermal energy** is the heat of the interior of the Earth. It can be made use of in several ways. Surface utilisation is possible at hot springs or geysers. Notable examples are Rotoroa in New Zealand and Yellowstone in Wyoming, USA. The world's 'most efficient' geothermal system is said to be in Indonesia at Darajat (near the Mt Kendang volcano, in Central Java), producing 81 MW of electricity. A second similar unit is under construction.

In Australia, the heat of deep layers is recovered through bore-holes delivering hot water or by the 'hot-dry rock' (HDR) technology: pumping water down a bore-hole and recovering hot

**Table 4.9** Growth of renewable electricity production

	2000 (in %)	2030 (in %)	
		Extrapolation	With new initiatives
USA and Canada	2	7	11.5
Europe	3	11	25
Japan, Australia and New Zealand	2	5	7.5

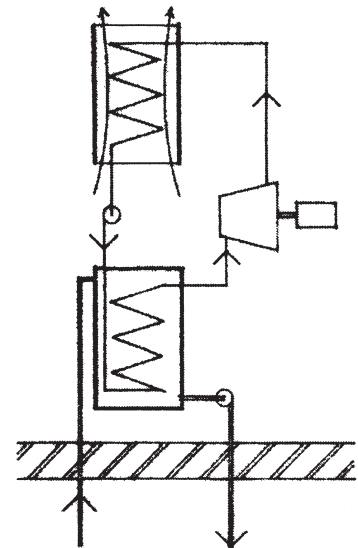
water at quite high temperatures (Fig. 4.26). A 13 MW unit is in operation in the Cooper basin and a 100 MW plant is in preparation. Here at a depth of 3.5 km, solid granite is found at over 250°C temperature. Each of these methods may produce steam to drive turbines, or below boiling point temperatures to drive some form of heat engines, such as 'screw-expanders'.

Low-grade geothermal energy can also be made use of. Temperature of the earth at a depth of 2–3 m is practically constant all-year-round, at about the annual mean air temperature of the location (or slightly warmer). A pipe coil buried at this depth can produce warm water at about this temperature. A similar method saves earth-works by drilling a large number of bore-holes and places a U-pipe in each, to serve the same purpose of acting as a heat source. A heat pump (see Section 1.6.1.1 and Fig. 1.89) can step-up the temperature to a level useful for space heating (at least 30°C). This system is sometimes referred to as an 'active earth-coupled system', or an 'earth-source heat pump' system. Some versions of such installations can also serve as a heat sink, when the heat pump is used in reverse, as a cooling machine for air conditioning.

Over the last 30 years, renewable (mainly solar and wind) electricity generation experienced very high growth rates, albeit from a very low base in 1971 (it was practically nil in 1970). This is summarised in Table 4.9.

#### 4.1.5 Energy storage

This is a major issue with most renewable energy systems, because of the mismatch in the timing of supply availability and the demand. The storage requirements may be short term (e.g. the 24-h cycle) or long term (inter-seasonal). Much work has been devoted to the latter, especially in cold winter climates (e.g. Scandinavia) to store heat collected in the summer to be available in the winter. Such storage must be inexpensive. Underground heat storage in either man-made containers or in natural formations, even in the aquifer, seems to be the most promising.



**Fig. 4.26**  
Principles of a HDR plant.

Short-term storage of low-temperature heat is well developed in storage type hot water systems or block-(unit-) heaters for space heating. Electricity produced by PV or wind generators can be stored in rechargeable batteries, but these are expensive and their useful life is limited (maximum 10 years). Much research effort is devoted to alternative battery systems, but the (improved) lead-acid batteries are still the most reliable. If the generators (PV or aerogenerators) are connected to the grid, the grid itself will take on the role of energy storage.

Energy can be stored by pumping water up to an elevated reservoir, to be used to drive a turbine when needed. Producing compressed air is an alternative, which can drive a turbine or a reciprocating engine as recovery of energy. Kinetic energy storage is provided by large flywheels, accelerated as an input and driving a generator as recovery.

**Reversible chemical reactions** are some of the most promising technologies for the long-term storage of high grade energy. Electricity (DC) may be used to split water into H and O. That hydrogen can be stored or piped to where needed and it can be used in internal combustion engines or in fuel cells to produce electricity. The waste product is only water vapour. Ammonia (NH<sub>3</sub>) is another candidate. With high temperature input, it can be split into nitrogen and hydrogen (thermal dissociation) and the two gases are separately stored and may be made at will to re-combine (in the presence of some catalyst), which is a highly exothermic process. A number of other reversible chemical and electro-chemical reactions have been or are being examined, tested and developed.

Low-grade heat can be stored in the building fabric, often without any extra cost, in elements which are provided for other purposes, such as a concrete floor slab or various masonry walls. It is up to the architect or designer to realise this potential as and when needed.

## 4.2 Energy use

### 4.2.1 Energy use in general

According to the UN Statistical Yearbook (1999 edition), the energy consumption of the world in the six major forms of supply was (and is estimated to will be) as shown in Table. 4.10 (converted from Mtoe into kWh)

The terms *primary* and *secondary* are often used in relation to energy. Coal, oil and natural gas are primary sources. Any of these can be used to generate electricity, which is a secondary form of energy. It is usual to consider that one unit of electricity

**Table 4.10** Energy consumption of the world (in  $10^{12}$  kWh)

	1973	2000	2010	2020
Coal	17.49	27.22	32.73	38.90
Oil	33.49	43.04	53.21	63.68
Gas	11.39	24.43	31.58	41.14
Nuclear	0.62	7.86	8.07	7.23
Hydro	1.29	2.63	3.32	3.96
Renewables	7.87	13.33	15.30	17.21
Total	72.14	118.51	144.21	172.12

**Table 4.11** Energy use in some countries by main categories (as % of total)

	Buildings	Transport	Industry
<i>UN Statistical Yearbook 1992</i>			
Australia	23	29	48
France	37	21	42
Canada	37	24	39
USA	39	27	34
Germany	41	17	42
UK	43	21	36
<i>IEA World Energy Stats. 2002</i>			
World, 1973	39.8 <sup>#</sup>	22.9	37.3
World, 2000	42.4 <sup>#</sup>	25.9	31.7

<sup>#</sup> Includes the small quantities of the 'other sectors' category.

(secondary energy) is equivalent to three units of primary energy. If coal gasification is the source of gas supply, this will also be considered as secondary energy. In gas, and particularly electricity systems, it should be noted where the quantity is measured, at the generating plant or at the final point-of-use.

If, at the national scale, the main energy use categories are taken as industry, transport and buildings, in terms of primary energy, the values shown in Table 4.11 are obtained. It is clear that climate and geography are major influences. In Australia, the climate is mild, so building energy use is relatively less, but there are large distances between cities and towns, so much energy is used for transportation. In the UK much of the building stock is old and thermally inadequate, hence the large use of energy is in buildings, but the country is relatively small, compared to the population, so travel distances are not very large. Furthermore, in the UK, same as in Germany and France, railways take much of the transport requirements, and these are much more energy-efficient than road transport.

#### 4.2.2 Energy use in buildings

Energy can be supplied to buildings in the form of solid fuels (coal, coke, but also firewood), liquid fuels (kerosene, paraffin heating oil), gas or electricity.

In Australia (according to 1999 data) over half of all *electricity* generated is used in buildings (27.6% in residential and 23.1% in commercial buildings), industry is the second largest user (46.4%) with very little used in agriculture (1.6%) and in transport (1.4%).

**Gas** was the main source of energy for lighting in the nineteenth century, but for this purpose electricity is used almost exclusively in all industrialised countries. Piped 'town gas' (or coal gas) supply for lighting and cooking (to a lesser extent for heating) was available in most sizeable towns. In many places, as natural gas supplies became available, the old appliances (burners) had to be converted as this has a much higher calorific value: 33.5–44.7 MJ/m<sup>3</sup> (normally 37–39 MJ/m<sup>3</sup>) as compared with town gas: 14–20 MJ/m<sup>3</sup>. The price of gas was reduced and its use for space heating increased from the 1960s onwards. With the ready availability of piped natural gas, large-scale boilers are used with gas burners and CHP installations (e.g. gas turbine-generators with district heating) are gaining ground.

**Liquid fuel** is still used in small portable appliances for heating and cooking, but also with piped supply. Often, in a housing development a central storage tank is installed (usually underground) which will be kept filled by an oil company. From this a piped supply is provided to each house or apartment, where it is metered and paid for by the occupants as any other public service. In large buildings (or complexes, such as hospitals) there may be a central oil-fired boiler which supplies hot water for direct use or for space heating as well as steam e.g. for sterilisers. There will have to be provisions for oil storage. This may provide an opportunity for cogeneration, CHP installations (see Section 4.1.3.1).

**Solid fuel** was practically the only fuel for space heating in the nineteenth century. It was inefficient, messy, dirty and inconvenient and has been quickly replaced in domestic applications as other fuels became available. In the 1950s, solid fuel had still been used in some large buildings or central boilers of large estates (in district heating schemes) or in industry. It required facilities for handling, storage, moving it from storage to the boiler(-s) as well as for the removal and disposal of combustion products (ashes). The use of coal for transportation (steam locomotives) and for residential purposes has disappeared almost everywhere, but it is still used in industry and it is the main primary source of energy for electricity generation. Here huge quantities of coal are handled, by a system completely mechanised, but the disposal of ashes still remains a problem. Many attempts have been made for its utilisation (e.g. as aggregate for lightweight concrete, or as concrete blocks), but this is a minute portion of the total ash production.

Coal fired power stations are the greatest emitters of CO<sub>2</sub> and other forms of atmospheric pollution. The overall efficiency of coal-to-electricity conversion is about 0.33, so using 1 kWh of electricity means the consumption of 3 kWh of chemical energy (which means some 0.36 kg of best coal), the burning of which will release about 1 kg of CO<sub>2</sub> (slightly more for brown coals and lignite).

Electricity (a secondary energy form) is a very convenient form of energy carrier at the final points of use. It is clean, it is available at the flick of a switch, its conversion efficiency is high for most purposes and the large range of electric appliances available makes its use addictive. We tend to take it for granted and squander it in a prodigal manner.

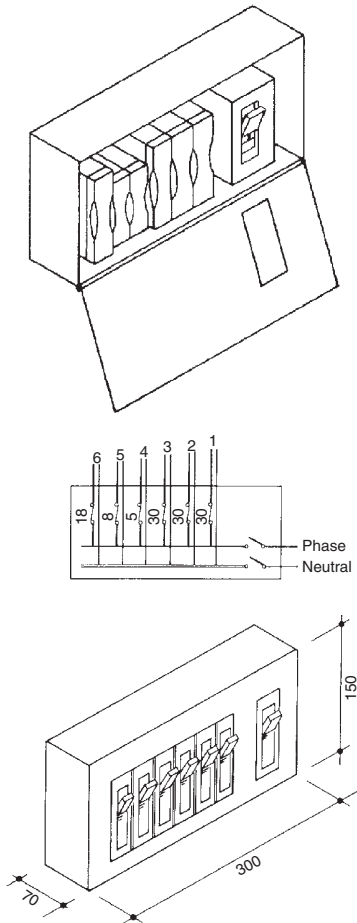
The following sections are to consider electrical and gas supply installations in buildings.

**4.2.2.1 Electrical installations** The local electricity distribution network operates usually at 5 or 11 kV potential. Some large consumers may purchase the supply at this voltage and have their own transformer(s) to reduce it to the standard voltage (240/415 V or 220/360 V or 110/180 V). In residential areas, the supply authority (or company) would have transformers and supply the standard voltage to each customer. Whilst the high voltage distribution uses overhead cables (on poles or pylons) almost everywhere (except in high density CBD areas), the low voltage supply cables are increasingly placed underground.

A house would normally connect to a single phase supply (one of the three phases plus neutral), with a 2-core cable: 'live' (or 'active') and neutral. The *balancing of loads* between the phases is done by the supplier (e.g. 2–3 houses on phase 1, 2–3 others on phase 2, etc.). A block of flats may be connected to a 3-phase supply (a 4-core cable: 3 cores for the three phases plus a smaller one for the neutral) and the balancing is done within the building, between the flats. In a well-balanced system, the neutral will carry very little current, possibly none at all.

In a block of flats in the past, a *sub-main* was taken to each flat or unit and each of these treated as an individual consumer, similar to a house. The trend now is to have all the meters together, e.g. in an electrical switch-room, near the main entrance to the block and run the supply cables separately to each flat, where each would have a *consumer unit* inside the flat, branching out into several circuits, each through a circuit breaker. The common uses ('landlord supply', such as staircase or foyer lighting, lifts, pumps, etc) would be metered separately and paid for by the 'body corporate' (in home units) or the building owner/manager (in rental apartments).

In houses the connection is made to the meter panel (in a meter box accessible from the outside) followed by a consumer unit, which may be inside. Electricity meters measure the voltage and the current, and display the product of the two in kWh. Older meters have a series of rotating clock-hands, 0–9, for each digit



**Fig. 4.27**  
A fuse-board consumer unit and one with circuit breakers.

of the cumulative consumption (very confusing, as some turn clockwise, some anticlockwise, as interlocking gears consecutively divide the rotation by 10). More modern ones have up to 6 disks with numbers on the outside, such as the odometer in cars or combination locks on briefcases, but the latest development is the use of a digital (liquid crystal) display.

In the past, the consumer unit included a series of fuses (rewirable or cartridge type), which would melt (burn out) in case the current exceeded a set limit. Nowadays automatic circuit breakers are used almost exclusively (Fig. 4.27). There is usually one main circuit breaker for the whole supply, then the wiring splits into several circuits, say two lighting and two power-point circuits, each with its own circuit breaker. The stove and the H/W system would have their own separate circuits. Circuit breakers are labelled according to the current they permit before cutting out, such as 5, 8, 15, 20 or 30 A.

Whilst circuit breakers protect the installation against overload (which could cause fire), earthing (or 'grounding' in North America) is used as a safety device to protect the user (shock protection). If the insulation is faulty and the conductor becomes exposed or the metal body of the appliance becomes 'live' and touched by the user, a current will flow through the route of least resistance. The earth wire, connected to metal parts is usually a multi-strand copper conductor, uninsulated, leading to an electrode buried in the ground. This has (we hope) a lesser resistance than the human body, so it takes the bulk of the current, unless the human body is well 'earthed', e.g. bare feet on a wet floor. In this case, the 240 V supply may produce a lethal current through the body. *Earth leakage circuit breakers* are increasingly used, which would be tripped as soon as there is any current going through the earth wire or if the current in the active wire differs from the neutral.

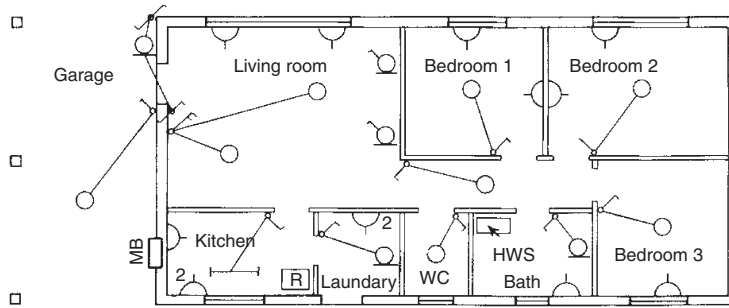
Wiring within a house (or apartment) is usually in double-insulated 3-core PVC cables. The live or active conductor and the neutral are insulated separately and with a bare copper wire for earthing added, the whole is covered by a PVC sheathing. These are often referred to as thermoplastic sheathed (TPS) cables. In exposed flexible cables, the earth wire is also insulated. The colour of the insulated cores is now standardised, but some old cables of different colour are still in use, as shown in Table 4.12.

Whilst these cables can run freely in a framed/sheeted wall or floor and can be embedded in a concrete slab, it is better practice to

**Table 4.12** Standard colours of electrical cables (insulated cores)

Conductor	Standard colour	Old colour
Phase (line, active, live)	Brown	Red
Neutral	Blue	Black
Earth (bare or)	Green+yellow stripes	Green





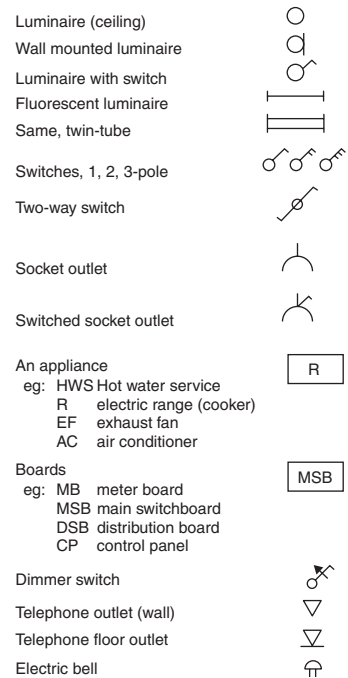
**Fig. 4.28**  
An electrical plan: location of luminaires, switches, etc.

install conduits (with a draw-wire) which would allow re-wiring, should the need arise.

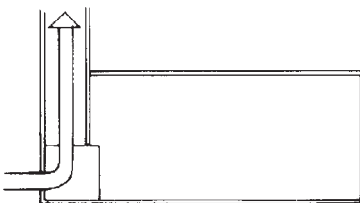
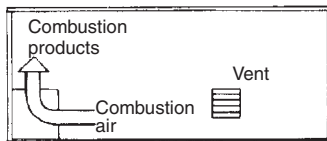
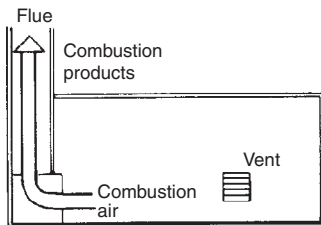
In a larger project an electrical consultant would design the system, in a single house this is usually left to the licensed electrician, but in both cases the architect/designer would set the 'human interface', the location of switches, light points, general purpose outlets (GPOs = power points) and any fixed appliances (e.g. cookers or H/W cylinders). The requirements can be shown on a plan, which is not a circuit diagram (such as Fig. 4.28) using the standard electrical symbols (Fig. 4.29). The architect (in consultation with the client) would normally select the luminaires. It is important to consider the luminous characteristics of these (light distribution, surface luminance thus risk of glare, size of lamps to be used, see Part 2, Section 2.5) and not to select them purely on the basis of 'looks'.

**4.2.2.2 Gas supply installations** Where piped gas supply is not available, gas can be purchased in bottles or cylinder. These must be located outside and a pipe must be carried to the points of use. Bottled gas is often used for cooking and has been used for refrigerators (to drive absorption cooling machines). For larger users, e.g. space heating, gas would be adopted only if piped reticulation is available.

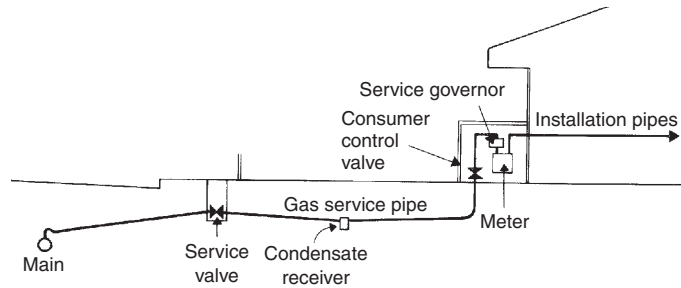
From the gas mains a *service pipe* would connect to the meter (Fig. 4.30) and then the pipe may branch out to e.g. the cooker, the H/W system and the central heating boiler. These boilers are now available in a form which looks like a slightly fat radiator panel and can be installed in any habitable room. A larger H/W system or central heating boiler must have a flue (Fig. 4.31). Boilers may be located next to an external wall and have a *balanced flue* (e.g. Fig. 1.88 which shows a gas fired convector unit). At one stage it was very popular to install gas burners into old open fireplaces, even in the form of artificial 'logs', to imitate a wood fire or glowing artificial embers to look as a coal fire, perhaps including a flickering



**Fig. 4.29**  
Electrical location symbols.



**Fig. 4.31**  
Possible flue arrangements for gas heaters.



**Fig. 4.30**  
A gas service connection.

light. These may well be ‘mood elements’ (for some) but are very inefficient heating devices.

The main concern with gas installations is the risk of leakage. Any small amount of gas leaking out would form an explosive mix with air and could be triggered by a small spark, e.g. from an electric light switch. An argument against the use of gas, citing the many catastrophic gas explosions and fires that regularly occur is usually countered by referring to the equally (if not more) numerous fire disasters caused by electrical faults. The morale of this discussion is that there are risks with any form of energy system, gas or electric or even with open solid fuel fireplaces; the house may be burnt down in a fire started by a candle – all the designer, the supplier and the installer can do is *risk minimisation*. Instructions for use should be supplied with any such system, but the ultimate responsibility should be with the user.

**4.2.2.3 Energy rating of buildings** began in the early 1980s. Several authorities in many countries realised that regulations are not enough to achieve a reduction in energy use. California introduced a building energy code in 1978 and it set a pattern for a two-pronged approach: *prescriptive* or *performance-based* regulations. The former would prescribe in detail many attributes of the proposed building and its components (such as thermal insulation) whilst the latter would set the ‘energy entitlement’ (per unit floor area) for different building types and a number of climate zones. An applicant for a building permit may elect to comply with the prescriptive part or else (s)he must prove, by using an approved computer program (such as those discussed in Section 1.4.4.1) that the proposed building will not exceed its annual energy entitlement.

Such *simulation programs* are also used for producing a star rating for a house (or a plan), which can then be used as a marketing tool. The first such scheme in Australia was released in 1986, as the Five Star Design Rating (FSDR) scheme. Its ‘simulation engine’ was the CSIRO thermal response and energy simulation program

CHEETAH. This was further developed and officially adopted in 1993 as the Nationwide House Energy Rating Scheme (NatHERS). Its use is voluntary, but several authorities require that such a rating be carried out and disclosed if and when the house is put on the market (e.g. based on the *Trade Descriptions Act*). Some authorities stipulate that any design for a new house must be shown to achieve at least a 3-star rating (on a scale of 0 to 5 stars). In one instance recently this has been increased to 4 stars.

An alternative to simulation is a *point-scoring method*, where even the non-professional person can answer a series of (mostly multiple-choice) questions about the house and each answer results in a certain number of points. The number of points awarded for each building attribute had been determined by an extensive simulation-based parametric study. Categories are set in terms of the number of points achieved, for awarding a number of stars. Several states (both in Australia and in the USA) have such methods and the Danish *Positive List Method* is similar.

A survey of the international scene identified some 30 similar rating schemes in operation, most of them in various states of the USA. The EU Council Directive 93/76 required member states to develop and implement *energy certification* of buildings. This may be based on an energy audit of existing buildings or on computer simulation of a planned building.

The French QUALITEL scheme is based on a qualitative assessment but it includes energy use prediction. The Portuguese RCCTE (Regulations on the thermal behaviour of building envelopes) is a combination of prescriptive building regulations and an energy rating. The maximum allowable energy is set and building data can be fed into a spreadsheet, that will predict the expected energy use. If this is below the set limit, a building certificate will be issued, giving a rating on a scale of fair/good/excellent. The implementation of this system is at present voluntary, but it is intended to become compulsory in the future.

In the UK, based on the BREDEM method (see Section 1.4.4.1) the Open University developed the Milton Keynes Energy Cost Index (MKECI) and a modified version of this is the National Home Energy Rating (NHER) system, which is the basis of the computer program *Home Rater*.

Such energy ratings often become the basis of compulsory regulations.

Some building control authorities (especially in South-East Asia) use the overall thermal transfer value (OTTV) concept to prescribe the thermal characteristics of the building envelope. This can be considered as an average U-value for the whole of the building envelope, including solar radiation effects. Its calculation is based on the following equation:

$$\text{OTTV} = \frac{A_w U_w T_{\text{eq}} + A_f U_f D T + A_f S C * S F}{A_t}$$

where

- A = area of each element
- $A_t$  = total envelope area
- U = U-value of each element
- $TD_{eq}$  = equivalent temperature difference
- DT =  $T_0 - T_i$  (averages)
- SC = shading coefficient
- SF = solar factor ( $W/m^2$ )

and the subscripts

- w = walls
- f = fenestration (windows).

The calculation of the  $TD_{eq}$  is quite involved (it makes an allowance for solar input). It is a derivative of the TETD/TA (total equivalent temperature differential) method (ASHRAE, 1972), where TA indicates time-averaging. The method relies heavily on tables presenting empirical (simplified) values and is falling into disrepute. Furthermore, the SF concept is no longer in use (see Section 1.4.1.3).

Most countries now have energy-related building regulations. In the UK, one of three methods can be used to satisfy such regulations:

- (1) the elemental method: each element is to achieve the prescribed U-values and window sizes are limited to 22.5% of the floor area;
- (2) the 'target U-value' method: a weighted average U-value is prescribed and calculations must show that it is achieved; provisions against thermal bridging and infiltration control must be demonstrated;
- (3) the energy rating method, which includes ventilation/infiltration as well as service water heating (SWH).

The U-value requirement is fairly stringent: a maximum of  $0.25 W/m^2 K$  is allowed for roof and  $0.45 W/m^2 K$  for walls.

The New Zealand system is similar, only the terminology is different. The three methods distinguished are Schedule method, Calculation method and Modelling method. The last of these requires the use of a building thermal response and energy use simulation program. The insulation requirements are not as stringent as in the UK: even in the coldest of the three climatic zones distinguished, the prescribed value is R2.5 for roofs and R1.9 for walls, which corresponds to U-values of 0.4 and 0.52, respectively.

The Australian Building Code of Australia (BCA) distinguishes eight climatic zones, from the hot-humid North, to the 'alpine' zones of the cool-temperate Tasmania and the south/east mountainous area (of NSW and Victoria). The stated 'performance requirements' are qualitative only, which can be satisfied by either following the deemed-to-satisfy provisions ('acceptable construction') or by 'alternative solutions' which are shown to be equivalent

to the former, either by a recognised computer program (such as NatHERS mentioned above) or by 'expert opinion'. Generally the requirements are fairly timid. The stated aim is not to achieve 'best practice' but only to eliminate 'worst practice'. Insulation requirements (except for the mountainous areas) are  $R1.9$  ( $U = 0.52$ ) for walls and the (quite respectable)  $R3.7$  ( $U = 0.27$ ) for roofs. An interesting point is that for roofs in the northern zones, downward heat flow is taken as critical, whilst upward heat flow is controlled in the south.

In the USA almost each state differs, but many adopt the Model Energy Code (MEC) as the basis of regulations. The MEC also allows three routes to compliance:

- (1) following the prescriptive package
- (2) the trade-off approach and
- (3) the software approach.

The International Energy Conservation Code (IECC) is referenced at many levels, which regulates the building envelope as well as heating, ventilation and air conditioning (HVAC), service water heating (SWH) and lighting installations. It is called 'international', but it appears to be a USA code. It references ASHRAE and Illuminating Engineering Society (IES) standards and divides America into 38 climate zones.

### 4.2.3 Energy conservation

The term refers to the conservation of conventional, non-renewable energy sources and many would prefer the term *rational use of energy* applied to all forms of energy. Energy use in buildings is determined by four sets of decisions:

- 1 **Setting of environmental standards:** Attempts at conservation do not mean a 'lowering' of standards, but the setting of reasonable standards, e.g. not setting the thermostat at  $25^{\circ}\text{C}$  for winter, when  $22^{\circ}\text{C}$  would be adequate, and not cooling the building to  $22^{\circ}\text{C}$  in the summer, when  $27^{\circ}\text{C}$  may be quite comfortable, i.e. rely on the adaptability model of thermal comfort. Similarly in lighting: an illuminance of 800 lx would require twice as much energy as 400 lx, and the 400 lx may be quite adequate for most office-type tasks.
- 2 **Building form and fabric:** The effect of these has been discussed quite extensively in Part 1.
- 3 **Environmental control installations:** In this area we have to rely on engineering advice to a large extent, but often the architect can influence design decisions and achieve greater efficiencies, avoid the wastage of energy. Examples of this may be the choice

of compact fluorescent lamps rather than incandescent, or making sure that the air conditioning condenser unit is not exposed to solar heat input.

**4 Choice of energy source including renewables:** The decision for such often rests with the client and it may be based on economic considerations. These will be discussed in Section 4.4.3, but the architect should consider the possibilities, examine the feasibility of a chosen technique and advise the client accordingly.

A possible list of energy conservation measures has been suggested at a recent conference:

<i>Building</i>	<i>Installations</i>
Daylighting	Controls of HVAC systems
Shading	Energy-efficient HVAC
Natural ventilation	Economizer cycle
Insulation	Exhaust air heat recovery
Thermal mass	Energy-efficient lamps
Solar air preheating	Reduced duct leakage
Improved windows	Photovoltaics
Air infiltration control	Solar water heating
Passive solar heating	

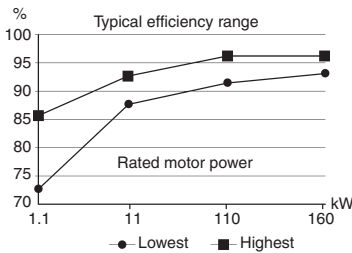
The list is by no means comprehensive, but it includes most of the main measures. A few additional issues are mentioned below, that the architect may keep in mind and advise the client or may remind the consulting engineer.

The efficiency of electric motors varies between quite broad limits, especially for smaller motors (72–96%), as shown in Fig. 4.32. If energy is to be conserved, the use of high efficiency motors should be a requirement. Their initial cost may be slightly higher, but in terms of life cycle cost (LCC) analysis they are quite superior.

In an electricity supply system, it is not only the overall load and consumption that is critical, but also its timing. The generation of peak-time electricity is far more expensive than the supply of base load. As the system must be capable of satisfying the peak demand (even if that occurs only for a short period) there is much generating capacity which lies idle most of the time. It can take up to 12 h to start up a steam turbine generator set, thus there is no point in stopping them during off-peak periods. They are often referred to as *spinning reserve*.

Suppliers are anxious to level out the load, especially by *demand-side management* (DSM). This includes various pricing strategies, such as

- (1) off-peak tariff, much cheaper than normal, for purposes not time-dependent, such as storage-type domestic hot water system or storage-type 'block' heaters or indeed 'ice storage'



**Fig. 4.32**  
The efficiency of electric motors.

systems for air conditioning (here a large volume of water would be frozen overnight, using cheap electricity, and the next day it would provide chilled water for air conditioning, i.e. making use of the latent heat of fusion of ice);

- (2) interruptible supply: the supplier can send out a high frequency signal through the supply cables to trigger a switch in the consumer's meter box, which can cut off (or switch back) non-essential circuits at peak periods;
- (3) two-part tariffs, where the consumer pays a flat rate for all electricity used (energy rate) but also pays according to the peak load reached during the billing period (power rate). In some cases, where such metering and registering of peak power is not available, there may be a charge according to 'total connected load';
- (4) the latest development is digital metering, which allows the use of 'time-of-day' tariffs: higher prices at peak periods, lower prices in the off-peak 'troughs'.

A single consumer may have at least two meters, one for the 'normal' consumption (lighting and power points) and one for a 'special tariff' for off-peak domestic hot water and space heating (block or unit heaters) or for interruptible supply. In office and commercial buildings a large tank of water may be frozen overnight, using cheap off-peak electricity and the following day the melting of this ice (an endothermic process) would provide chilled water for the air conditioning system.

Attempts for levelling out energy use rate at the individual consumer level have been made in the 1960s and 1970s, by the so-called *load shedding* systems. All electric loads in the house would be ranked into an order of priority and grouped into separate circuits. A maximum load would be set and when that were to be reached, the lowest priority load would be 'shed', i.e. that circuit switched off. Such systems are now available in an electronic version, named Intelligent Home Gateway (IHG).

*Supply side management* (SSM) systems include various arrangements to utilise surplus capacity at off-peak times (by large buffer storage systems) and make use of this at peak periods, such as

- (1) pump-back systems, which can be used if the grid has some hydroelectric generation components: the surplus capacity can be used to pump back from a lower level (small) reservoir up to the main reservoir, to be re-used to drive the turbines at peak periods;
- (2) other storage devices, which include batteries, reversible chemical reactions (e.g. ammonia dissociation), compressed air, flywheels and superconducting magnetic energy storage (SMES);
- (3) distributed generation (DG), which means the incorporation into the grid a multitude of small-scale generators, from

**Table 4.13** The relationship of energy use and greenhouse emissions (in %)

End-use	Energy consumption	Greenhouse emissions
Buildings	46	54
Defence establishments	37	40
Transport	15	5
Other	2	1

*Source:* WOGER: Whole Government Energy Report, Canberra 2002.

micro-hydro or wind turbines to building-mounted PV systems. This is often considered as using the grid as storage, which is feasible because of the favourable diversity factors of the many small generators (e.g. wind is usually strongest when there is no solar radiation).

Energy conservation and substitution of renewable energy resources is imperative not only because of the finite availability of oil and coal, but also because of the atmospheric pollution, primarily CO<sub>2</sub> emissions due to their use. The magnitude of greenhouse gas emissions is not directly proportional to energy use, but certainly energy use is responsible for most greenhouse gas emissions. This can be well illustrated by statistics from the Australian Government, shown in Table 4.13, as percentage of all energy use and emissions by government properties and activities.

## 4.3 Water and wastes

### 4.3.1 Water

The human body requires a minimum of 1 L of water per day for its normal functioning. The usual amount of intake is some 2 L/day, in the form of food and drink. The per capita water consumption in a large city can be as much as 2000 L (2 kL or kilo-litre = m<sup>3</sup>). How is the remaining 1998 L used?

The answer is that it is used mostly by industry and commerce, but also for some other purposes (on average in %):

Residential buildings	44
Industry	22
Commerce	18
Health facilities	5
Parks and streets	7
Urban fringe agriculture	4



In residential buildings alone, the per capita use is 500–800 L/day. This domestic consumption approximately divides as (in %):

Ablution and sanitation	36
Cooking, washing up, laundry	23
Household gardens	41

Obviously there are large variations with the type of accommodation unit (house and garden, or high-rise apartment block) and with the climate. In a dry climate more is used for gardening. A domestic swimming pool can lose 5–10 mm of water per day by evaporation, depending on the weather (more on a dry, hot and windy day) which on a 50 m<sup>2</sup> pool may add up to 250–500 L/day.

The commercial use is made up of components such as

Offices	120 L/pers.day
Hotels	1500 L/room.day
Restaurants	10 L/meal served
Laundry	40 L/kg of washing

All our fresh water is the product of solar energy. It causes evaporation, largely from ocean surfaces, and starts the hydrological cycle. Vapour laden air and clouds are carried by winds (which themselves are produced by differential solar heating). Precipitation (rain, snow) will also occur over land areas. Some of this may run off and form streams and rivers, some may be retained by the soil, some may percolate into porous subsoil strata. We may tap any of these sources, but all this water comes from precipitation.

Dry land areas of earth receive (on average) about 1000 mm rainfall per year, but this may vary between some 200 mm (e.g. in North Africa) and 2600 mm (in western parts of India and Central America). It also varies from year-to-year. An annual variation of  $\pm 20\%$  is considered as highly reliable. Some desert areas may receive rain once in 10 years.

Gaining water can take many forms, from collecting roof water in tanks to large dams collecting run-off from their catchment area. Near-surface ground water may be obtained through shallow wells. Deeper water-bearing strata may be tapped by bore-holes. Natural springs may be made use of. Rivers can provide water by surface pumping, by wells near the flow-bed or by construction of dams to form water reservoirs. The problems are both the quantity and the quality of such supply.

River valley authorities or other water resources management bodies may exercise strict control both over the allocation and use of the available water and over the possible sources of water pollution. In some instances, the whole catchment area of a water reservoir is controlled. It is a continuing struggle for both preserving the quality and to justly divide the water available among

potential users. Water used for agricultural irrigation is a huge quantity and the right to use it is often disputed.

Potable water (for human consumption) must satisfy the following criteria:

- It must be clear, free of any suspended clay or silt. Many natural sources provide *turbid* water. Turbidity can be controlled by filtering.
- It must be without taste or odour. Taste and smell are caused by foreign matter, which should not be present in the water.
- It must not contain chemicals in dangerous or harmful quantities. Maximum permissible levels (in ppm i.e. parts per million) are established for many possible substances. Frequent analysis should ensure that these limits are not exceeded.
- It must be free of bacteria and other micro-organisms. Minute quantities of some are tolerable, but these should be checked by frequent counts. Most common one is the *bacillus coli*, which causes *enterocolitis*. A count of 100/mL is the acceptable limit.

Waterworks are usually operated by local authorities or water boards, being consortia of several such authorities. These include pumping, filtering and water treatment facilities. Sand filters can remove solid particles down to about 0.1 mm size. As most bacteria adhere to the surface of such particles, these will also be removed. Bacteria on their own are about 1  $\mu\text{m}$  in size, and cannot be removed by filtering. If such bacteria are found after filtering, the water must be disinfected, most often by adding chlorine of 1 ppm ( $1\text{g}/\text{m}^3$ ). At the draw-off points, chlorine should not exceed 0.2 ppm, as this could add an undesirable taste. Ozone treatment is equally effective, it is without taste or harmful effects, but it is expensive.

Long-distance pipelines are designed for continuous flow from the source to local service reservoirs. The function of these is to even out the fluctuations of demand. In some countries (e.g. in the UK) many authorities 'pass the buck' to even out the flow in the local pipework: any residential unit is allowed only a 13 mm pipe connection and one tap on this service in the kitchen, all other outlets must be served from a high level storage tank or cistern to serve as a buffer. At peak times these may be almost emptied and will be refilled only slowly, through a float-valve.

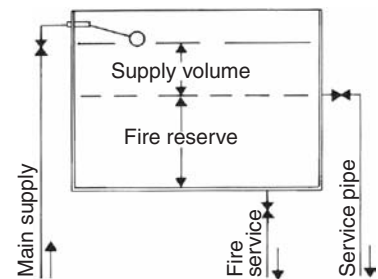
**4.3.1.1 Water supply** in buildings must be available for the following purposes:

- domestic: drinking, cooking, toilet flushing, as well as both hot and cold supply for baths, showers, basins, kitchen washing up and laundering
- fire fighting: automatic sprinklers and hydrants (for use by the fire brigade) and hose reels (for occupants' use),

- environmental plant: air washing and humidification, evaporative cooling and heat transport (incl. cooling towers)
- external: garden hoses and sprinklers, car washing, etc.
- manufacturing: process cooling and industrial process water for a multitude of purposes.

The design and installation of the water system is often left to the licensed plumber, to serve all fittings indicated by the architectural plans. In larger buildings, a consulting engineer may do this work. It is however the architect's task to show what fittings are to be installed and where. A few small points are worth remembering:

- 1 Grouping all the 'wet' areas would reduce both the water and the drainage pipework necessary.
- 2 It is both wasteful and irritating when opening a hot tap one has to wait for the hot water to arrive after discharging the cold water content of the 'dead leg' pipe. This is wasting much water, but also energy. After a short use of the hot water, the dead leg pipe is full of hot water and will lose its heat in a short time, even if the pipe is insulated. In a residential unit, it is the kitchen where a small amount of hot water is used quite frequently. It is therefore advisable to have the H/W system near the kitchen.
- 3 In a hotel or hostel-type building, a whole series of draw-off points may be served by a hot water loop. The hot water is slowly circulating (a small pump may be used) and it is available as soon as a tap is opened. The piping in this case should have a good insulation. Even then some heat may be lost, but much water would be saved. This has been mentioned in Section 1.6.2 (hot water supply) and shown diagrammatically in Fig. 1.100.
- 4 In buildings of more than 1 or 2 stories, it is useful to have a tank full of 'fire reserve' water at the highest level. In many places this is a statutory requirement. Where service water storage is also a requirement, the two can be combined by using the piping arrangement shown in Fig. 4.33.
- 5 Up to the middle of the twentieth century, the piping was often installed on the outside of the building (often such piping was an afterthought, or a later addition in 'modernisation'). Even in London's relatively mild winters, this often led to the freezing of water in the pipe and – as water expands as it freezes – this often caused cracks in the pipes and consequent leakages. Today all pipes are located internally, but it is useful not to 'bury' pipes in the building fabric, but place them into service ducts or make them accessible by other means (e.g. using removable cover plates). Plumbing repairs may cause consequential damage much more costly than the plumbing repair itself. Even the best pipework is unlikely to be trouble-free for more than some 30 years, whilst even the cheap and flimsy buildings would have a life expectancy of at least three times that.



**Fig. 4.33**  
Combined supply header and fire reserve tank.

### 4.3.2 Wastes

Our civilisation, particularly our towns and cities produce a huge amount of waste. This includes solid, liquid and gaseous wastes and the following is to examine these in turn.

**4.3.2.1 Gaseous wastes** today mostly consist of motor vehicle emissions and the discharge of power stations and heavy industry. In the past it consisted mostly of visible smoke (mainly fly ash, soot) and (with internal combustion engines) some metallic particles: lead, mercury, cadmium. The thousands of smoking chimneys of residential districts, the chimney stacks of industries and railway steam engines were the prime causes of air pollution, especially of the London fogs and the sooty, grimy blackness of industrial cities.

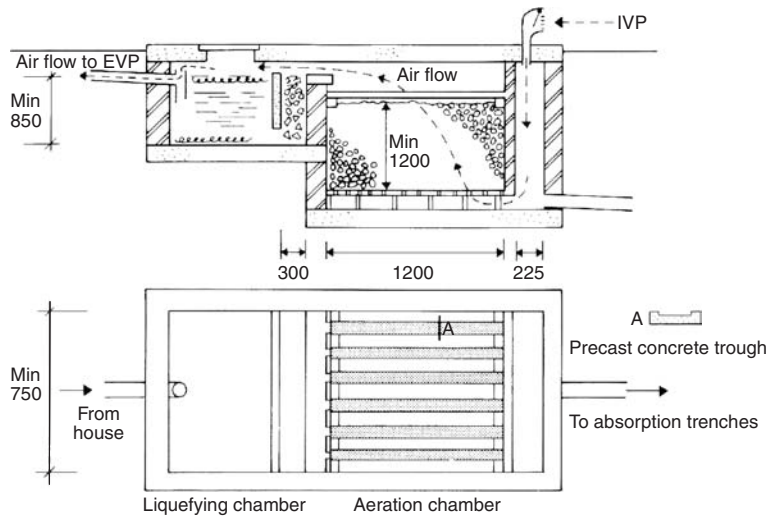
The UK 'Clean Air Act' of 1956, the 1963 Act of the same name in the USA (and similar legislation in many other countries) radically changed the situation. Fuels were changed, new technologies were introduced, controlling agencies were established by governments and emissions were drastically reduced. Catalytic after-burners reduced motor vehicle emissions and power stations started building super-tall chimney stacks (up to 300 m). The latter helped the local atmosphere, but produced long-distance effects, such as the sulphuric rains in Scandinavia caused by the tall chimney emissions of North of England power stations.

It is interesting to note how our understanding and our reactions change. In the 1950s all blocks of flats in Sydney had to have an incinerator (!), to reduce domestic solid wastes. Now these are banned and the air is much cleaner. Today buildings emit very little (if any) gaseous wastes, but emissions are only shifted: electricity consumption in buildings is responsible for huge amounts of CO<sub>2</sub>, NO<sub>x</sub> (sodium oxides) and SO<sub>x</sub> (sulphurous oxides) emissions.

Much can be done to reduce such emissions. The use of various catalysts (platinum, aluminium) over the last decade reduced gas turbine emissions of sulphur, nitrogen and carbon monoxide from 25 to 2 ppm.

**4.3.2.2 Liquid wastes** from buildings are largely the product of our sanitary arrangements. Since the nineteenth century, our disposal systems, both sanitary fittings and the supporting pipework have improved tremendously. Up to the 1950s the *two-pipe system* was generally used, separating the waste water pipes (the discharge of baths, showers, basins, kitchen sinks and laundry tubs) and the 'soil' pipes (servicing WC pans, urinals and slop hoppers). Subsequently, the *one pipe system* took over and the installations were much simplified.

Today, at least at the domestic scale, it is taken as desirable (and beginning to be adopted) to separate the 'grey water', what was

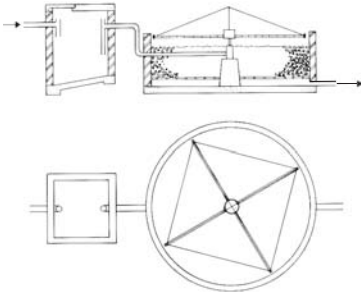


**Fig. 4.34**  
A built in situ domestic septic tank.

earlier referred to as 'waste water' and to make use of it, for flushing the toilet, watering the garden, or hosing down the driveway. This would obviously need a storage tank and separate pipework. The 'black water', the effluent discharged by soil fittings, must be connected to the public sewerage system to be treated at 'sewage farms'. In less densely built-up areas, or for isolated houses, this effluent may be treated within the site, in septic tanks.

These domestic scale septic tanks and the public sewage treatment plants are based on the same principles. Fig. 4.34 shows the section and plan of a domestic septic tank. The first chamber is just a holding tank, sometimes referred to as the liquefying chamber, where *anaerobic bacteria* decompose organic matter (consuming some 30% of organic solids), which constitutes the *primary treatment*. Methane ( $\text{CH}_4$ ) and  $\text{CO}_2$  are produced and must be vented to the atmosphere. A slightly modified set-up may allow the methane to be collected and used as a fuel (see Section 4.1.4.2, under biomass conversion). In some large-scale sewage treatment plants, the methane collected is used to generate electricity in the MW order. One plant in Sydney operates a methane-based CHP system, producing 3 MW electricity and 3 MW of thermal energy.

*Secondary treatment* is provided in the aeration chamber which (in this case) is a series of trays set exactly horizontal, allowing the effluent to be sprinkled over a gravel (or crushed rock) bed, where on the surface of gravel particles *aerobic bacteria* breed. These will consume a further 60% of organic matter. Good ventilation of this chamber must be ensured. An alternative to this chamber (for larger systems) is an open, circular gravel bed with a slowly



**Fig. 4.35**  
A rotary aeration facility.

rotating spraying system (Fig. 4.35) to distribute the effluent from the anaerobic tank.

The effluent at this stage is rich in phosphates and nitrates: a good fertiliser. It may be used for watering, but it must not be allowed to enter natural waterways, as it may cause algae blooming. These have a large biochemical oxygen demand (BOD), deoxygenate the water, which may no longer be able to support aquatic life and may become abiotic.

A *tertiary treatment* of sewage (a more complicated process) may remove phosphates and nitrates and produce a marketable fertiliser. The solid residue (sludge) of the primary and secondary treatment may be dried and incinerated. The ashes left may be used for land fill ('concentration and confinement') or loaded on barges and dumped at sea ('dilution and dispersal').

**4.3.2.3 Solid wastes** (refuse or trash), normally collected by garbage trucks (using a variety of mechanised systems). The average waste produced is about 1 kg/pers.day in the UK, 1.5 kg/pers.day in Australia and up to 2.5 kg/pers.day in the USA. The collection, handling and disposal of this is quite a problem. Garbage tips have been created in disused excavations, quarries or clay pits, filled, compacted and covered with earth. In flat areas quite large garbage hills have been created, covered with earth and landscaped. However, we are running out of space for the creation of such garbage dumps.

Large-scale incinerator plants have been built, some of which can be used to generate steam and drive an electricity generation system. Local authorities are quite desperate in trying to reduce the bulk of such wastes. Various levels of recycling arrangements have been introduced. At the simplest level, residents are asked to separate the recyclable and non-recyclable wastes, in other cases paper, glass, metals and plastics are collected separately, and directed to various recycling plants. The paper recycling industries are now quite significant, but only a few plants are commercially successful. Most require some public assistance, at least to get started.

The possibility of collecting methane gas generated in garbage dumps has been mentioned in Section 4.1.4.2 (biomass conversion). The disposal of toxic industrial waste is quite a problem, but beyond the scope of this work.

## 4.4 Sustainability issues

Environmental degradation was already the main concern of the Stockholm UN conference in 1972. In the following year, the OPEC oil embargo brought home the realisation of the finite nature

of our fossil fuel supplies. Already in 1973, the RIBA (the then president Alex Gordon) initiated the long life, lose fit, low energy (LL/LF/LE) movement. The philosophical basis of this was that it would be ecologically beneficial to erect buildings which last, which are designed in a way to remain adaptable for changed uses and which use little energy in their operation. The term 'sustainability' did not exist then, but it was a program for sustainable architecture.

The Brundtland report (1987) introduced the term and gave the definition as

Sustainable development is development that meets the needs of the present without compromising the ability of future generations to meet their own needs.

The latter point has been labelled as 'inter-generational equity'.

In 1987, the Montreal protocol agreed on the phasing out of organo-fluorides, which are affecting the ozone layer and as a consequence admit more UV irradiation.

The 'Earth Summit' (1992) United Nations Conference on Environment and Development (UNCED) considered environmental degradation together with resource depletion and broadened the discourse in Agenda 21 and with the 'Rio Declaration' laid down the principles of sustainable development.

Equity for all humanity is one of the aims of Agenda 21, but inter-generational equity is perhaps even more important.

Architecture joined the movement by the *Declaration of Interdependence for a sustainable future* at the Chicago Congress of the IUA in 1993 (see Appendix 1). Many national bodies and institutions of architecture adopted this declaration and produced energy and environmental policies. As an example, Appendix 2 presents the Environment Policy of the Royal Australian Institute of Architects (RAIA). Such declarations and policy statements are fine words only, but even if not immediately effective, they have a significance: they imply a commitment which individuals must recognise at the risk of being 'politically incorrect', they must pay at least lip-service to these and with frequent repetitions they do become the accepted norm. Even if an individual fails to act accordingly, at least he/she will have a guilty conscience about it.

#### 4.4.1 What can architects do?

The main practical question is how these noble ideas can be translated into actions at the level of everyday reality. Design may be constrained by clients and regulatory authorities. However, architects work at many levels and may influence the development process. Architects may be employed by client organisations. As facility managers may influence the client on building needs. They

may be involved in site selection and feasibility studies. They may assist in formulating the brief, which may involve a series of background studies concerning organisational and social aspects, as well as ergonomics and environmental requirements.

The process from briefing to design is an iterative one. The architect may ask for clarification of the brief and may influence the client by expert advice. The conceptual design is often separated from the detailed design of the fabric and contract documentation. It may even be done by a different architect or firm of architects. Supervision of the building work and contract management is a distinctly separate task. Even if the whole process is carried out by one firm, different individuals may specialise on certain tasks.

Many building companies employ their own architects. Many architects specialise in interior design for shops, for shop front design or office interior 'fit-out'. Some become writers, critics, journalists, educators or theoreticians. Architects may work for local authorities and may have an influence on town planning and urban design, may have various regulatory tasks. They may have a role in the building approval process, which is not just a yes/no task, it may involve negotiations with the designer and developer to modify the proposal in the interest of the 'public good'.

At each of these levels environmental issues are involved and must be considered. Early decisions may have unforeseen consequences: they may preclude later, environmentally sound decisions. Every action may have environmental consequences. Environmental and sustainability issues are survival issues, thus must have top priority and a decisive role.

Amongst the many roles the architect can play, the one central task is the design of buildings. Design dominates the architectural ethos. However, design is much more than just the looks of the product. Sustainability, how the building works, how it uses resources can be considered under four headings: *site, energy, materials and wastes*.

**4.4.1.1 Site.** Land is precious. All building activity disturbs the land, the site. Such disturbance ought to be minimised. Undisturbed land, supporting an intact ecology is particularly valuable. If possible, its use should be avoided. This could be a step in preserving biodiversity. The use of already disturbed, possibly derelict land would be preferable. Rehabilitation of disturbed or neglected land is desirable.

Buildings should fit their environment: if possible, large-scale earth-works should be avoided. If earth-works are unavoidable, the top soil, which is a valuable living system, should be preserved, stored and used in landscaping. All possible steps should be taken to prevent soil erosion, to promote land and soil conservation and, wherever possible, improvement.



**4.4.1.2 Energy** is used in buildings at two levels:

*Operational energy* (O), annually used for heating, cooling, ventilation, lighting and servicing the building. This has been discussed in Section 4.1 and, indeed, throughout this book.

*Capital energy* (C) or energy embodied in the materials and building processes. It is interesting to note that in the early 1970s, when building energy analysis was in its infancy, the C/O ratio was found to be around 5, i.e. the building would use as much energy in 5 years as was necessary to produce its materials and construct it. For a very poorly constructed building, the ratio was as little as 2.5 (i.e. 2.5 years). Recent analyses show ratios of 30 to 40. One study even concluded that it was 50.

The reason for this is two-fold: buildings have been improved and such improvements would have increased the capital energy (embodied energy), e.g. thermal insulation, but also many plastics and metal products. At the same time, better buildings resulted in a reduced operational energy consumption. In the 1970s, efforts were focused on reducing this operational energy use. Now the major concern shifted and attempts are made to reduce the embodied energy.

The embodied energy, or to be precise: the 'process energy requirement' (PER) of some materials is shown in Table 4.14.

There are large differences in published data regarding the embodied energy of materials, partly due to local differences in the industrial processes, but partly also due to the different calculation methods. In broad terms, two methods can be distinguished:

The **analytical method** follows the processes from gaining the raw material through various stages of manufacture and

**Table 4.14** The process energy requirement of some building materials in kWh/kg

Air dried sawn hardwood	0.14	Wood particle board	2.22
Stabilised earth	0.19	Plywood	2.89
Concrete blocks	0.39	Glued-laminated timber	3.05
Precast tilt-up concrete	0.52	Medium density fibreboard	3.14
In situ cast concrete	0.47	Glass	3.53
Precast steam-cured concrete	0.55	Hardboard	6.69
Kiln-dried sawn hardwood	0.56	Mild steel	9.44
Clay bricks	0.69	Galvanised mild steel	10.55
Gypsum plaster	0.80	Acrylic paint	17.08
Kiln-dried softwood	0.94	Zinc	14.17
Autoclaved aerated concrete	1.00	PVC	22.22
Plasterboard	1.22	Plastics in general	25.00
Cement	5.60	Copper	27.78
Fibrous cement	2.11	Synthetic rubber	30.56
Granite slabs	1.64	Aluminium	47.22

(after Lawson, 1996)

**Table 4.15** Embodied energy of some building materials in kWh/kg

<i>Low</i> <1 kWh/kg	Sand, gravel	0.01
	Wood	0.1
	Concrete	0.2
	Sand-lime brickwork	0.4
	Lightweight concrete	0.5
<i>Medium</i> 1–10 kWh/kg	Plasterboard	1.0
	Brickwork	1.2
	Lime	1.5
	Cement	2.2
	Mineral wool	3.9
	Glass	6.0
	Porcelain	6.1
<i>High</i> > 10 kWh/kg	Plastics	10
	Steel	10
	Lead	14
	Zinc	15
	Copper	16
	Aluminium	56

transportation to the installation in the final product, the building, and adds up all the energy used;

The **statistical method** examines the particular industry of a country, a state, or a region, attempts to establish the total energy use by that industry as well as its total output; dividing the latter by the former gives the embodied energy per unit mass (or other production unit).

The best data are likely to be the integration of results of the two methods.

Table 4.15 is based on a number of different sources and groups building materials into three broad categories: low, medium and high energy materials. The comparison between Tables 4.14 and 4.15 is a good illustration of this point. Note also that the numbers in Table 4.14 imply an accuracy which is unlikely to exist.

**4.4.1.3 Materials** selection must be influenced by this embodied energy, but also by a number of other issues affecting sustainability of their use. A typical evaluation system, building materials assessment system (BMAS) uses 14 criteria, as shown in Table 4.16. In using such a table for evaluating a material, a score of 0–5 is awarded against each criterion, rating its environmental impact. Thus, 0 is no impact, 5 is much impact. ‘Help’ tables are available to assist such scoring. Then each score is squared (to get a better resolution) and the weighting factors (shown in Table 4.16) are applied to each score.

The sum of the 14 squared and weighted scores is the ‘ecological factor’ (EF) of the material. This is not claimed to be more

**Table 4.16** Building Materials Assessment System (BMAS)

Group	Criteria	Weighting	Grp.
Manufacture	1 Damage to the environment in the extraction of raw material	3	
	2 Extent of damage relative to the amount of material produced	2	
	3 Abundance of source or renewability of material	4	
	4 Recycled content	3	12
	5 solid and liquid wastes in manufacture and production	3	
	6 Air pollution in manufacture and production	4	
	7 Embodied energy (energy used for its production)	5	12
Construction	8 Energy used for transportation to the site	3	
	9 Energy used on site for assembly and erection	1	
In use	10 On site waste, including packaging	2	6
	11 Maintenance required during life cycle	3	
Demolition	12 Environmental effects during life cycle (e.g. toxic emissions)	3	6
	13 Energy use in and effects of demolition at end of life cycle	2	
	14 Recyclability of demolished material	4	6

than a qualitative guidance figure. The scoring can be biased and the weighting factors have been established by seeking an 'expert consensus'. However, this is the most comprehensive system for judging building materials from the sustainability viewpoint.

It is worth noting that the criteria are strongly interconnected, e.g. although timber has low embodied energy, it will have a low eco-rating only if it comes from renewable resources, i.e. if it is plantation timber. If it comes from 'original growth' forests, produced by a clean-felling method, possibly causing soil erosion, its EF will be quite high.

A simpler method developed by Lawson (1996) gives an 'environmental rating' of various building products on a straightforward 5-point scale:

1: poor, 2: fair, 3: good, 4: very good and 5: excellent

He applies this rating to seven categories or attributes, as shown in Table 4.17.

**4.4.1.4 Wastes** have been considered in some detail in Section 4.3.2 above and it is apparent from that discussion that architects can have a strong influence on how wastes are disposed.

**Table 4.17** Environmental rating of some materials (on a 5-point scale)

	Raw material availability	Environmental impact	Embodied energy	Product life span	Freedom from maintenance	Product re-use potential	Material recyclability
Plantation-grown sawn softwood	4	4	4	3	2	2	1
Hardwood from native forests	2	2	5	4	3	4	1
Wood fibre hardboard	4	4	2	3	2	1	3
Medium density fibreboard (MDF)	5	4	3	3	3	3	2
Particleboard (chipboard)	5	4	3	3	3	1	4
Plywood	4	4	3	4	3	3	1
Glued laminated timber	4	4	4	4	3	4	2
Plastics (synthetic polymers)	3	2	3	4	4	1	3
Stabilised earth (cement or bitumen)	4	5	4	3	3	1	5
Building stone (sawn)	3	2	3	4	4	4	3
Clay bricks	4	3	4	5	5	2	3
Cement-concrete products	3	3	4	5	5	1	3
Fibrous cement (pine fibre)	4	4	3	5	5	1	1
Glass	3	3	3	5	4	3	4
Steel	4	3	3	4	3	3	5
Aluminium	4	1	1	5	4	2	5
Copper	2	1	2	5	5	1	5
Lead and zinc	2	1	2	5	5	1	5

*Note:* No attempt should be made to add up these numbers. The rating is purely qualitative and in the original no numbering is used. Here it is simply a convenience or short-hand to identify the qualitative rating.

In addition, attempts should be made to retain as much of any stormwater on the site as possible: collection and storage of roof water, using soft surfaces rather than paving to promote percolation, the soaking of water into the soil. Reducing the run-off would also help soil conservation: preventing erosion.

#### 4.4.2 Complex rating systems

Many building energy rating systems are in use worldwide, but recently these have been extended to incorporate ‘greenhouse rating’ and other environmental issues.

In the USA, the Leadership in Environmental and Energy Design (LEED) scheme is in operation. In Australia the Australian

Building Environmental Rating Scheme (ABERS) has recently been introduced.

The Swedish *EcoEffect* rating method is based on a life cycle analysis (LCA). It considers energy use, materials use, indoor and outdoor environment. The various effects are weighted by using a complicated 'analytical hierarchic process'. It is emphasised that the single figure index produced hides the causes and problems, therefore it must be supplemented by 'environmental profiles', stating the criteria and weightings used.

One state government body, Sustainable Development Authority of NSW (SEDA) introduced a Building Greenhouse Rating (BGR) system for commercial buildings, awarding 1–5 stars for poor to exceptionally good buildings. This would distinguish common services, tenants' energy use and Whole Building Rating (WBR). Its major component is energy use, but it includes greenhouse gas emissions, at least in qualitative terms. Star ratings are based on the following criteria:

1 star: POOR

*Poor energy management or outdated systems.* The building is consuming much unnecessary energy. There are cost-effective changes that could be implemented to improve energy consumption, cut operating costs and reduce greenhouse emissions.

2 stars: GOOD

*Average building performance.* The building has some elements of energy efficiency in place and reflects the current market average. There is still scope for cost-effective improvements and minor changes may improve on energy and operating costs.

3 stars: VERY GOOD

*Current market best practice.* The building offers very good systems and management practices and reflects an awareness of the financial and environmental benefits of optimising energy use.

4 stars: EXCELLENT

*Strong performance.* Excellent energy performance due to design and management practices or high efficiency systems and equipment or low greenhouse-intensive fuel supply.

5 stars: EXCEPTIONAL

*Best building performance.* The building is as good as it can be due to integrated design, operation, management and fuel choice.

The assessment of CO<sub>2</sub> emissions is an important contributor to Building Greenhouse Rating.

Table 4.18 gives a summary of numerical limits of CO<sub>2</sub> emissions in terms of kg.CO<sub>2</sub>/m<sup>2</sup> on the basis of which the star ratings would be awarded for office buildings. This is very much a function of climate and as an indication, values for

**Table 4.18** Limits of CO<sub>2</sub> emission for greenhouse rating in kg.CO<sub>2</sub>/m<sup>2</sup>

Stars max:	1	2	3	4	5
Darwin					
Base bldg	148	124	101	77	53
Tenancy	116	96	76	56	36
Whole bldg.	264	220	177	133	89
Brisbane					
Base bldg	215	181	146	112	77
Tenancy	172	142	112	82	53
Whole bldg.	387	323	259	194	130
Melbourne					
Base bldg	225	194	163	132	101
Tenancy	160	137	115	92	70
Whole bldg.	385	331	278	224	171

three states are shown: Darwin, Northern Territory (a hot-humid climate), Brisbane, Queensland (a warm-humid, temperate climate), Melbourne, Victoria (a cool-temperate climate).

#### 4.4.3 Economics

Ecology and economics are often made out to be in opposition to each other. It is worth noting that both words come from the Greek *οικος* (*oikos*), meaning house, habitat or household. The *-logy* ending means *study of ...* whilst the *-nomy* ending implies the *law of ...* So, ecology is the study of and economy is the laws of our house or housekeeping. Perhaps two sides of the same coin?

There are many instances when a slightly increased capital cost would result in substantial savings in running cost. It may be easy to convince a rational-minded client when designing his/her own house to spend a little extra money, say on insulation, which will then reduce the heating costs. Problems may arise when a developer is producing a building for immediate sale, who has no interest in reducing the operating costs. It should be pointed out that buyers now also have a critical attitude and can gauge the added value of an environmentally sound or 'sustainable' building. There is also a prestige value added to such buildings. However, if the architect is acting as an advisor to the buyer, (s)he must be able to ascertain whether the building is really good and 'sustainable' or only claimed to be so. Indeed, the various energy rating systems (discussed in Section 4.2.2.3) may give an indication of the quality of the house considered.

Assessment of investment proposals is usually based on a cost/benefit analysis. Comparing the investment cost with the

longer term benefit. Such a comparison can be done using a discounted cash-flow technique, to find the *present worth* of future savings, to compare it with the extra investment required. Method sheet M.4.1 presents the details of this method.

An alternative to present worth calculations is the LCA. This may include not only the direct cost comparison, but also the maintenance cost of the alternatives and their life expectancy. Very often the appearance, the perceived quality, the prestige value of the alternatives, the expected future re-sale value must also be taken into account. The architect, whether decision maker or advisor, should also be fully aware of locally applicable and current subsidies, incentive schemes, tax benefits which may be applicable to one of the alternatives but not the other.

The economic argument is not necessarily dominant. The Property Council (formerly BOMA, the Building Owners and Managers Association) of Australia found that for 19% of those surveyed, environmental and energy issues are irrelevant to their business and for the others the main reasons for implementing environmental and energy management policies are (in %)

Community relations	39
Competitiveness	24
Market opportunities	23
Shareholder pressure	5
It is irrelevant	9

On the other hand, tenants are keen to have better lighting and thermal conditions (for increased productivity) and to reduce energy consumption (thus operating costs).

The financial balance of such cost/benefit comparisons is often referred to as the 'bottom line'. Recently a new term has been introduced: the 'triple bottom line'. This means an assessment of social value and eco-efficiency in addition to the conventional economic/financial balance.

# REFERENCES

- Ashrae (1972): ASHRAE Handbook of Fundamentals. Atlanta. *Am. Soc. of Heating, Refrigerating and Air- Conditioning Engineers, Inc.*
- Atkinson, G A (1954): *Tropical architecture and building standards*. Proc. 1953 Conf. On Tropical Architecture. Architectural Association, London
- Auliciems, A (1981): Towards a psycho-physiological model of thermal perceptions. *Int. J. of Biometeorology* 25:109–122
- Banham, R (1969): *Architecture of the well-tempered environment*. Architectural Press, London
- Bedford, T (1936): *Warmth factor in comfort at work*. Med. Res. Council, Report 76. HMSO, London
- Beggs, Clive (2002): *Energy management and conservation*. Architectural Press, Oxford
- DeDear, R J, Brager, G and Cooper, D (1997): *Developing an adaptive model of thermal comfort and preference*. Final report, ASHRAE RP-884, Macquarie University
- Du Bois, D and Du Bois E F (1916): A formula to estimate the approximate surface area if height and weight be known. *Archives of Internal Medicine*. 17:863-871
- Farmer, J (1999): *Green shift*. Architectural Press, Oxford
- Gagge, A P, Gonzalez, R R and Nishi, Y (1974): Physiological and physical factors governing man's thermal comfort and heat tolerance. *Build International* 7:305–331
- Gagge, A P, Fobelets, A P and Berglund, L G (1986): A standard predictive index of human response to the thermal environment. *ASHRAE Trans.* vol. 92, pt. 2, p. 709–731
- Givoni, B (1969): *Man, climate and architecture*. Elsevier, Amsterdam.
- Griffiths, I (1990): *Thermal comfort studies in buildings with passive solar features*. Report to CEC, ENS35 090 UK
- Houghten, F C and Yagloglou, C P (1923): Determination of comfort zone, *Trans. Am. Soc. Heat. Vent. Eng.* 29:361
- Humphreys, M (1978): Outdoor temperatures and comfort indoors. *Bldg. Res & Practice* 6(2):92–105
- IES – The Illuminating Engineering Society (1967): Evaluation of discomfort glare: the glare index system. Technical Report No.10. The Society. London
- Koenigsberger, O H, Ingersoll, T G, Mayhew, A and Szokolay, S V (1973): *Manual of tropical housing and building: pt. 1: Climatic design*. Longman, London
- Lawson, Bill (1996): *Building materials, energy and the environment*. RAIA, Canberra
- Longmore, J (1968): *BRS Daylight protractors*. Building Research Station, HMSO, London
- Nicol, F and Roaf, S (1996): Pioneering new indoor temperature standards: the Pakistan project. *Energy and Buildings* 23:169–174
- Olgay, V (1953): Bioclimatic approach to architecture. *Bldg. Res. Adv. Board, Conf. Report No. 5*. National Research Council, Washington DC



## 244 REFERENCES

- Olgay, V (1963): *Design with climate: bioclimatic approach to architectural regionalism*. Princeton University Press, Princeton NJ
- Paix, D (1962–1982): *The design of buildings for daylighting*. Bulletin No. 7, Experimental Building Station, AGPS, Canberra
- Roaf, S, Fuentes, M and Thomas, S (2001): *Ecohouse: a design guide*. Architectural Press, Oxford
- Saini, B S (1973): *Building environment: an illustrated analysis of problems in hot dry lands*. Angus and Robertson, Sydney
- Smith, P (2001): *Architecture in a climate of change*. Architectural Press, Oxford
- Sommer, Robert (1969): *Personal space, The behavioural basis of design*. Prentice-Hall, Englewood Cliffs, NJ
- Szokolay, S V (1980): *Environmental science handbook for architects*. Longman/Construction Press, Lancaster
- Vale, B and Vale, R (1991): *Green architecture: design for a sustainable future*. Thames & Hudson, London
- Vernon, H M and Warner, C G (1932): The influence of humidity of the air on capacity of work at high temperatures. *J. of Hygiene, Camb.* 32:431
- Yaglou, C P (1927): The comfort zone for man. *J. of Industrial Hygiene* 9:251
- Yamaguchi, T (1983): *Windows for passive solar buildings and daylighting*. PhD Thesis, The University of Queensland

# BIBLIOGRAPHY (further reading)

- Baker, N and Steemers, K (1999): *Daylight design of buildings*. James & James, London
- Berge, Bjorn (2001): *Ecology of building materials*. Architectural Press, Oxford
- Clarke, J A (2001): *Energy simulation in buildings design*. Architectural Press, Oxford
- Cowan, HJ (ed.) (1991): *Handbook of architectural technology*. Van Nostrand Reinhold, New York
- Edwards, Brian (1998): *Sustainable architecture, European directives and building design*. Architectural Press, Oxford
- Givoni, B (1994): *Passive and low energy cooling of buildings*. Van Nostrand Reinhold, New York
- Mackenzie, Dorothy (1991): *Green design, Design for the environment*. Laurence King, London
- Slessor, Catherine (1997): *Eco-Tech, Sustainable architecture and high technology*. Thames and Hudson, London
- Steele, James (1997): *Sustainable architecture, Principles, paradigms and case studies*. McGraw-Hill, New York
- Szokolay, S V (1992): *Architecture and climate change*. RAI A. Red Hill, Canberra
- Szokolay, S V (ed.) (1999): *Sustaining the future, Energy – ecology – architecture*. Proc. PLEA'99 Conference. Brisbane. PLEA International & Dept. of Architecture. University of Queensland. Brisbane



# DATA SHEETS AND METHOD SHEETS

D.1.1	Thermal properties of materials	249	D.2.6	Recommended illuminance and limiting glare index values	291
D.1.2	Thermal properties of surfaces and cavities	251	D.2.7	Utilisation factors of typical luminaires	292
D.1.3	Thermal properties of walls	253	D.2.8	Luminaire characteristics: polar curves	294
D.1.4	Thermal properties of windows, roofs and floors	255	D.2.9	Lamp characteristics	295
D.1.5	Thermal Bridges, Ground Floors and Basement Walls	257	M.2.1	Overshadowing: a site survey	297
D.1.6	Solar Gain Factors for Windows	258	M.2.2	Construction of internal perspective (for pepper-pot diagram)	298
D.1.7	Moisture Movement Data	260	M.2.3	Glare index calculation	299
D.1.8	Heat Emission of Humans and Appliances	262	D.3.1	Noise rating (NR) and speech interference level (SIL) limits	301
D.1.9	Typical Ventilation Requirements	264	D.3.2	Attenuation by ground cover and molecular absorption in air	302
M.1.1	Temperature and Vapour Pressure Gradient	266	D.3.3	Transmission loss (dB) of some constructions	303
M.1.2	Stack and Wind Effects	269	D.3.4	Absorption coefficients: materials and components	304
M.1.3	Solar Geometry	271	D.3.5	Absorption coefficients (contd) and Abs of room contents	306
M.1.4	Construction of Stereographic Sun-Path Diagrams	273	M.3.1	Averaging of TL for different wall areas	307
M.1.5	Calculation of Degree-Hours	275	M.3.2	Traffic noise reduction by a barrier	308
M.1.6	Solar Radiation Calculations	277	M.3.3	Calculation of reverberation time	310
M.1.7	Construction of Comfort Zone and Cpzs	279	M.3.4	Progressive rake and principles of optical acoustics	312
M.1.8	Calculation of Dynamic Thermal Properties	281	M.4.1	'Present Worth' and the discounted cash-flow method	314
M.1.9	Determining Shading (Overheated) Period	282			
D.2.1	Daylighting: utilisation factors for roof lights	284			
D.2.2	Daylighting: correction factors	286			
D.2.3	BRS daylight factor protractor no. 2	287			
D.2.4	The internally reflected component (irc) nomogram for daylight factor	288			
D.2.5	The pepper-pot diagram for daylight factor	290			

# DATA SHEET D.1.1

## THERMAL PROPERTIES OF MATERIALS

	Conductivity (W/m K)	Density (kg/m <sup>3</sup> )	Specific heat (J/kg K)
<i>Wall materials</i>			
Adobe blocks	1.250	2050	1000
Brickwork, outer leaf	0.840	1700	800
Brickwork, inner leaf	0.620	1700	800
Brick, sand-lime	1.080	1840	840
Brick, silica	0.890	2240	840
Concrete			
cast, dense	1.400	2100	840
lightweight	0.380	1200	1000
Concrete block, heavy	1.630	2300	1000
Concrete block, medium	0.510	1400	1000
Concrete block, light	0.190	600	1000
Fibreboard (softboard)	0.060	300	1000
Fibrous cement sheet	0.360	700	1050
Fibrous cement decking	0.580	1500	1050
Glass	1.100	2500	840
Plywood	0.138	620	1300
Sand (dry)	0.300	1500	800
Stone			
marble	2.000	2500	900
sandstone	1.300	2000	800
granite	2.300	2600	820
slate	1.530	2950	750
Tile hanging	0.840	1900	800
Plasterboard	0.160	950	840
Timber			
softwood	0.130	610	1420
hardwood	0.150	680	1200
Wood chipboard	0.108	660	1300
<i>Surfacing</i>			
External rendering	0.500	1300	1000
Plastering			
dense	0.500	1300	1000
lightweight	0.160	600	1000
<i>Roof &amp; floor materials</i>			
Asphalt, bitum. felt	0.500	1700	1000
Concrete slab, dense	1.130	2000	1000
Concrete slab, aerated	0.160	500	840
Metal deck	50.000	7800	480
Sand/cement screed	0.410	1200	840
Stone chippings	0.960	1800	1000
Tiles	0.840	1900	800
Thatch (straw)	0.070	240	1420
Timber boarding	0.140	640	1200

	Conductivity (W/m K)	Density (kg/m <sup>3</sup> )	Specific heat (J/kg K)
<i>Insulating materials</i>			
Cork	0.038	144	1800
EPS (exp. polystyrene)	0.035	25	1400
Glass fibre			
quilt	0.040	12	840
batt	0.035	25	1000
Mineral fibre			
slab	0.035	35	1000
same, denser	0.044	150	920
Phenolic foam	0.040	30	1400
Polyurethane board	0.025	30	1400
Strawboard	0.037	250	1050
Same compr, paper faced	0.081	320	1450
Wood wool slab	0.100	500	1000
<i>Loose fills</i>			
Perlite fill, loose	0.046	65	
Cellulose fibre			
fireproofed	0.039	42	
same, denser	0.047	83	
Vermiculite, exfoliated	0.069	128	
<i>Metals</i>			
Aluminium	236	2700	877
Copper	384	8900	380
Zinc	112	7200	390
Iron	78	7900	437
Steel, mild	47	7800	480
Stainless steel	24	7900	510
Lead	37	11300	126

Note that the above are 'declared' conductivity values based on laboratory tests. Before they could be used for calculating U-values, they should be corrected by  $\kappa$  factors as shown in Section 1.1.2.1 and Table 1.2.

**DATA SHEET D.1.2****THERMAL PROPERTIES OF SURFACES AND CAVITIES**

	for 6000°C solar radiation		at 50°C
	Absorptance & emittance	Reflectance	Absorptance & emittance
<i>Radiation properties</i>			
Brick			
white, glazed	0.25	0.75	0.95
light colours	0.40	0.60	0.90
dark colours	0.80	0.20	0.90
Roofs			
asphalt or bitumen	0.90	0.10	0.96
red tiles	0.65	0.35	0.85
white tiles	0.40	0.60	0.50
aluminium, oxidised	0.30	0.80	0.11
bright aluminium, chrome, nickel	0.10	0.90	0.03
bright (new) aluminium foil			0.05
Weathered building surfaces			
light	0.50	0.50	0.60
medium	0.80	0.20	0.95
Paint			
white	0.30	0.70	0.92
matt black	0.96	0.04	0.96
Generally reflectance = $(V \times V - 1)/100$ where V = Munsell value of the paint			
	Normal surfaces	Low emittance surfaces	
<i>Surface resistances (m<sup>2</sup>K/W)</i>			
Inside			
walls	0.12	0.30	
ceiling, floor			
heat flow up	0.10	0.22	
heat flow down	0.14	0.55	
45° ceiling			
heat flow up	0.11	0.24	
heat flow down	0.13	0.39	
Outside			
walls			
sheltered	0.08	0.11	
normal exposure	0.06	0.07	
severe exposure	0.03	0.03	
roofs			
sheltered	0.07	0.09	
normal exposure	0.04	0.05	
severe exposure	0.02	0.02	

	Normal surfaces	Low emittance surfaces
<i>Cavity resistances</i> (m <sup>2</sup> K/W)		
Unventilated		
5 mm cavity, any position	0.10	0.18
>25 mm cavity		
heat flow horizontal	0.18	0.35
heat flow up	0.17	0.35
heat flow down	0.22	1.06
45°, heat flow up	0.19	0.40
45°, heat flow down	0.20	0.98
Multiple foil		
heat flow horizontal or up	—	0.62
heat flow down	—	1.76
Ventilated		
Between fibrous cement sheet ceiling & dark metal roof	0.16	0.30
Between fibrous cement sheet ceiling & fibrous cement roof	0.14	0.25
Between fibrous cement sheet ceiling & tiled roof	0.18	0.26
Between tiles and sarking	0.12	—
Air space behind tile hanging (incl. the tile)	0.12	—
In ordinary cavity walls	0.18	—



**DATA SHEET D.1.3****THERMAL PROPERTIES OF WALLS**

	U-value (W/m <sup>2</sup> K)	Admittance (W/m <sup>2</sup> K)	Time-lag (hours)	Decrement factor
<b>Brick</b>				
single skin, 105 mm	3.28	4.2	2.6	0.87
single skin, 220 mm	2.26	4.7	6.1	0.54
single skin, 335 mm	1.73	4.7	9.4	0.29
single skin, 105 mm plastered	3.02	4.1	3.0	0.83
single skin, 220 mm plastered	2.14	4.5	6.5	0.49
single skin, 335 mm plastered	1.79	4.5	9.9	0.26
cavity, 275 mm plastered	1.47	4.4	7.7	0.44
same, with 25 mm EPS in cavity	0.72	4.6	8.9	0.34
same, with 40 mm EPS in cavity	0.55	4.7	9.1	0.32
same, with 50 mm EPS in cavity	0.47	4.7	9.2	0.31
Brick 105, cavity, 100 Lw concr. block, Lw plaster	0.92	2.2	7.0	0.55
same + 25 mm EPS	0.55	2.3	8.0	0.43
same but 50 mm EPS	0.40	2.4	9.0	0.41
Concr. block solid 200, plasterboard	1.83	2.5	6.8	0.35
same, but foil-backed plasterboard	1.40	1.82	7.0	0.32
same, but 25 cavity, 25 EPS, plasterboard	0.70	1.0	7.3	0.29
same, but lightweight concrete	0.69	1.8	7.4	0.46
same, but foil-backed plasterboard	0.61	1.5	7.7	0.42
same, but 25 cavity, 25 EPS, plasterboard	0.46	1.0	8.3	0.34
concr. block, hollow, 200 mm, ins. plasterboard	2.42	4.1	3.0	0.83
Concrete, dense, cast, 150 mm	3.48	5.3	4.0	0.70
same + 50 mm woodwool slab, plastered	1.23	1.7	6.0	0.50
same, but lightweight plaster	1.15	1.7	6.3	0.49
Concrete, dense, cast, 200 mm	3.10	5.5	5.4	0.56
same + 50 mm woodwool slab, plastered	1.18	2.2	7.7	0.36
same, but lightweight plaster	1.11	1.7	7.6	0.35
Concrete, precast panel, 75 mm	4.28	4.9	1.9	0.91
same + 25 cavity + 25 EPS + plasterboard	0.84	1.0	3.0	0.82
Concrete, precast, 75 + 25 EPS + 150 Lw concr.	0.58	2.3	8.7	0.41
same, but 50 mm EPS	0.41	2.4	9.2	0.35
<i>Brick/block veneers</i>				
Brick 105 + cavity (frame) + plasterboard	1.77	2.2	3.5	0.77
same, but foil-backed plasterboard	1.35	1.7	3.7	0.75
same with 25 mm EPS or glass fibre	0.78	1.1	4.1	0.71
same with 50 mm EPS or glass fibre	0.50	0.9	4.3	0.69
same, 25 EPS + foil-backed plasterboard	0.69	1.0	4.1	0.71
Block 100 + cavity (frame) + plasterboard	1.57	2.1	4.1	0.72
same, but foil-backed plasterboard	1.24	1.7	4.3	0.69
same with 25 mm EPS or glass fibre	0.74	1.1	4.7	0.65
same with 50 mm EPS or glass fibre	0.48	0.9	4.9	0.62
same, 25 EPS + foil-backed plasterboard	0.66	1.0	4.7	0.64

	U-value (W/m <sup>2</sup> K)	Admittance (W/m <sup>2</sup> K)	Time-lag (hours)	Decrement factor
Framed, single fc or galvanised steel	5.16	5.2	0	1
same + cavity + plasterboard	2.20	2.2	0.3	1
same with 25 mm EPS or glass fibre	0.86	1.1	0.5	0.99
same with 50 mm EPS or glass fibre	0.53	0.9	0.7	0.99
Framed, 20 mm timber boarding	3.00	3.0	0.4	1
same + cavity + plasterboard	1.68	1.8	0.8	0.99
same with 25 mm EPS or glass fibre	0.76	1.0	1.0	0.99
same with 50 mm EPS or glass fibre	0.49	0.9	1.2	0.98
Framed, tile-hanging + paper + cavity + 50 EPS + plasterbd	0.54	0.78	1.0	0.99
same, but 100 EPS or glass fibre	0.32	0.71	1.0	0.99
Reverse brick veneer: 5 mm fc + cavity + 105 brick	1.39	4.13	3.70	0.97
same + 25 mm EPS in cavity	0.70	4.53	4.50	0.68
same but 50 mm EPS	0.47	4.62	4.80	0.61
same but only aluminium foil in cavity	1.14	4.22	3.90	0.99
same but both foil and 25 mm EPS	0.63	4.54	4.50	0.70
Reverse block veneer: 5 fc + cavity + 100 hollow block	1.41	3.14	2.20	1.00
same but 100 mm solid concrete block	1.63	6.05	4.40	0.79
same but 50 EPS in cavity + 100 hollow block	0.47	3.59	3.20	0.85
same but 50 EPS in cavity + 100 solid block	0.49	6.45	5.20	0.46
same but 50 EPS in cavity + 200 solid block	0.48	6.16	7.70	0.21

Note: EPS = expanded polystyrene, fc = fibrous cement sheet.

**DATA SHEET D.1.4****THERMAL PROPERTIES OF WINDOWS, ROOFS AND FLOORS**

	U-value (W/m <sup>2</sup> K)	Admittance (W/m <sup>2</sup> K)	Time-lag (hours)	Decrement factor
<i>Windows</i>				
Wood frame, single 6 mm glass	5.0	5.0	0	1
Wood frame, double glazing	2.9	2.9	0	1
Metal frame, single 6 mm glass	6.0	6.0	0	1
same, but discontinuous frame	5.7	5.7	0	1
Metal frame, double glazing	3.6	3.6	0	1
same, but discontinuous frame	3.3	3.3	0	1
Vinyl frame, double (clear + clear) glazing	2.8	2.8	0	1
same, but bronze + clear glass	2.8	2.8	0	1
same, but argon filled clear + clear glazing	1.9	1.9	0	1
same, but argon filled low-e clear + clear	1.7	1.7	0	1
Insulated vinyl frame, krypton fill, triple clear glass	1.9	1.9	0	1
Insulated vinyl frame, krypton fill, triple (2 low-e) glass	0.8	0.8	0	1
Roof glazing single 6 mm glass	6.6	6.6	0	1
Roof glazing double glazing	4.6	4.6	0	1
Horizontal daylight + skylight, ventilated	3.8	3.8	0	1
same but unventilated	3.0	3.0	0	1
<i>Flat roofs</i>				
150 concr. slab, plastered, 75 screed + asphalt	1.80	4.50	8	0.33
same, but lightweight concrete	0.84	2.30	5	0.77
25 timber deck, bit. felt, plasterboard ceiling	1.81	1.90	0.9	0.99
same + 50 mm EPS	0.51	0.80	1.3	0.98
10 fc. deck, 13 fibreboard, asphalt, fc. ceiling	1.50	1.90	2	0.96
50 ww, 13 screed, 20 asph, plasterboard ceiling	1.00	1.40	3	0.93
13 fibreb'd, 20 asph, 10 foil-back plasterboard	1.20	1.30	1	0.99
Metal deck, 25 EPS, bitumenous felt	1.10	1.20	1	0.99
same + 13 fibreboard + plasterboard ceiling	0.73	0.91	1	0.99
same, but 50 mm EPS	0.48	0.75	1	0.98
<i>Pitched roofs</i>				
Corrugated fibrous cement sheet	4.9	4.9	0	1
same + attic + plasterboard ceiling	2.58	2.6	0.3	1
same + 50 mm EPS or glass fibre	0.55	1	0.7	0.99
Tiles, sarking + attic + plasterboard ceiling	2.59	2.6	0.5	1
same + 50 mm EPS or glass fibre	0.54	1.0	1.5	0.97
Tiles, sarking, 25 timber ceiling (sloping)	1.91	2.1	1.0	0.99
same + 50 mm EPS or glass fibre	0.51	1.5	1.4	0.97
Metal sheet (corrugated or profiled)	7.14	7.1	0	1
Metal sheet + attic + plasterboard ceiling	2.54	2.6	0.3	1
same + 50 mm EPS or glass fibre	0.55	1.0	0.7	0.99

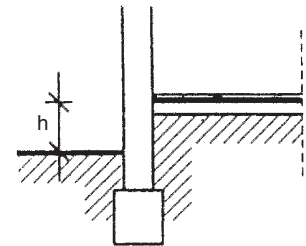
	U-value (W/m <sup>2</sup> K)	Admittance (W/m <sup>2</sup> K)	Time-lag (hours)	Decrement factor
<i>Floors</i>				
Suspended timber, bare or lino				
3 × 3 m	1.05	2.0	0.7	0.99
7.5 × 7.5 m	0.68	2.0	0.8	0.98
15 × 7.5 m	0.61	2.0	0.8	0.98
15 × 15 m	0.45	2.0	0.9	0.97
30 × 15 m	0.39	2.0	0.9	0.97
60 × 15 m	0.37	2.0	1.0	0.97
Concrete slab on ground, 2 edges exposed				
3 × 3 m	1.07	6.0	—	0.01
6 × 6 m	0.57	6.0	—	0
7.5 × 7.5 m	0.45	6.0	—	0
15 × 7.5 m	0.36	6.0	—	0
15 × 15 m	0.26	6.0	—	0
30 × 15 m	0.21	6.0	—	0
60 × 15 m	0.18	6.0	—	0
100 × 40 m	0.09	6.0	—	0
Concrete slab on ground, 4 edges exposed				
3 × 3 m	1.47	6.0	—	0.02
6 × 6 m	0.96	6.0	—	0.01
7.5 × 7.5 m	0.76	6.0	—	0.01
15 × 7.5 m	0.62	6.0	—	0
15 × 15 m	0.45	6.0	—	0
30 × 15 m	0.36	6.0	—	0
60 × 15 m	0.32	6.0	—	0
100 × 40 m	0.16	6.0	—	0

Note: fc = fibrous cement.

# DATA SHEET D.1.5

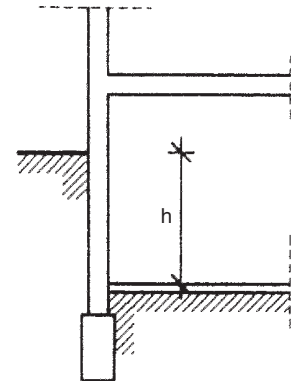
## THERMAL BRIDGES, GROUND FLOORS AND BASEMENT WALLS

Linear heat loss coefficients	k
Window perimeter	0.15 W/m K
Same, but if window is in the plane of insulation and joint sealed	0
Outer corner of homogeneous wall	0.10
Outer corner of wall with external insulation	0.15
External wall with internal insulation	0
Joint of homogeneous external wall and internal wall (both edges counted)	0.12
Joint of ext. wall with ext. insulation and internal wall (both edges counted)	0.06
Joint of homog. ext. wall & floor slab with insul. strip (both edges counted)	0.15
Joint of ext. wall with ext. insulation and floor slab (both edges counted)	0.06
Parapet wall, cornice	0.20
Projecting balcony slab	0.3



h = ground level to floor level distance

On-ground floor losses		linear heat transmission coefficients (W/m K)								
Height [h] relative to ground level (m)	If floor thermal resistance is [m <sup>2</sup> K/W]									
	No insul.	0.2–0.35	0.4–0.55	0.6–0.75	0.8–1.0	1.05–1.5	1.55–2	2.05–3		
> 6.0	0	0	0	0	0	0	0	0		
–6.00 to –4.05	0.20	0.20	0.15	0.15	0.15	0.15	0.15	0.15		
–4.00 to –2.55	0.40	0.40	0.35	0.35	0.35	0.35	0.30	0.30		
–2.50 to –1.85	0.60	0.55	0.55	0.50	0.50	0.45	0.45	0.40		
–1.80 to –0.25	0.80	0.70	0.70	0.65	0.60	0.60	0.55	0.45		
–1.20 to –0.75	1.00	0.90	0.85	0.80	0.75	0.70	0.65	0.55		
–0.70 to –0.45	1.20	1.05	1.00	0.95	0.90	0.80	0.75	0.65		
–0.40 to –0.25	1.40	1.20	1.10	1.05	1.00	0.90	0.80	0.70		
–0.20 to +0.20	1.75	1.45	1.35	1.25	1.15	1.05	0.95	0.85		
+0.25 to +0.40	2.10	1.70	1.55	1.45	1.30	1.20	1.05	0.95		
+0.45 to +1.00	2.35	1.90	1.70	1.55	1.45	1.30	1.15	1.00		
+1.05 to +1.50	2.55	2.05	1.85	1.70	1.55	1.40	1.25	1.10		



Losses through earth sheltered walls		linear heat transmission coefficients (W/m K)								
Height [h] below ground level (m)	If U-value of wall itself is [W/m <sup>2</sup> K]									
	0.4–0.49	0.5–0.6	0.85–0.79	0.8–0.99	1–1.19	1.2–1.49	1.5–1.79	1.8–2.2		
>6.0	1.40	1.65	1.85	2.05	2.25	2.45	2.65	2.80		
6.00 to 5.05	1.30	1.50	1.70	1.90	2.05	2.25	2.45	2.65		
5.00 to 4.05	1.15	1.35	1.50	1.65	1.90	2.05	2.24	2.45		
4.00 to 3.05	1.00	1.15	1.30	1.45	1.65	1.85	2.00	2.20		
3.00 to 2.55	0.85	1.00	1.15	1.30	1.45	1.65	1.80	2.00		
2.50 to 2.05	0.70	0.85	1.00	1.15	1.30	1.45	1.65	1.80		
2.00 to 1.55	0.60	0.70	0.85	1.00	1.10	1.25	1.40	1.55		
1.50 to 1.05	0.45	0.55	0.65	0.75	0.90	1.00	1.15	1.30		
1.00 to 0.75	0.35	0.40	0.50	0.60	0.65	0.80	0.90	1.05		
0.70 to 0.45	0.20	0.30	0.35	0.40	0.50	0.55	0.65	0.75		
0.40 to 0.25	0.10	0.15	0.20	0.25	0.30	0.35	0.40	0.45		



**DATA SHEET D.1.6****SOLAR GAIN FACTORS FOR WINDOWS**

	Instantaneous (sgf or $\theta$ )	Alternating (asg)		
		Lightweight	Heavyweight	
<i>Single glazing</i>				
Clear, 6 mm glass	0.76	0.64	0.47	
Surface tinted 6 mm glass (STG)	0.60	0.53	0.41	
Body tinted 6 mm glass (BTG)	0.52	0.47	0.38	
Body tinted 10 mm glass (BTG)	0.42	0.39	0.34	
Clear glass, with reflective film	0.32	0.29	0.23	
Same but strongly reflective film	0.21	0.19	0.16	
Clear, with tinted reflective film	0.28	0.26	0.23	
Reflecting glass	0.36	0.33	0.27	
Strongly reflecting glass	0.18	0.17	0.15	
<i>Double glazing (outer pane first)</i>				
Clear 6 mm + clear 6 mm	0.64	0.56	0.42	
STG + clear 6 mm	0.48	0.43	0.34	
BTG 6 mm + clear 6 mm	0.40	0.37	0.30	
BTG 10 mm + clear 6 mm	0.30	0.28	0.24	
Reflecting + clear 6 mm	0.28	0.25	0.21	
Strongly reflecting + clear 6 mm	0.13	0.12	0.10	
Lightly reflecting sealed double unit	0.32	0.29	0.21	
Strongly reflecting sealed double unit	0.15	0.14	0.11	
<i>Single glazing + External shade</i>				
Clear 6 mm	+ light horizontal slats <sup>+</sup>	0.16	0.11	0.09
	+ light vertical slats <sup>+</sup>	0.18	0.13	0.10
	+ dark horizontal slats <sup>+</sup>	0.13	0.09	0.08
	+ holland blind	0.13	0.10	0.08
	+ miniature louvres*	0.16	0.10	0.09
	+ miniature louvres**	0.12	0.09	0.08
	BTG			
+ light horizontal slats <sup>+</sup>	0.13	0.09	0.08	
	+ light vertical slats <sup>+</sup>	0.14	0.12	0.09
<i>Double glazing + External shade</i>				
Clear 6 + clear 6	+ light horizontal slats <sup>+</sup>	0.13	0.09	0.07
	+ light vertical slats <sup>+</sup>	0.15	0.10	0.08
	+ light roller blind	0.10	0.09	0.07
	+ miniature louvres*	0.12	0.07	0.06
	+ miniature louvres**	0.09	0.06	0.06
	+ dark horizontal slats <sup>+</sup>	0.10	0.06	0.06
<i>Triple glazing</i>				
Clear 6 + clear 6 + clear 6		0.55	0.50	0.39
	+ mid-pane light slats	0.28	0.26	0.24
<i>Single glazing + Internal shade</i>				
Clear 6 mm	+ light horizontal slats <sup>+</sup>	0.31	0.28	0.24
	+ light vertical slats <sup>+</sup>	0.32	0.30	0.24
	+ dark horizontal slats <sup>+</sup>	0.35	0.36	0.34
	+ linen blind	0.20	0.18	0.14

		Instantaneous (sgf or $\theta$ )	Alternating (asg)	
			Lightweight	Heavyweight
BTG 6 mm	+ light slatted blind <sup>+</sup>	0.19	0.18	0.17
BTG 10 mm	+ light slatted blind <sup>+</sup>	0.14	0.14	0.13
Reflecting	+ light slatted blind <sup>+</sup>	0.14	0.14	0.12
Strongly reflecting	+ light slatted blind <sup>+</sup>	0.06	0.06	0.06
<i>Double glazing + Internal shade</i>				
Clear 6 + clear 6				
	+ light slatted blind <sup>+</sup>	0.26	0.25	0.21
	+ dark slatted blind <sup>+</sup>	0.30	0.31	0.30
	+ mid-pane light slats	0.28	0.26	0.24
BTG 6 mm + clear 6 mm	+ light slatted blind <sup>+</sup>	0.15	0.14	0.13
BTG 10 mm + clear 6 mm	+ light slatted blind <sup>+</sup>	0.10	0.10	0.09
Reflecting + clear 6 mm	+ light slatted blind <sup>+</sup>	0.11	0.10	0.09
Strongly reflecting + clear 6 mm	+ light slatted blind <sup>+</sup>	0.04	0.04	0.04

\* 1.5 mm spacing; width/spacing ratio: 0.85; blade tilt: 20°; absorptance: 0.96.

\*\* 1.1 mm spacing; width/spacing ratio: 1.15; blade tilt: 20°; absorptance: 0.98.

<sup>+</sup> width/spacing ratio: 1.2; blade tilt: 45°; absorptance, light: 0.4, dark: 0.8.

Note: BTG = body tinted glass, STG = surface tinted glass.



# DATA SHEET D.1.7

## MOISTURE MOVEMENT DATA

---

### A Indoor moisture production

One person		
At rest	40 g/h	
Sedentary activity	50 g/h	
Active	200 g/h	
Cooking (gas)		
Breakfast	400 g	} 3000 g/day
Lunch	500 g	
Dinner	1200 g	
Dishwashing		
Breakfast	100 g	
Lunch	100 g	
Dinner	300 g	
Floor mopping	1100 g	
Clothes washing	2000 g	
Clothes drying (indoors)	12 000 g	
Shower	200 g	
Bath	100 g	

### B Permeability ( $\delta$ ) of some materials

Brickwork	0.006–0.042 mg/s.m.kPa or $\mu\text{g/s.m.Pa}$
Cement render	0.010
Concrete	0.005–0.035
Cork board	0.003–0.004
Expanded ebonite (Onozote)	<0.0001
Expanded polystyrene	0.002–0.007
Fibreboard (softboard)	0.020–0.070
Hardboard	0.001–0.002
Mineral wool	0.168
Plastering	0.017–0.025
Plasterboard	0.017–0.023
Plywood	0.002–0.007
Polyurethane foam	
Open cell	0.035
Closed cell	0.001
Strawboard	0.014–0.022
Timber	
Air dry	0.014–0.022
Wet	0.001–0.008
Wood wool slab	0.024–0.070

**C Permeance ( $\pi$ ) of some elements and surfaces**

Aluminium foil	<0.006 mg/s.m <sup>2</sup> kPa or $\mu$ g/s.m <sup>2</sup> Pa
Bituminous paper	0.09
Brickwork 105 mm	0.04–0.06
Concrete blocks 200 mm hollow	0.14
Cement render, or screed	
25 mm, 4:1	0.67
25 mm, 1:1	0.40
Corkboard 25 mm	0.40–0.54
Kraft paper	
single	4.54
3-ply	2.00
5-ply	1.60
Oil paint,	
2 coats on plaster	0.09–0.17
3 coats on wood	0.02–0.06
Plaster on lath	
25 mm	0.63
20 mm	0.83
12 mm	0.93
Plasterboard 10 mm	1.7–2.80
Plywood	
external quality 6 mm	0.026–0.041
internal quality 6 mm	0.106–0.370
Polyethylene film 0.06 mm	0.004
Softwood (pine)	
25 mm	0.08
12 mm	0.10–0.17
Strawboard 50 mm	0.13–0.26
Wood wool slab 25 mm	3.08–4.14
Surface	
internal	25
external	100

Vapour resistance is the reciprocal of permeance:  $vR = 1/\pi$  or  $vR = b/\delta$ .

Note: any layer of less than 0.067 mg/s.m<sup>2</sup>kPa permeance is taken as a vapour barrier.

**DATA SHEET D.1.8****HEAT EMISSION OF HUMANS AND APPLIANCES**

	(at 20°C)			(at 26°C)	
	Total	Sensible	Latent	Sensible	Latent
<b>Heat output of human bodies</b>					
(in <b>W</b> (watts))					
Seated at rest	115	90	25	65	50
Sedentary work	140	100	40	70	70
Seated, eating	150	85	65	70	80
Slow walking	160	110	50	75	85
Light bench type work	235	130	105	80	55
Medium work	265	140	125	90	175
Heavy work	440	190	250	105	335
Very heavy work (gymnasium)	585	205	380	175	420
<i>Electric lighting load</i>				<b>W/(m<sup>2</sup> lux)</b>	
<hr/>					
Incandescent					
open enamelled reflector				0.125–0.160	
general diffusing				0.160–0.225	
Fluorescent					
white, open trough				0.037	
enclosed, diffusing				0.050	
louvred, recessed				0.055	
de luxe warm white, enclosed, diffusing				0.075–0.100	
louvred, recessed				0.085–0.110	
Mercury MBF, industrial reflector				0.050–0.075	
<hr/>					
<i>Electrical appliances</i>		<b>Sensible (W)</b>		<b>Latent (W)</b>	
<hr/>					
Hair dryer (blower)		700		100	
Hair dryer (helmet type)		600		100	
Coffee urn					
14 L		800		500	
23 L		1000		700	
Computer (PC)					
main unit		200–300		—	
VDU (CRT), VGA		150–300		—	
printer		30–300		—	
Food warmer per m <sup>2</sup> top surface		1000		1000	
Frying pot (300 × 350 mm)		1100		1700	
Grill, meat (250 × 300 cooking area)		1200		600	
Grill, sandwich (300 × 300 cooking area)		800		200	
Jug or kettle		≈1800		500	
Microwave oven		≈1300		—	
Refrigerator					
1 door, manual		150–260		—	
2 door, auto defrost		350–400		—	
2 door, frost-free		500–600		—	

	Sensible (W)	Latent (W)
Sterilizer, bulk (600 × 600 × 900)	10000	6500
Sterilizer, water, 45 L	1200	4800
Sterilizer, water, 70 L	1800	7200
Sterilizer, instrument (150 × 100 × 450)	800	700
(250 × 300 × 900)	3000	2700
Toaster, pop-up (2 slices)	700	200
Toaster, continuous (2 slices)	1500	400
Toaster, continuous (4 slices)	1800	800
Vacuum cleaner	600–1200	—
Waffle iron	400	200
Water heater (domestic)	2400–3600	—
<i>Gas appliances</i>	Sensible (W)	Latent (W)
Coffee urn		
14 L	900	900
23 L	1200	1200
Food warmer per m <sup>2</sup> top surface	2700	1600
Frying pot 280 × 410 mm	2100	1400
Grill, top burner 0.13 m <sup>2</sup> surface	4400	1100
Toaster, continuous (2 slices)	2200	1000
Laboratory burners (bunsen) 10 mm dia. (natural gas)	500	100
Stove, short order, closed top per m <sup>2</sup> top surface	11 000	11 000
Same open top	13 500	13 500

# DATA SHEET D.1.9

## TYPICAL VENTILATION REQUIREMENTS

Air inhaled	at sedentary activity	0.5 m <sup>3</sup> /h
	at heavy work, up to	5 m <sup>3</sup> /h
Limitation	CO <sub>2</sub> content, absolute limit	0.5%
	markedly 'used air' effect	0.15%
If room volume per person (m <sup>3</sup> )	Then fresh air supply rate per person	
	Minimum	Recommended
3	12	17
6	7	11
9	5	8
12	4	6
Kitchen, other than domestic	20 air changes per hour	
Kitchen, domestic	10	
Laundry, boiler room, operating theatre	15	
Canteen, restaurant, dance hall	10–15	
Cinema, theatre, lavatory	6–10	
Bathroom, bank hall, parking station	6	
Office, laboratory	4–6	
Library	3–4	
Staircase, corridor (non-domestic)	2	
All other domestic rooms	1	
Requirement	If area/pers.	Room occupancy type (examples only)
4 L/s pers	given number	Sauna, steam room
10 L/s pers	given number	Dormitory, ticket booth
	0.6 m <sup>2</sup>	Transport concourse, platform, funeral chapel
	1 m <sup>2</sup>	Rest room, shops fitting room, kiosk, funeral reception room
	1.5 m <sup>2</sup>	Medical waiting room, museum exhibition area, broadcast studio
	2 m <sup>2</sup>	School classroom >16y, music room, locker room, waiting area
	5 m <sup>2</sup>	Shops sales floor, arcade, office art room, physiotherapy room
		Drawing office, library, coin-op. laundry, pharmacy
	10 m <sup>2</sup>	Photo dark room, florist, dry cleaner, hotel bedroom, general office
		Bank vault, residential buildings
	20 m <sup>2</sup>	Warehouse
	25 m <sup>2</sup>	Computer room
	50 m <sup>2</sup>	Hangar
12 L/s pers	2 m <sup>2</sup>	School classrooms < 16y
15 L/s pers	0.6 m <sup>2</sup>	Theatre, opera, concert hall, foyer, lecture hall
	1 m <sup>2</sup>	Cafeteria, fast food, large assembly room, disco, conference room
	2 m <sup>2</sup>	Small conference room
	4 m <sup>2</sup>	Theatre, concert hall, lecture hall, hairdresser shop, beauty salon
	5 m <sup>2</sup>	Hotel suite living room, theatre 'green room', prison cell block

Requirement	If area/pers.	Room occupancy type (examples only)
20 L/s pers	1 m <sup>2</sup>	Bar, cocktail lounge
	1.5 m <sup>2</sup>	Cabaret
	2 m <sup>2</sup>	Air traffic control room
	5 m <sup>2</sup>	Medical buildings: delivery and operating room
25 L/s pers	1.5 m <sup>2</sup>	Smoking room
50 L/s pers	5 m <sup>2</sup>	Autopsy room
On a floor area basis		
1 L/s.m <sup>2</sup>		Corridor, foyer, lobby, stairs, pedestrian tunnel, utility room
3.5 L/s.m <sup>2</sup>		Pool area, deck
4 L/s.m <sup>2</sup>		Electricity meter or switch room, fire control room
5 L/s.m <sup>2</sup>		Veterinary kennel, animal room, operating room, pet shop

# METHOD SHEET M.1.1

## TEMPERATURE AND VAPOUR PRESSURE GRADIENT

Add the resistances of all layers. Divide the overall temperature difference by this total resistance. This is the 'unit drop', i.e. the temperature drop per unit resistance. Multiplied by the resistance of each layer, this will give the temperature drop for each layer. Starting with the indoor temperature, subtract the temperature drops to get the temperature at each layer junction point. From this the temperature gradient can be plotted.

Repeat the same procedure for vapour resistance, vapour pressure drop and vapour pressure at each layer junction point. The corresponding dew point temperature (DPT) is to be read from the psychrometric chart.

The method is illustrated by an example:

Take a simple cavity wall, which consists of a 110 mm brick outer skin and an inner skin of 100 mm AAC (aerated autoclaved concrete, such as Thermalite or Hebel blocks), with a 12 mm plastering on the inside.

Assume  $T_i = 22^\circ\text{C}$  and  $T_o = 0^\circ\text{C}$ ,  $v_{p_i} = 1.34 \text{ kPa}$ ,  $v_{p_o} = 0.4 \text{ kPa}$ .

	Temperature gradient			Vapour pressure gradient			
	R	$\Delta T$	T at junction	vR	$\Delta vp$	vp	DPT at junction
Outside air			$0^\circ\text{C}$			$0.4 \text{ kPa}$	$-5.0^\circ\text{C}$
External surface	0.06	1.42 K	1.42	0.01	0.001 kPa	0.401	-4.8
Brick: $\frac{b}{\lambda} = \frac{0.110}{0.84} = 0.13$	0.13	3.07	4.49	$\frac{b}{\delta} = \frac{0.110}{0.02} = 5.50$	0.538	0.939	6.4
Cavity	0.18	4.26	8.75	0.02	0.002	0.941	6.5
AAC $\frac{0.100}{0.24} = 0.42$	0.42	9.94	18.69	$\frac{0.100}{0.03} = 3.33$	0.326	1.267	10.6
Plaster $\frac{0.012}{0.5} = 0.02$	0.02	0.47	19.16	$\frac{0.012}{0.017} = 0.71$	0.069	1.336	11.5
Internal surface	0.12	2.84	22	0.04	0.004	1.340	11.7
Inside air							
	0.93	22 K		9.61	0.94 kPa		
as $\Delta T = 22 \text{ K}$ , the 'unit drop' is $\frac{22}{0.93} = 23.65$ the T drop in each layer is $R \times 23.65$			as $\Delta vp = 1.34 - 0.4 = 0.94 \text{ kPa}$ thus the 'unit drop' is $\frac{0.94}{9.61} = 0.098$ thus the drop in vapour pressure in each layer is $vR \times 0.098$				

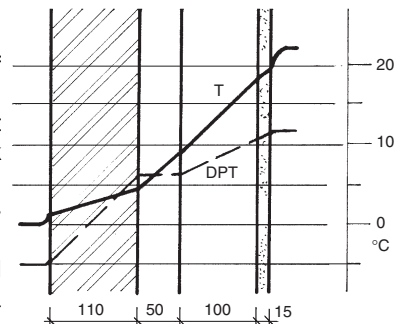
The R,  $\lambda$ , vR and  $\delta$  values are taken from data sheets D.1.2 and D.1.6.

Where the temperature T, drops below the DPT, there is a risk of condensation.

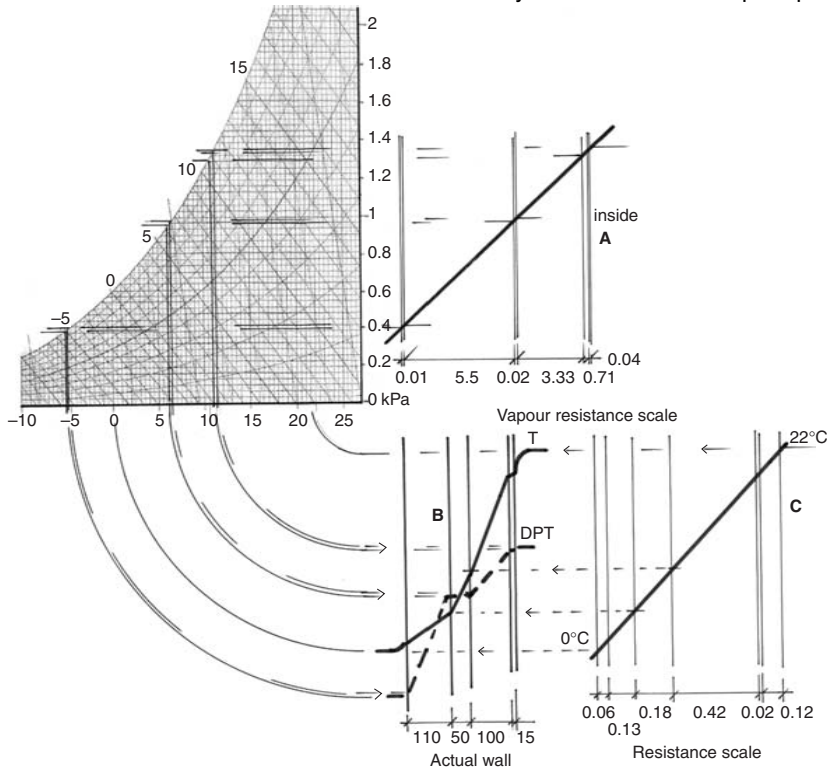
From the plot of the T and DPT profiles on a cross-section of the wall, it will be seen that there is a condensation risk at the inside face of the brick skin.

The gradients can also be determined graphically. This is best introduced by continuing the above example.

The overall vapour resistance is 9.61. Draw the thickness of the wall and its layers to a suitable vapour resistance scale. Here we assume a



scale of 5 mm = 1 vR unit, so the total 'thickness' is 48 mm. Draw this section (**A**) alongside a part of the psychrometric chart, so that the vapour pressure scale of that chart (in kPa) can be used for the vertical scale in this section. Mark the level of internal vapour pressure on the inside surface of this section and the outdoor vapour pressure on the outside surface. Connect these two points by a straight line: the intersection with each boundary line will mark the vapour pressure at that plane.



To convert these vapour pressures to DPT values, project all intersection points across to the saturation curve of the psychrometric chart. Project these intersections vertically down to the base line, where the DPTs can be read.

It may be convenient to use this (horizontal) temperature scale also in a vertical position, with the physical section of the wall. In the diagram below quadrant arcs have been used to translate the scale into vertical, to an actual section of the wall (**B**), here drawn to a scale of 1:10. The DPTs can be transferred to this section, and will define the DPT gradient.

A third section should be drawn alongside the above, where the thickness is scaled to the thermal resistance of each layer. A scale of 10 mm to 0.1 resistance unit ( $m^2K/W$ ) is convenient. (**C**) The vertical (temperature) scale should be shared with the actual section. If the indoor and outdoor temperature points are marked on the surfaces and connected by a straight line, the intersection of this with each layer boundary will determine the temperature at that point. The line connecting these points will be the temperature gradient across the wall.

Wherever the dew-point gradient dips below the temperature gradient, there will be a condensation risk (in this case at the inside surface of the outer brick skin).



# METHOD SHEET M.1.2

## STACK AND WIND EFFECTS

### Stack effect

Air flow in a stack is driven by the density difference between inside and outside air.

The density of air at 0°C is  $d_o = 1.293 \text{ kg/m}^3$   
and at any other temperature T:  

$$d_T = 1.293 * 273/T. \quad (1)$$
 where T is absolute temperature in °K

The gravitational acceleration is  $g = 9.81 \text{ m/s}^2$   
The 'stack pressure' ( $p_i - p_o$ ) is  

$$\Delta p = h * g * (d_o - d_i)$$

$$\Delta p = h * 9.81 * (1.293 * 273/T_o - 1.293 * 273/T_i)$$

$$\Delta p = h * 3462 * (1/T_o - 1/T_i). \quad (2)$$

$$(as \ 9.81 * 1.293 * 273 = 3462)$$

where T is in °K

height (h) is in m (between centres of inlet and outlet) then  $\Delta p$  is in Pa (Pascal)

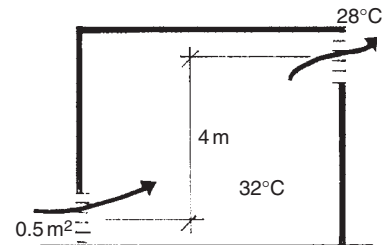
A useful rule-of-thumb is that  $\Delta p \approx 0.13 \text{ Pa/K}$  for each storey height.

The volume flow rate will then be 
$$vr = 0.827 * A * \sqrt{\Delta p}. \quad (3)$$

where A is in  $\text{m}^2$  and vr is in  $\text{m}^3/\text{s}$

If apertures are in series (e.g. inlet and outlet)

then the effective area will be 
$$A' = \frac{A_1 + A_2}{\sqrt{A_1^2 + A_2^2}}$$



e.g. if  $T_o = 28^\circ\text{C} = 301^\circ\text{K}$ , which gives a density of  $1.293 * 273/301 = 1.173 \text{ kg/m}^3$

$T_i = 32^\circ\text{C} = 305^\circ\text{K}$ , which gives a density of  $1.293 * 273/305 = 1.157 \text{ kg/m}^3$

and if  $h = 4 \text{ m}$

then  $\Delta p = 4 * 3462 * (1/301 - 1/305) = 0.6 \text{ Pa}$  or  $\Delta p = 4 * 9.81 * (1.173 - 1.157) = 0.6 \text{ Pa}$

and if inlet = outlet = shaft cross sectional area:  $A = 0.5 \text{ m}^2$

then  $vr = 0.827 * 0.5 * \sqrt{0.6} = 0.32 \text{ m}^3/\text{s}$  or 320 L/s

### Wind effect

The pressure of wind is  $p_w = 0.5 * d * v^2$

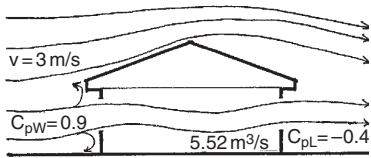
where d = density, as above (often taken as  $1.224 \text{ kg/m}^3$

corresponding to  $15^\circ\text{C}$ )

v = velocity in m/s

thus generally taken as

$$p_w = 0.612 * v^2 \quad (4)$$



For a building surface this must be multiplied by a pressure coefficient  $c_p$  typical values of which are  
 on windward side  $c_{pW} = 0.5$  to  $0.1$   
 on leeward side  $c_{pL} = -0.3$  to  $-0.4$   
 Cross ventilation is driven by the wind pressure difference

$$\Delta p_w = \rho_w * (c_{pW} + c_{pL}) \tag{5}$$

and the resulting volume flow rate will be

$$v_r = 0.827 * A * c_e * \sqrt{\Delta p_w} \tag{6}$$

where  $A$  = effective area of openings (as above)  
 $c_e$  = 'effectiveness coefficient'  
 values of which are  
 from 0.1 if windows in one wall only (no cross ventilation)  
 to 1 full cross ventilation, equal inlet & outlet, no partitions.

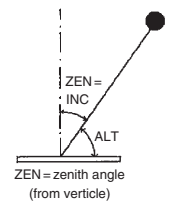
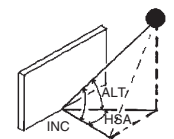
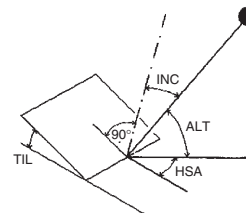
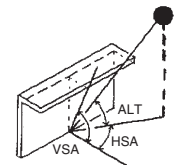
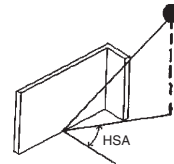
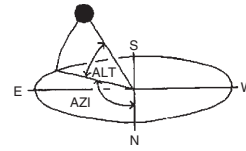
e.g: if  $v = 3 \text{ m/s}$   
 $c_{pW} = 0.9$   
 $c_{pL} = -0.4$   
 then  $\Delta p_w = 0.612 * 3^2 * [0.9 - (-0.4)]$   
 $= 0.612 * 9 * 1.3 = 7.16 \text{ Pa}$   
 and if  $A = 3 \text{ m}^2$   
 $c_e = 1$  (full cross ventilation)  
 then  $v_r = 0.827 * 3 * 1 * \sqrt{7.16}$   
 $= 6.64 \text{ m}^3/\text{s}$

# METHOD SHEET M.1.3

## SOLAR GEOMETRY

### Definitions

- AZI = solar azimuth (0 to 360°)
- ALT = solar altitude (from horizontal; zenith= 90°)
- ZEN = zenith angle (from the vertical); ZEN = 90 – ALT
- ORI = orientation (azimuth of the surface normal, 0 to 360°)
- HSA = horizontal shadow angle (azimuth difference)
- VSA = vertical shadow angle (on perpendicular normal plane)
- INC = angle of incidence (from the surface normal)
- LAT = geographical latitude (south negative)
- DEC = declination (between the earth-sun line and the equator plane)
- HRA = hour angle from solar noon, 15° per hour
- SRA = sunrise azimuth, i.e. azimuth at sunrise time
- SRT = sunrise time



### Expressions

$$DEC = 23.45 * \sin[0.986 * (284 + NDY)] \quad (\text{result in degrees})$$

where NDY = number of day of year  
 $0.986 = 360^\circ / 365 \text{ days}$   
 or more accurately:

$$DEC = 0.33281 - 22.984 * \cos N + 3.7872 * \sin N - 0.3499 * \cos(2 * N) + 0.03205 * \sin(2 * N) - 0.1398 * \cos(3 * N) + 0.07187 * \sin(3 * N)$$

where  $N = 2 * \pi * NDY / 366$  (result in radians)

$$HRA = 15 * (\text{hour} - 12)$$

$$ALT = \arcsin(\sin DEC * \sin LAT + \cos DEC * \cos LAT * \cos HRA)$$

$$AZI = \arcsin \frac{\cos LAT * \sin DEC - \cos DEC * \sin LAT * \cos HRA}{\cos ALT}$$

gives result 0 – 180°, i.e. for a.m. only  
 for p.m. take  $AZI = 360 - AZI$  (as found from the above expression)

- HSA = AZI – ORI
- if  $90^\circ < \text{abs}|HSA| < 270^\circ$   
 then sun is behind the facade, it is in shade
- if  $HSA > 270^\circ$  then  $HSA = HSA - 360^\circ$
- if  $HSA < -270^\circ$  then  $HSA = HSA + 360^\circ$

$$\text{VSA} = \arctan \frac{\tan \text{ALT}}{\cos \text{HSA}}$$

$$\text{INC} = \arcsin (\sin \text{ALT} * \cos \text{TIL} + \cos \text{ALT} * \sin \text{TIL} * \cos \text{HSA})$$

where TIL = tilt angle of receiving plane from the horizontal

For vertical planes, as TIL = 90, cos TIL = 0, sin TIL = 1:

$$\text{INC} = \arcsin(\cos \text{ALT} * \cos \text{HSA})$$

For a horizontal plane:

$$\text{INC} = \text{ZEN} = 90 - \text{ALT}$$

$$\text{SRA} = \arcsin (\cos \text{LAT} * \sin \text{DEC} + \tan \text{LAT} * \tan \text{DEC} * \sin \text{LAT} * \cos \text{DEC})$$

$$\text{SRT} = 12 - \frac{\arcsin(-\tan \text{LAT} * \tan \text{DEC})}{15}$$


---

# METHOD SHEET M.1.5

## CONSTRUCTION OF STEREOGRAPHIC SUN-PATH DIAGRAMS

- 1 Draw a circle of selected radius ( $r$ ), most often taken as 75 mm (150 mm diameter). Draw a horizontal and a vertical diameter to indicate the four compass points. Extend the vertical one in the polar direction, to give the locus for the centres of all sun-path arcs.
- 2 For each sun-path arc (each date) calculate its radius ( $r_s$ ) and the distance of its centre from the centre of the circle ( $d_s$ )

$$r_s = r * \frac{\cos DEC}{\sin LAT + \sin DEC} \quad d_s = r * \frac{\cos LAT}{\sin LAT + \sin DEC}$$

where LAT = geographical latitude  
DEC = solar declination angle

March 21 and Sep 23	DEC = 0°
June 22	DEC = 23.45°
December 22	DEC = -23.45°

for intermediate lines the following dates are suggested:

May 12 + Aug 1	DEC = 18°
Apr 14 + Aug 28	DEC = 9°
Nov 11 + Jan 30	DEC = -18°
Oct 14 + Feb 27	DEC = -9°

- 3 For the construction of the hour lines calculate the distance of the locus of centres from the centre of the circle ( $d_t$ ) and draw this locus parallel to the east-west axis:

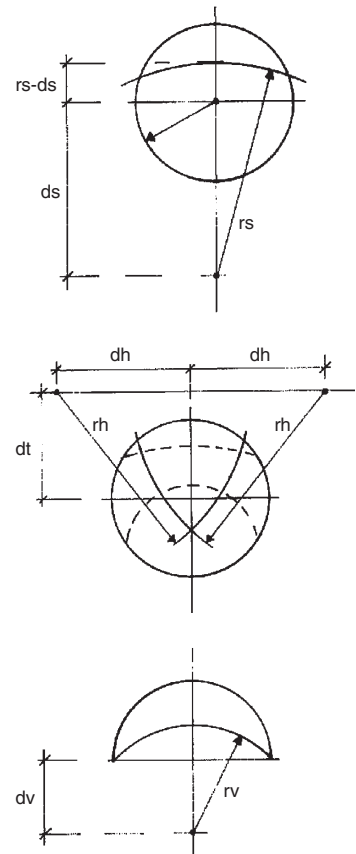
$$d_t = r * \tan LAT$$

For each hour calculate the horizontal displacement of the centre from the vertical centreline ( $d_h$ ) and the radius of the hour-arc: ( $r_h$ ):

$$d_h = \frac{r}{\cos LAT * \tan HRA} \quad r_h = \frac{r}{\cos LAT * \sin HRA}$$

where HRA hour angle from noon, 15° for each hour  
eg. for 8:00 h: HRA = 15 \* (8-12) = -60°  
for 16:00 h: HRA = 15 \* (16-12) = 60°

Draw the arcs for afternoon hours from a centre on the right-hand side and for the morning hours from the left-hand side. A useful check is that the 6:00 and 18:00 h lines should meet the equinox sun-path at exactly the east and west points respectively.



- 4 Mark the azimuth angles on the perimeter at any desired increments from 0 to 360° (north) and construct a set of concentric circles to indicate the altitude angle scale.

For any altitude (ALT) the radius will be

$$ra = r * \frac{\cos ALT}{1 + \sin ALT}$$

- 5 For a **shadow angle protractor** draw a semi-circle to the same radius as the chart. Extend the vertical axis downwards to give the locus for the centres of all VSA (vertical shadow angle) arcs. For each chosen increment of VSA find the displacement of the centre (dv) and the radius of the arc: (rv):

$$dv = r * \tan VSA \quad rv = \frac{r}{\cos VSA}$$

- 6 Mark the HSA (horizontal shadow angle) scale along the perimeter: the centreline is zero, then to 90° to the right (clockwise) and to -90° to the left (anticlockwise). A useful check is that along the centreline of the protractor the VSA arcs should coincide with the corresponding altitude circles of the sun-path diagram.

# METHOD SHEET M.1.5

## CALCULATION OF DEGREE-HOURS

*Heating degree-Hours for a month*

Data required:  $\bar{T}$  = outdoor mean temperature  
 $T_{sd}$  = standard deviation of temperatures  
 $T_b$  = base temperature (e.g. the lower comfort limit)

let  $dT$  be  $T_b - \bar{T}$

$X$  be  $dT/T_{sd}$

The probability density function is

$$\phi = \frac{1}{\sqrt{2 * \pi} * \exp[-(X^2/2)]}$$

if  $t$  is taken as

$$t = \frac{1}{1 + 0.33267 * X}$$

then the 'tail area' will be

$$AT = \phi * (0.43618 * X - 0.12016 * X^2 + 0.93729 * X^3)$$

(a numerical approximation of the integral)

The fraction below the base temperature will be

$$\text{if } dT > 0 \text{ then } \phi = 1 - AT$$

$$\text{otherwise } \phi = AT$$

Finally

$$Kh = 24 * N * (\phi * dT + T_{sd} * \phi)$$

where  $N$  = number of days in the month

e.g. for Canberra, July

$$\bar{T} = 5.3^\circ\text{C}$$

$$T_{sd} = 2.7 \text{ K}$$

$$T_b = 15.4^\circ\text{C}$$

$$dT = 15.4 - 5.3 = 10.1$$

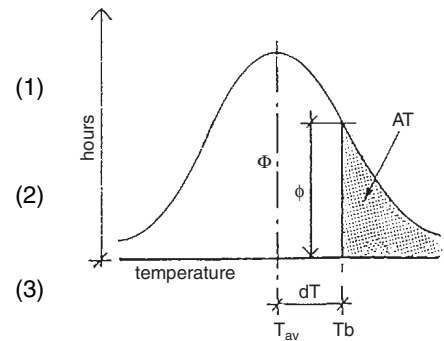
$$X = \frac{10.1}{2.7} = 3.74$$

$$\text{as } \frac{1}{\sqrt{2 * \pi}} = 0.3989$$

$$\phi = 0.3989 * \exp[-(3.74^2/2)] = 0.000365$$

$$t = \frac{1}{1 + 0.33267 * 3.74} = 0.45$$

$$AT = 0.000365 * (0.43618 * 0.45 - 0.12016 * 0.45^2 + 0.93729 * 0.45^3) = 9.25 * 10^{-5}$$



The 'bell curve' of temperature distribution (normal or Gaussian distribution is assumed).

(4)

as  $10.1 > 0$

$$P = 1 - AT = 0.9999$$

$$Kh = 24 * 31 * (0.9999 * 10.1 + 2.7 * 0.000365) = 7514$$

---

The assumption behind Eq. (4) above is that  $Kh = 24 \times Kd$  is not always true.

A correction term (add) may have to be added to the Kh value thus obtained.

(1) if  $T_{\max} > T_b > \bar{T}$  then  $r = T_{\max} - T_b$

(2) if  $\bar{T} > T_b > T_{\min}$  then  $r = T_b - T_{\min}$

$$\text{add} = N \times r^2 \pi / 2$$

in the above example (Canberra, July)

$$T_{\max} = 11.1^\circ\text{C}$$

$$T_{\min} = -0.5^\circ\text{C}$$

$$T_b = 15.4^\circ\text{C}$$

$$\bar{T} = 5.3^\circ\text{C}$$

neither of the two conditions apply, thus there is no need for correction.

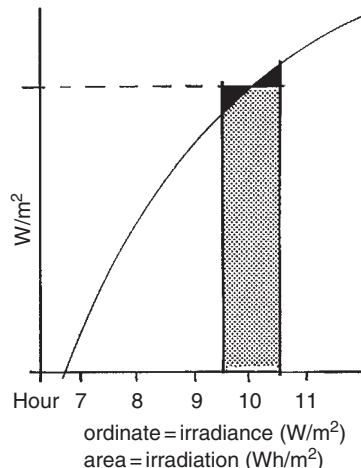
---



# METHOD SHEET M.1.6

## SOLAR RADIATION CALCULATIONS

<i>Notation</i>	G = irradiance or power density ( $W/m^2$ ) D = irradiation ( $Wh/m^2$ ) over a specified period, e.g. day or month
first subscript	b = beam (direct) d = diffuse r = reflected if none, then it means Global (surface of incidence)
second subscript	n = normal to the direction of the beam p = on a plane (to be defined) v = vertical (e.g. $G_{v270}$ = irradiance of a west-facing vertical plane) h = horizontal (may be omitted)
TIL = tilt angle of a plane from the horizontal $\rho$ = (rho) reflectance	



If daily total horizontal irradiation ( $D_h$ ) is given for an average day of the month

- 1 estimate beam and diffuse components of the total
  - (a) find extraterrestrial irradiance ( $W/m^2$ ) normal to the direction of radiation

$$G_{on} = 1353 * [1 + 0.033 * \cos(2 * \pi * NDY/365.24)]$$

where  $NDY$  = number of day of the year, taken for mid-month

- (b) the daily total irradiation ( $Wh/m^2$ ) on a horizontal plane will be

$$D_h = (24/\pi) * \cos LAT * \cos DEC * (\sin SSH - SSH \cos SSH)$$

where  $LAT$  = latitude,  $DEC$  = solar declination (see M.1.3)

$SSH$  = sunset hour angle =  $\arccos(-\tan LAT * \tan DEC)$

- (c) the atmospheric clearness index is  $k' = D_h/D_{oh}$
- (d) the diffuse fraction will be

$$\text{if } j = SSH - 0.5 * \pi$$

$$df = 0.775 + 0.347 * j - (0.505 + 0.261 * j) * \cos[2 * (k' - 0.9)]$$

- (e) then the diffuse component will be  $D_{dh} = D_h * df$
- (f) and the beam component  $D_{bh} = D_h - D_{dh}$

- 2 estimate hourly values of global radiation and of diffuse component

- (a) pre-calculate five factors

$$f1 = \sin(SSH - 1.047)$$

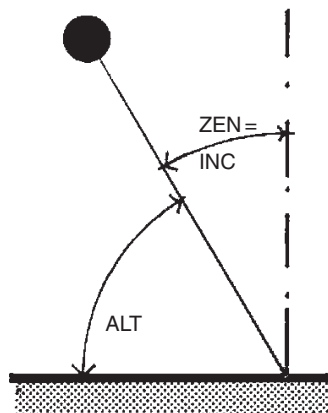
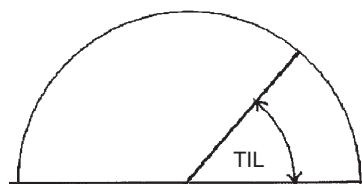
$$f2 = 0.409 + 0.5016 * f1$$

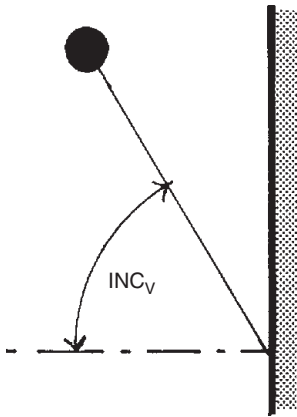
$$f3 = 0.6609 - 0.4767 * f1$$

$$f4 = (\pi/24) / [\sin SSH - (SSH * \cos SSH)]$$

- (b) for each hour from sunrise to sunset the fraction of the day's total for that time  $r(t)$  will be

$$f5 = \cos HRA - \cos SSH$$





fraction of total:  $rt_t = f4 * f5 * (f2 + f3 * \cos HRA)$

fraction of diffuse:  $rf_t = f4 * f5$

(c) total irradiation for the hour  $Dh_t = Dh * rt_t$

diffuse irradiation for the hour  $Dd_t = Ddh * rf_t$

the beam component will be the difference between the two

$$Db_t = Dh_t - Dd_t$$

Generally

$$G = Gb + Gd(+Gr)$$

Diffuse

$$Gdv = Gdh * 0.5$$

$$Gdp = Gdh * (1 + \cos TIL)/2$$

when  $TIL = 0$ , then  $\cos TIL = 1$ ,

$$(1 + 1)/2 = 1$$

when  $TIL = 90^\circ$  then  $\cos TIL = 0$ ,

$$(1 + 0)/2 = 0.5$$

Reflected

$$Grv = Gh * \rho * 0.5$$

$$Grp = Gh * \rho * (1 - \cos TIL)/2$$

when  $TIL = 0$ , then  $\cos TIL = 1$ ,

$$(1 - 1)/2 = 0$$

when  $TIL = 90^\circ$  then  $\cos TIL = 0$ .

$$(1 - 0)/2 = 0.5$$

Horizontal/normal

$$Gh = Gn * \cos ZEN$$

$$Gn = Gh / \cos ZEN$$

$$= Gh * \sin ALT \text{ (as } ALT = 90^\circ - ZEN)$$

*Beam*

vertical/normal  $Gbv = Gn * \cos INCv$

$$= Gh * \cos INCv / \sin ALT$$

$$Gbp = Gh * \cos INCp / \sin ALT$$

*Total*

$$Gp = Gh * \cos INCp / \sin ALT + Gdh * (1 + \cos TIL)/2$$

$$+ Gh * \rho * (1 - \cos TIL)/2$$

$$Gv = \cos INCv / \sin ALT + Gdh * 0.5 + Gh * \rho * 0.5$$

# METHOD SHEET M.1.7

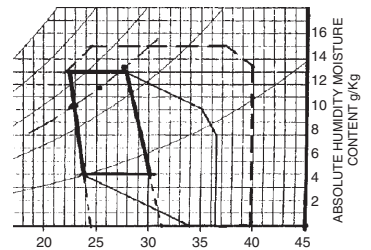
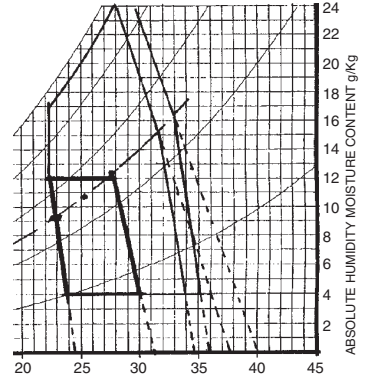
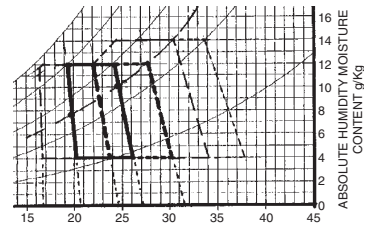
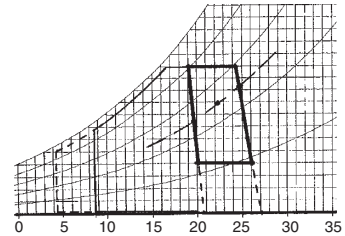
## CONSTRUCTION OF COMFORT ZONE AND CPZS

- (1) Establish the mean temperature of the warmest and coldest months ( $T_{av}$ )
- (2) Find the neutrality temperature for both, from  $T_n = 17.6 + 0.31 * T_{av}^{\circ}C$  and the limits of comfort upper:  $T_U = T_n + 2.5^{\circ}C$  lower:  $T_L = T_n - 2.5^{\circ}C$  mark these on the 50% RH curve
- (3) Construct the corresponding sloping SET lines by determining the X-axis intercept (T) from  $T = T_U + 0.023 * (T_U - 14) * AH_{50}$  where  $AH_{50}$  is the absolute humidity (g/kg) at the RH 50% level at the  $T_U$  temperature this can be read from the psychrometric chart (Fig. 1.14) or calculated as half of the saturation humidity. The saturation vapour pressure is  $p_{vs} = 0.133322 * \exp[18.6686 - 4030.183 / (T_U + 235)]$  saturation humidity will be  $sh = 622 * p_{vs} / (101.325 - p_{vs})$  and  $AH_{50} = 0.5 * sh$  repeat for  $T_L$  + repeat both for the coldest month

limiting temperature =  $T_U$  + amplitude e.g. for Brisbane

Jan:  $25.0^{\circ}C$  Jul:  $15.1$   
 $T_n = 17.6 + 0.31 * 25.0 = 25.4^{\circ}C$   
 $T_n = 17.6 + 0.31 * 15.1 = 22.3^{\circ}C$

Jan	Jul
$T_U = 27.9$	$24.8^{\circ}C$
$T_L = 22.9$	$19.8$
$p_{vsU} = 3.75$	$3.13 \text{ kPa}$
$p_{vsL} = 2.79$	$2.72$
$sh_U = 23.9$	$19.8 \text{ g/kg}$
$sh_L = 17.6$	$17.2$
<b><math>AH_{50}</math>:</b>	
$U = 11.9$	$9.9 \text{ g/kg}$
$L = 8.8$	$8.6$
intercept	
$U = 31.7$	$27.2^{\circ}C$
$L = 24.7$	$20.9$



**Passive solar heating CPZ**  
 in relation to the July comfort zone  
 (see also Example 1.7 in Section 1.5.1.1)  
 the extension is  
 with

$\eta = 0.5 \quad 0.0036 * D_{v,360}$   
 $\eta = 0.7 \quad 0.005 * D_{v,360}$

draw vertical lines at these limiting temperatures  
 the upper limit will be the 95% RH curve

**Mass effect CPZ**  
 for summer in relation to the  
 January comf. zone

$D_{v,360} = 3094 \text{ Wh/m}^2$   
 limiting temperatures:  
 $16.7 - 0.0036 * 3094 = 8.7^{\circ}C$

$16.7 - 0.005 * 3094 = 4.3^{\circ}C$

$T_{max} = 29.1^{\circ}C$   
 $T_{min} = 21.0^{\circ}C$

'amplitude' = $(T_{max} - T_{min}) * 0.3$	(1) $(29.1 - 21) * 0.3 = 2.4$ K
with night vent: $(T_{max} - T_{min}) * 0.6$	(2) $(29.1 - 21) * 0.6 = 4.8$
limiting temperature = $T_U + \text{amplitude}$	limiting temperatures:
draw corresponding SET lines	(1) _____ (2) _____
as in (3) above	
	27.9 + 2.4 = 30.3 32.7°C
the upper boundary of the CPZ is the	$p_{vs} = 4.32$ 4.94 kPa
14 g/kg	
repeat for 'winter'	sh = 27.7 31.8 g/kg
in relation to the July comfort zone	AH <sub>50</sub> = 13.8 15.9 g/kg
CPZ to the left	intercepts:
mark the limiting temperature on the	35.5 39.5°C
50% RH curve	
find the X-axis intercept as in (3) above	$T_{max} = 20.4^\circ\text{C}$
draw the (near vertical) side boundary	$T_{min} = 9.8^\circ\text{C}$
the top boundary cannot be	$(20.4 - 9.8) * 0.3 = 3.2$ K
higher than the	
95% RH curve	limiting temperature
<i>Air movement effect</i>	$19.8 - 3.2 = 16.6^\circ\text{C}$
for summer, in relation to the	
January comf. zone	
for 1 & 1.5 m/s, effective	dT = 3.8 and 5.1 K
velocities 0.8 & 1.3 m/s	
apparent cooling effects dT	limiting temperatures
(from eq. 1.21)	
limiting temperatures: $T_U + dT$	(1 m/s) _____ (1.5 m/s) _____
mark these on the 50% RH curve	31.7°C 33°C
find the X-axis intercept as in (3) above	$p_{vs} = 4.67$ 5.03 kPa
draw the boundary from this	sh = 30 32.5 g/kg
intercept upwards	
from the 50% curve only	AH <sub>50</sub> = 15 16.2 g/kg
for the lower half take half of	intercepts:
this intercept	
the top limit is the 95% RH curve	37.8 40°C
<i>Evaporative cooling</i>	
take lower left corner of	T = 24°C, AH = 4 g/kg
January comfort zone	X-axis intercept:
draw the corresponding WBT	$24 + 4 * (2501 - 1.805 * 24) / 1000$
line to the X-axis	
X-intercept	
= $T + AH * (2501 - 1.805 * T) / 1000$	
draw parallel line from top	= $24 + 9.8 = 33.8^\circ\text{C}$
right corner of comf.zn.	
the temperature limit is the vertical at	$25.4 + 11 = 36.4^\circ\text{C}$
$T_n + 11^\circ\text{C}$	
for indirect this is at	$24.4 + 14 = 39.4^\circ\text{C}$
$T_n + 14^\circ\text{C}$ and the upper	
boundary is the 14 g/kg horizontal line	corners rounded off



## METHOD SHEET M.1.8

### CALCULATION OF DYNAMIC THERMAL PROPERTIES

**Diffusivity** is a composite index of material properties:

$$\alpha = \frac{\lambda}{\rho \cdot c} \quad \text{dimensionally } m^2/h \quad (1)$$

The **decrement factor**, for solid homogeneous elements will be

$$\mu = \exp\left(-b\sqrt{\frac{\pi}{\alpha \cdot 24}}\right) \quad (2)$$

but as  $\sqrt{\frac{\pi}{24}} = 0.362$   $\mu = \exp\left(-0.362 \cdot b\sqrt{\frac{1}{\alpha}}\right)$

and the **time-lag** is

$$\phi = \frac{b}{2}\sqrt{\frac{24}{\pi \cdot \alpha}} \quad (3)$$

and as  $\frac{1}{2} \cdot \sqrt{\frac{24}{\pi}} = 1.38$   $\phi = 1.38 \cdot b\sqrt{\frac{1}{\alpha}}$

As the angular velocity of the diurnal temperature wave is  $\omega = (2 \cdot \pi/24)$  this can be substituted into both Eqs (2) and (3), together with the  $\alpha$  expression Eq. (1), thus we get alternative forms for both  $\mu$  and  $\phi$ :

$$\mu = \exp\left(-b \cdot \sqrt{\frac{\omega \cdot \rho \cdot c}{2 \cdot \lambda}}\right) \quad (4)$$

$$\phi = b \cdot \sqrt{\frac{\rho \cdot c}{2 \cdot \lambda \cdot \omega}} \quad (5)$$

where  $b$  = thickness of element (m);  $\lambda$  = thermal conductivity (W/m K);  $\rho$  = density (kg/m<sup>3</sup>);  $c$  = specific heat capacity (Wh/kg K).

Note that if the latter is given in J/kg K, then the day length (24 h) must be given in seconds (24 • 3600).

**Admittance**, for a solid homogeneous element is

$$Y = \sqrt{\lambda \cdot \rho \cdot c \cdot \omega} \quad (6)$$

and using consistent SI units, dimensionally this is W/m<sup>2</sup>K

Some authors use the concept of **time constant**, the product of resistance and thermal capacity:

$$\gamma = \frac{b}{\lambda} \cdot b \cdot \rho \cdot c = \frac{b^2 \cdot \rho \cdot c}{\lambda} \quad \text{and if the } \alpha \text{ term is substituted it becomes}$$

$$\gamma = \frac{b^2}{\alpha}, \quad \text{and taken for unit area, its dimension will be h (hour)}$$

The **thermal inertia index** is a non-dimensional index number, the ratio of admittance (Y) to the U-value (both are in units of W/m<sup>2</sup>K)

# METHOD SHEET M.1.9

## DETERMINING SHADING (OVERHEATED) PERIOD

Solar heat input is definitely desirable when  $T_o$  is below the lower comfort limit and can be tolerated up to  $T_o = T_n$  (as long as outdoor temperature is less than the neutrality).

Take Phoenix (AZ), latitude  $33.5^\circ$ , as an example. The printout shows hourly temperatures for an average day of each month, the neutrality (Eq. (1.7) Section 1.2.3) and the  $\pm 2.5\text{K}$  comfort limits.  $T_n$  varies between  $21^\circ\text{C}$  (Jan) and  $27.7^\circ\text{C}$  (July). The lower limit in January is  $18.5^\circ\text{C}$ . Below this solar heat input is wanted. Above  $27.7^\circ\text{C}$  shading is a must. The most likely shading limit (a compromise) may be around the  $21^\circ\text{C}$  curve. These three isopleths are plotted on a month  $\times$  hour chart.

Month/hrs	1	2	3	4	5	6	7	8	9	10	11	12	13	14	15	16	17	18	19	20	21	22	23	24	av.
1:	7.1	6.1	5.2	4.5	4.1	4.0	4.5	6.1	8.3	11.0	13.7	15.9	17.5	18.0	17.9	17.5	16.8	15.9	14.9	13.7	12.4	11.0	9.6	8.3	11.0
2:	9.3	8.2	7.3	6.6	6.1	6.0	6.6	8.2	10.6	13.5	16.4	18.8	20.4	21.0	20.9	20.4	19.7	18.8	17.7	16.4	15.0	13.5	12.0	10.6	13.5
3:	11.6	10.3	9.3	8.6	8.2	8.0	8.6	10.3	12.9	16.0	19.1	21.7	23.4	24.0	23.8	23.4	22.7	21.7	20.4	19.1	17.6	16.0	14.4	12.9	16.0
4:	14.6	13.5	12.7	12.2	12.0	12.5	13.9	16.0	18.6	21.4	24.0	26.1	27.5	28.0	27.8	27.3	26.5	25.4	24.0	22.5	20.8	19.2	17.5	16.0	20.0
5:	18.8	17.6	16.7	16.2	16.0	16.5	18.0	20.2	23.0	26.0	28.8	31.0	32.5	33.0	32.8	32.3	31.4	30.2	28.8	27.1	25.4	23.6	21.9	20.2	24.5
6:	22.9	21.8	21.2	21.0	21.4	22.6	24.5	26.9	29.5	32.1	34.5	36.4	37.6	38.0	37.8	37.2	36.1	34.8	33.2	31.4	29.5	27.6	25.8	24.2	29.5
7:	27.5	26.4	25.6	25.2	25.0	25.5	26.8	28.8	31.2	33.8	36.2	38.2	39.5	40.0	39.8	39.4	38.6	37.5	36.2	34.8	33.3	31.7	30.2	28.8	32.5
8:	26.3	25.3	24.6	24.2	24.0	24.4	25.6	27.5	29.8	32.2	34.5	36.4	37.6	38.0	37.8	37.4	36.7	35.7	34.5	33.2	31.7	30.3	28.8	27.5	31.0
9:	23.5	22.4	21.6	21.2	21.0	21.5	22.8	24.8	27.2	29.8	32.2	34.2	35.5	36.0	35.8	35.4	34.6	33.5	32.2	30.8	29.3	27.7	26.2	24.8	28.5
10:	16.8	15.5	14.4	13.6	13.2	13.0	13.6	15.5	18.2	21.5	24.8	27.5	29.4	30.0	29.8	29.4	28.6	27.5	26.2	24.8	23.2	21.5	19.8	18.2	21.5
11:	10.8	9.5	8.4	7.6	7.2	7.0	7.6	9.5	12.2	15.5	18.8	21.5	23.4	24.0	23.8	23.4	22.6	21.5	20.2	18.8	17.2	15.5	13.8	12.2	15.5
12:	8.2	7.0	6.0	5.1	4.5	4.1	4.0	4.7	6.8	9.8	13.2	16.2	18.3	19.0	18.9	18.5	17.9	17.0	16.0	14.8	13.6	12.2	10.8	9.4	11.5

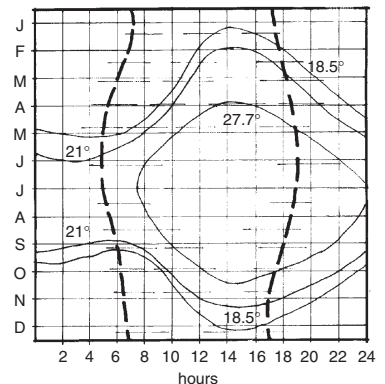
Other temperatures and outdoor Kelvin-hours

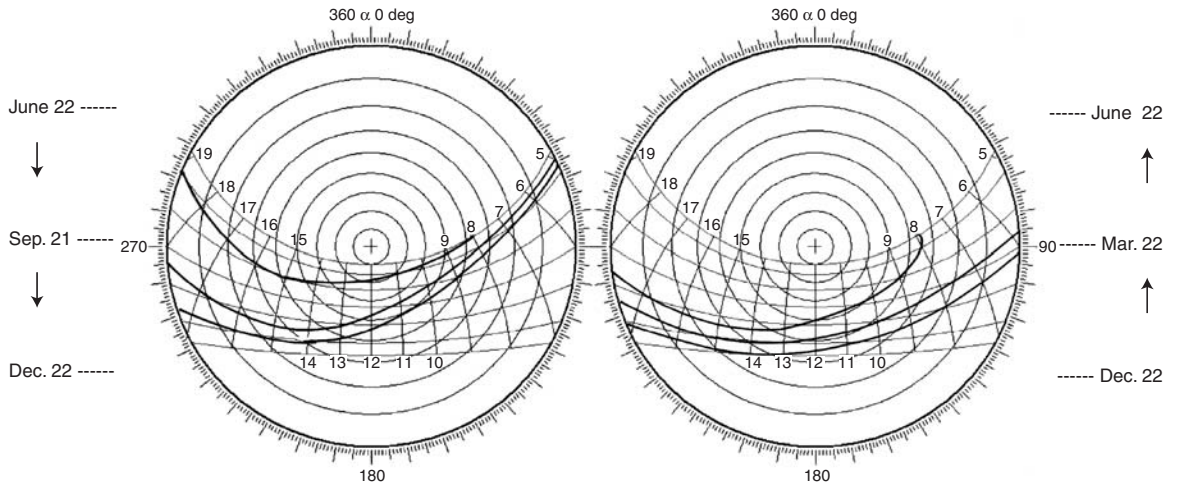
	Jan	Feb	Mar	Apr	May	Jun	Jul	Aug	Sep	Oct	Nov	Dec
T upper limit	23.5	24.3	25.1	26.3	27.7	29.2	30.2	29.7	28.9	26.8	24.9	23.7
T neutrality	21.0	21.8	22.6	23.8	25.2	26.7	27.7	27.2	26.4	24.3	22.4	21.2
T lower limit	18.5	19.3	20.1	21.3	22.7	24.2	25.2	24.7	23.9	21.8	19.9	18.7

On the sun-path diagram the long east–west arcs correspond to the month lines of these isopleth chart and the short north–south curves are the hour lines. So the above isopleths can be transferred onto this ‘twisted’ chart base, except that each sun-path curve is valid for two dates, thus two solar charts must be used, one from December to June and the other from July to December.

Outside the  $18.5^\circ\text{C}$  curve solar input is welcome. Inside the  $27.7^\circ\text{C}$  curve solar input must be prevented. The boundary of the shading period will probably be around the  $21^\circ\text{C}$  curve, but it could be anywhere between the  $18.5^\circ\text{C}$  and  $27.7^\circ\text{C}$  isopleths, depending on the particular conditions. It can be noted that the Dec.–June half year requires less shading than the June–Dec. half (temperatures are lagging behind solar heating by 4–6 weeks) thus the solution will have to be a compromise between the spring and autumn limits.

The final decision can only be made when building (window) orientation and the form of shading system are considered. The shading can be designed as discussed in Section 1.4.1.1 and the example shown in Fig. 1.46, using the shadow angle protractor laid over these sun-path diagrams.



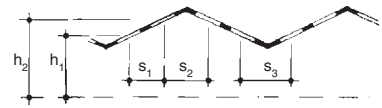




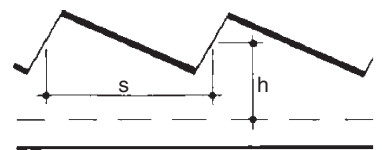
# DATA SHEET D.2.1

## DAYLIGHTING: UTILISATION FACTORS FOR ROOF LIGHTS

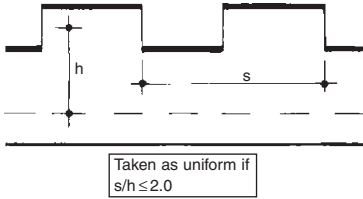
Surface reflectances									
Ceiling	0.7			0.5			0.3		
Walls	0.5	0.3	0.1	0.5	0.3	0.1	0.5	0.3	0.1
Utilisation factors									
<i>Shed roof</i>									
0.6	0.34	0.30	0.27	0.34	0.30	0.27	0.30	0.27	0.27
0.8	0.40	0.39	0.36	0.40	0.39	0.36	0.39	0.36	0.35
1.0	0.45	0.43	0.41	0.44	0.42	0.41	0.42	0.41	0.38
1.25	0.50	0.47	0.46	0.50	0.47	0.45	0.47	0.45	0.44
1.5	0.52	0.49	0.47	0.51	0.49	0.47	0.49	0.46	0.46
2.0	0.57	0.55	0.53	0.56	0.53	0.52	0.53	0.52	0.51
2.5	0.59	0.56	0.55	0.59	0.56	0.55	0.55	0.52	0.52
3.0	0.62	0.60	0.59	0.62	0.59	0.58	0.59	0.58	0.56
4.0	0.64	0.63	0.61	0.64	0.63	0.61	0.61	0.60	0.60
5.0	0.68	0.65	0.65	0.66	0.65	0.63	0.63	0.62	0.62
Infinite	0.76	0.76	0.76	0.74	0.74	0.74	0.73	0.73	0.71
<i>Saw-tooth roof (vertical)</i>									
0.6	0.07	0.06	0.04	0.07	0.05	0.04	0.05	0.03	0.03
0.8	0.11	0.08	0.07	0.10	0.08	0.06	0.08	0.06	0.05
1.0	0.14	0.11	0.10	0.13	0.10	0.09	0.10	0.08	0.07
1.25	0.16	0.13	0.12	0.15	0.13	0.11	0.12	0.10	0.09
1.5	0.17	0.15	0.13	0.16	0.14	0.12	0.13	0.12	0.10
2.0	0.19	0.17	0.16	0.18	0.16	0.15	0.15	0.14	0.12
2.5	0.21	0.20	0.18	0.20	0.18	0.17	0.17	0.16	0.14
3.0	0.22	0.21	0.19	0.21	0.19	0.18	0.18	0.17	0.15
4.0	0.24	0.22	0.21	0.22	0.21	0.20	0.19	0.18	0.17
5.0	0.25	0.24	0.23	0.23	0.22	0.21	0.20	0.18	0.18
Infinite	0.30	0.30	0.30	0.29	0.29	0.29	0.27	0.27	0.27
<i>Saw-tooth roof (sloping)</i>									
0.6	0.19	0.16	0.15	0.19	0.16	0.17	0.16	0.14	0.14
0.8	0.25	0.21	0.20	0.25	0.21	0.20	0.21	0.20	0.18
1.0	0.30	0.26	0.25	0.29	0.26	0.24	0.25	0.24	0.21
1.25	0.31	0.30	0.27	0.31	0.29	0.26	0.27	0.26	0.24
1.5	0.34	0.31	0.30	0.32	0.31	0.29	0.30	0.27	0.26
2.0	0.36	0.35	0.32	0.36	0.34	0.32	0.34	0.32	0.29
2.5	0.39	0.38	0.35	0.38	0.36	0.34	0.35	0.32	0.31
3.0	0.40	0.39	0.38	0.40	0.36	0.36	0.36	0.35	0.32
4.0	0.42	0.41	0.40	0.41	0.40	0.39	0.39	0.38	0.35
5.0	0.44	0.42	0.41	0.42	0.41	0.40	0.40	0.39	0.36
Infinite	0.49	0.49	0.49	0.48	0.48	0.48	0.45	0.45	0.42



Taken as uniform if  
 $s_1/h_1 \leq 1.4$   
 $s_2/h_2 \leq 1.9$   
 $s_3/h_1 \leq 21.2$



Taken as uniform if  
 $s/h \leq 1.5$



Surface reflectances									
Ceiling	0.7				0.5				0.3
Walls	0.5	0.3	0.1	0.5	0.3	0.1	0.5	0.3	0.1

RI	Utilisation factors								
<i>Monitor roof (vertical)</i>									
0.6	0.07	0.05	0.04	0.06	0.05	0.04	0.05	0.04	0.03
0.8	0.09	0.07	0.06	0.09	0.07	0.06	0.07	0.06	0.05
1.0	0.12	0.10	0.08	0.11	0.09	0.08	0.09	0.08	0.07
1.25	0.14	0.12	0.10	0.13	0.11	0.10	0.11	0.10	0.09
1.5	0.15	0.13	0.12	0.15	0.13	0.12	0.13	0.11	0.11
2.0	0.17	0.15	0.14	0.16	0.15	0.14	0.15	0.13	0.13
2.5	0.18	0.17	0.15	0.18	0.16	0.15	0.16	0.15	0.14
3.0	0.20	0.18	0.17	0.19	0.18	0.17	0.17	0.16	0.16
4.0	0.21	0.20	0.19	0.20	0.19	0.19	0.19	0.18	0.17
5.0	0.22	0.21	0.20	0.21	0.20	0.19	0.20	0.19	0.18
Infinite	0.25	0.25	0.25	0.25	0.25	0.25	0.24	0.24	0.23

## DATA SHEET D.2.2

### DAYLIGHTING: CORRECTION FACTORS

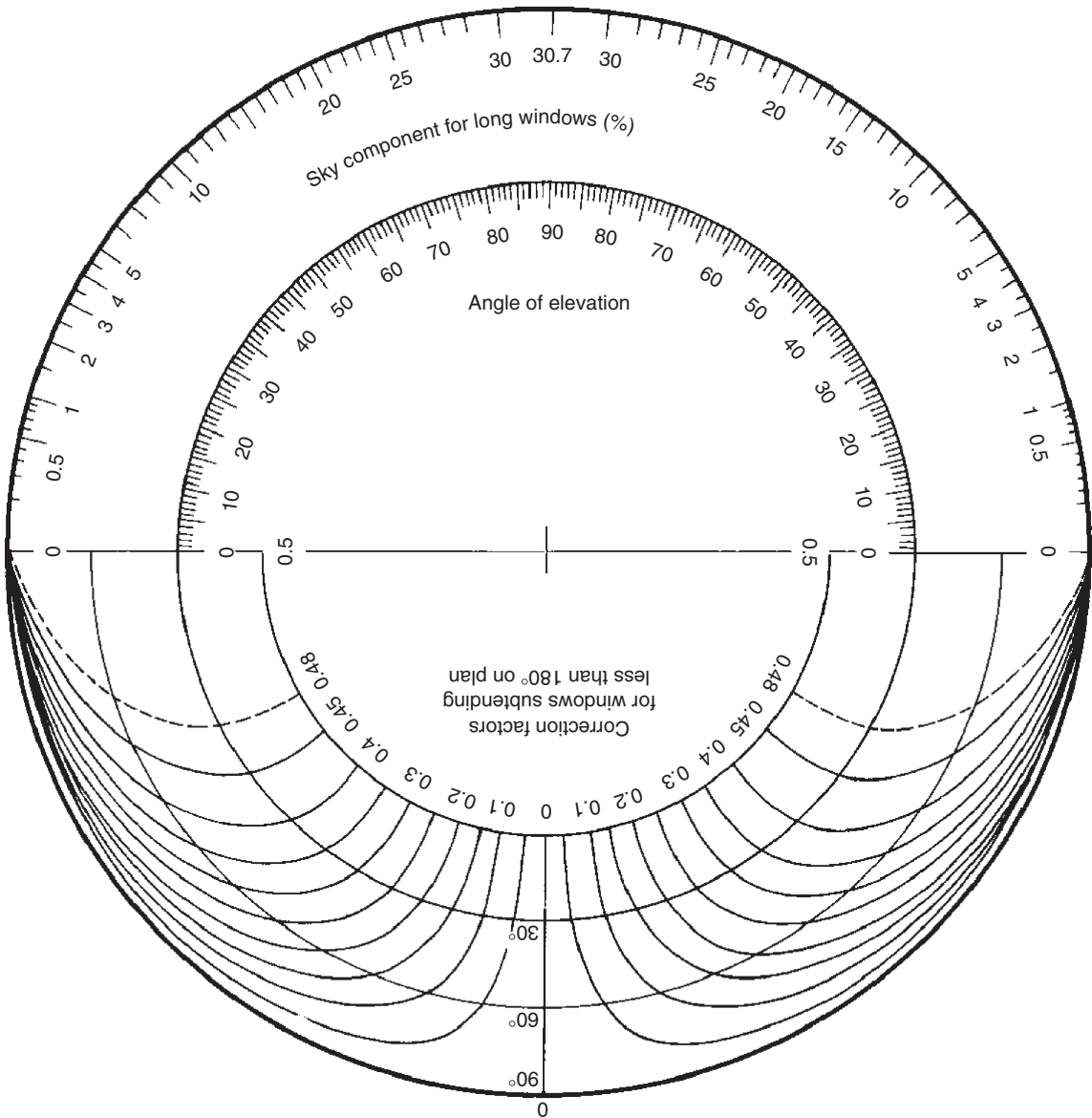
These correction factors are applicable to both the total flux method and the BRS split-flux method of daylight prediction. With the latter these should be applied to the sum of the three components (SC + ERC + IRC)

	Slope	Room use	
		Clean	Dirty
<b>M</b>			
<i>Maintenance factors</i>			
Location			
Non-industrial area	Vertical	0.9	0.8
	Sloping	0.8	0.7
	Horizontal	0.7	0.6
Dirty industrial area	Vertical	0.8	0.7
	Sloping	0.7	0.6
	Horizontal	0.6	0.5
<b>G</b>			
<i>Glass factors</i>			
Clear drawn, plate or float glass		1.00	
Polished wired plate glass		0.95	
Wired cast glass		0.90	
Rough cast or rolled glass		0.95	
Cathedral glass		1.00	
Figured glasses		0.80–0.95	
Arctic or reeded		0.95	
Small morocco		0.90	
6 mm 'antisun'		0.85	
6 mm 'calorex'		0.55	
Clear double glazing		0.85	
Transparent plastic sheets		0.65–0.90	
<b>B</b>			
<i>Bars or framing factors</i>			
Generally		$B = \frac{\text{Net glass area}}{\text{Overall window area}}$	
In the absence of precise information:			
All metal windows		0.80–0.85	
Metal windows in wood frames		0.75	
Wood windows and frames		0.65–0.70	

# DATA SHEET D.2.3

## BRS DAYLIGHT FACTOR PROTRACTOR NO. 2

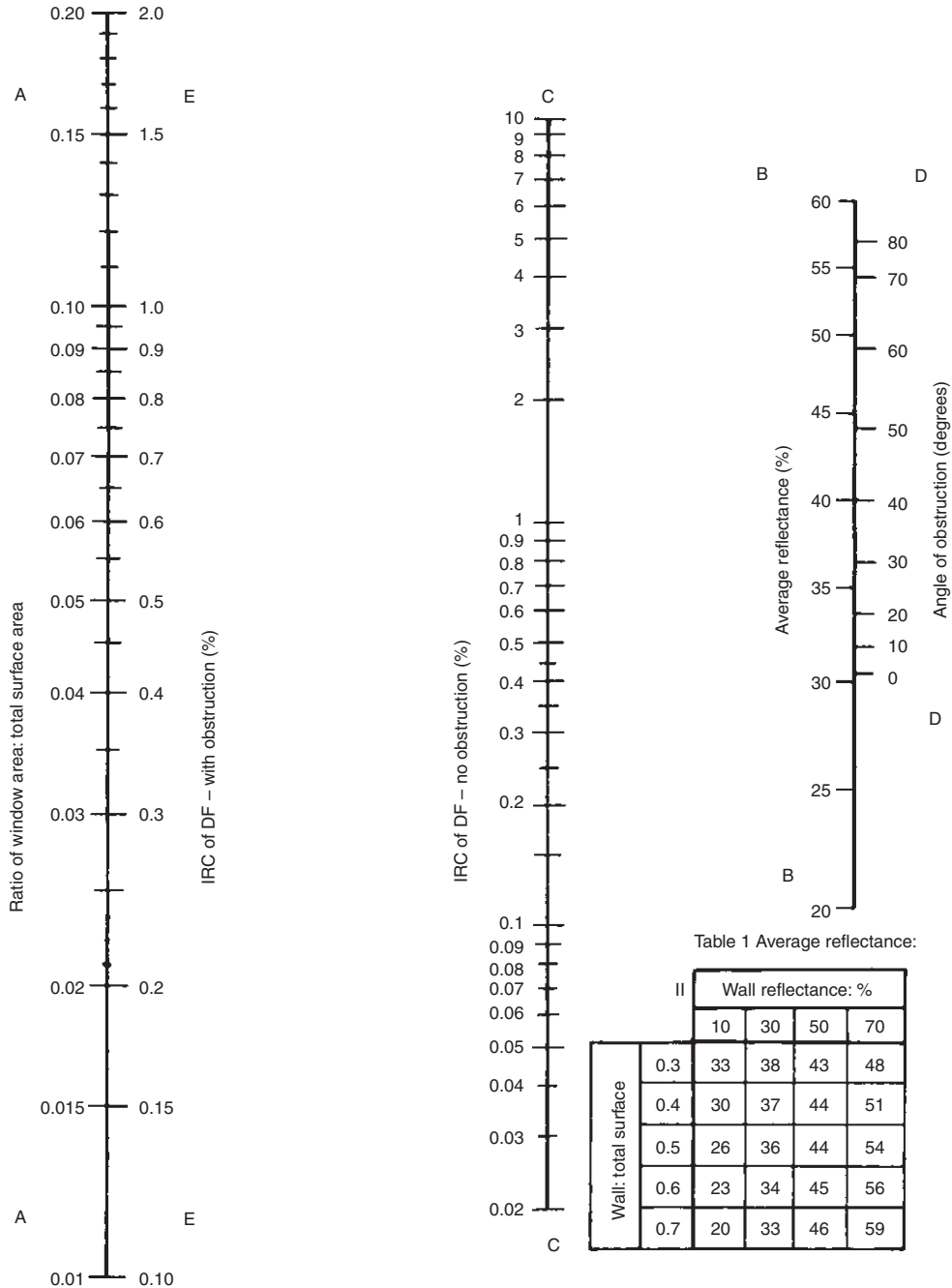
For vertical windows, CIE overcast sky



For use with section and plan of room and window  
As described in Section 2.4.2, and Figs 2.24 and 2.25.

# DATA SHEET D.2.4

## THE INTERNALLY REFLECTED COMPONENT (IRC) NOMOGRAM FOR DAYLIGHT FACTOR



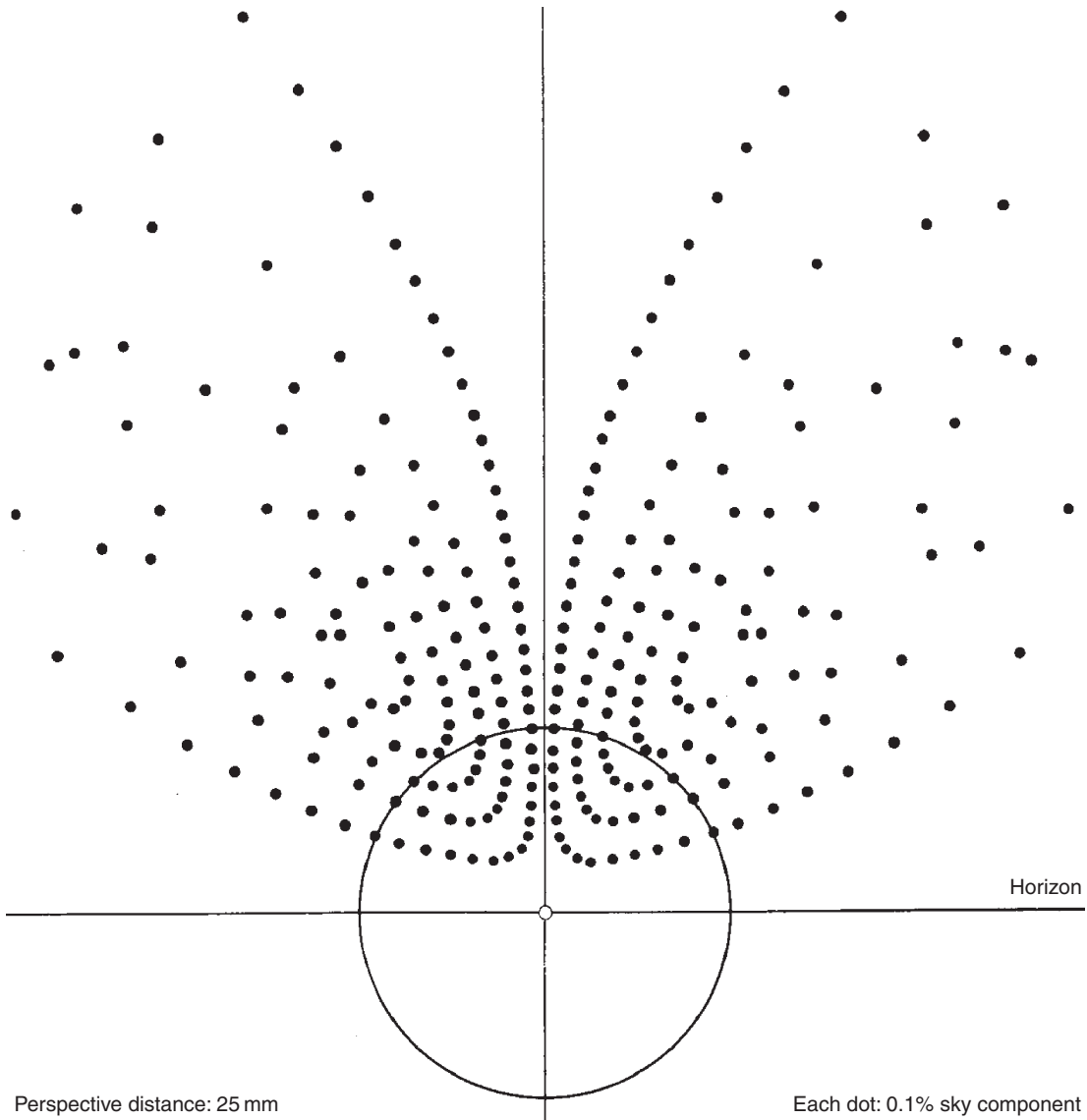
Use of the nomogram is explained in Section 2.4.2 and Fig. 2.26.

**Table 2** D-factors for deterioration of surfaces

Location	Room use	
	Clean	Dirty
Clean	0.9	0.7
Dirty	0.8	0.6

## DATA SHEET D.2.5

### THE PEPPER-POT DIAGRAM FOR DAYLIGHT FACTOR



For use with internal perspective of a window, drawn to a perspective distance of 25 mm as per method sheet M.2.2.

The 25 mm radius circle indicates a cone of vision of  $45^\circ$  all around (a cone with the height of 25 mm, which is the perspective distance, and the base circle is shown)

**DATA SHEET D.2.6****RECOMMENDED ILLUMINANCE and LIMITING GLARE INDEX VALUES**

Visual task	Illuminance (lx)	Glare index
Casual viewing	100	
Cloak room, locker, lavatory, bathroom, auditoria, foyer		No limit
Boiler or furnace room, bulk store		28
Corridor, escalator, stairs		22
Hospital ward		13
Art gallery (general lighting)		10
Rough task, large detail	200	
Store, rough workshop		25
Lift, kitchen, dining room		22
Pharmacy, library, casual reading		19
Lecture room, surgery, telephone exchange		16
Ordinary task, medium detail	400	
Reception areas, food shop		22
General office, keyboard work, control panels		19
Drawing office, dispensary, laboratory, reading		16
Fairly severe task, small detail	750	
Mechanical workshop, fine woodwork, painting, inspection		22
Computer room, dressmaking		19
Needlework, art room		16
Severe prolonged task, small detail	900	
Supermarket display		25
Electronic or fine mechanical assembly veneer work		22
Instrument factory, fine painting, colour inspection		19
Jewel or watch factory, proof reading		16
Very severe prolonged task, very small detail	up to 2000	
Sorting, grading of leather, cloths, hand-tailoring, engraving		19
Precision instrument or electronics assembly		16
Gem cutting, gauging very small parts		10
Exceptional task, minute detail	3000	
Minute instrument work using optical aids		10

These are fairly general recommendations compiled from many sources. The Australian Standard AS1680, as well as the IES Code for Interior Lighting give extensive tables for general lighting and various industrial processes as well as for public and educational buildings.



# DATA SHEET D.2.7

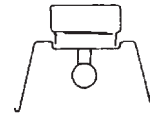
## UTILISATION FACTORS OF TYPICAL LUMINAIRES

Room index	Reflectance of ceiling and walls										
	C:	0.7					0.5				
	W:	0.5	0.3	0.1	0.5	0.3	0.1	0.5	0.3	0.1	
0.6	0.29	0.24	0.19	0.27	0.22	0.19	0.24	0.21	0.19		
0.8	0.37	0.31	0.27	0.35	0.30	0.25	0.31	0.28	0.24		
1.0	0.44	0.37	0.33	0.40	0.35	0.31	0.35	0.32	0.29		
1.25	0.49	0.42	0.38	0.45	0.40	0.36	0.39	0.36	0.33		
1.5	0.54	0.47	0.42	0.50	0.44	0.40	0.43	0.40	0.37		
2.0	0.60	0.52	0.49	0.54	0.49	0.45	0.48	0.44	0.41		
2.5	0.64	0.57	0.53	0.57	0.53	0.49	0.52	0.48	0.45		
3.0	0.67	0.61	0.57	0.60	0.57	0.53	0.56	0.52	0.49		
4.0	0.71	0.66	0.62	0.64	0.61	0.57	0.59	0.55	0.52		
5.0	0.74	0.70	0.66	0.68	0.64	0.61	0.62	0.58	0.54		
0.6	0.36	0.31	0.28	0.35	0.31	0.28	0.35	0.31	0.28		
0.8	0.45	0.40	0.37	0.44	0.40	0.37	0.44	0.40	0.37		
1.0	0.49	0.45	0.40	0.49	0.44	0.40	0.48	0.43	0.40		
1.25	0.55	0.49	0.46	0.53	0.49	0.45	0.52	0.48	0.45		
1.5	0.58	0.54	0.49	0.57	0.53	0.49	0.55	0.52	0.49		
2.0	0.64	0.59	0.55	0.61	0.58	0.55	0.60	0.56	0.54		
2.5	0.68	0.63	0.60	0.65	0.62	0.59	0.64	0.61	0.58		
3.0	0.70	0.65	0.62	0.67	0.64	0.61	0.65	0.63	0.61		
4.0	0.73	0.70	0.67	0.70	0.67	0.65	0.67	0.66	0.64		
5.0	0.75	0.72	0.69	0.73	0.70	0.67	0.70	0.68	0.67		
0.6	0.27	0.21	0.18	0.24	0.20	0.18	0.22	0.19	0.17		
0.8	0.34	0.29	0.26	0.32	0.28	0.25	0.29	0.26	0.24		
1.0	0.40	0.35	0.31	0.37	0.33	0.30	0.33	0.30	0.28		
1.25	0.44	0.39	0.35	0.40	0.36	0.33	0.36	0.33	0.31		
1.5	0.47	0.42	0.38	0.43	0.39	0.36	0.38	0.35	0.33		
2.0	0.52	0.47	0.44	0.47	0.44	0.41	0.41	0.39	0.37		
2.5	0.55	0.51	0.48	0.50	0.47	0.44	0.44	0.42	0.40		
3.0	0.58	0.54	0.51	0.52	0.49	0.47	0.47	0.45	0.43		
4.0	0.61	0.57	0.54	0.55	0.52	0.50	0.49	0.47	0.45		
5.0	0.63	0.59	0.57	0.57	0.55	0.53	0.51	0.49	0.47		
0.6	0.21	0.18	0.16	0.21	0.18	0.16	0.20	0.18	0.16		
0.8	0.28	0.24	0.22	0.27	0.24	0.22	0.26	0.24	0.22		
1.0	0.32	0.29	0.26	0.31	0.28	0.26	0.30	0.28	0.26		
1.25	0.35	0.32	0.29	0.34	0.31	0.29	0.32	0.30	0.28		
1.5	0.37	0.34	0.31	0.36	0.33	0.31	0.34	0.32	0.30		
2.0	0.41	0.37	0.35	0.39	0.37	0.34	0.38	0.36	0.34		
2.5	0.43	0.40	0.38	0.42	0.39	0.37	0.40	0.38	0.37		
3.0	0.45	0.42	0.40	0.44	0.41	0.40	0.42	0.40	0.39		
4.0	0.47	0.44	0.43	0.46	0.44	0.42	0.44	0.42	0.41		
5.0	0.49	0.46	0.45	0.47	0.46	0.44	0.46	0.44	0.43		

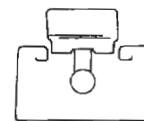
Bare lamp on ceiling or batten fitting  
DLOR = 65%



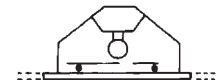
Enamelled reflector or open through  
DLOR = 75%



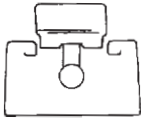
Enclosed plastic diffuser  
DLOR = 50%



Recessed modular diffuser or shallow ceiling mounted diffusing panel  
DLOR = 50%



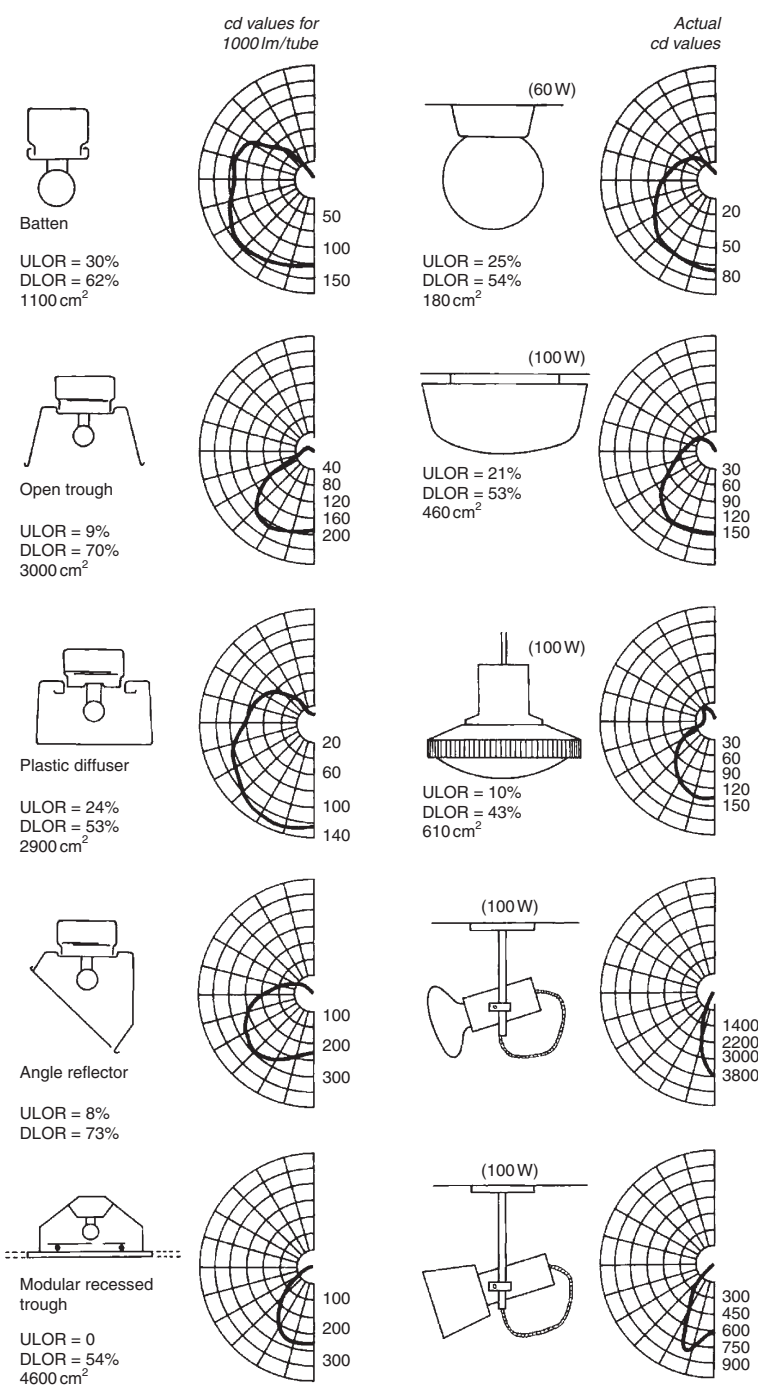
Enclosed opal diffuser  
DLOR = 45%



Room index	Reflectance of ceiling and walls									
	C:	0.7			0.5			0.3		
	W:	0.5	0.3	0.1	0.5	0.3	0.1	0.5	0.3	0.1
0.6	0.23	0.18	0.14	0.20	0.16	0.12	0.17	0.14	0.11	
0.8	0.30	0.24	0.20	0.27	0.22	0.18	0.22	0.19	0.16	
1.0	0.36	0.29	0.25	0.31	0.26	0.22	0.26	0.23	0.19	
1.25	0.41	0.34	0.29	0.35	0.30	0.26	0.29	0.26	0.22	
1.5	0.45	0.39	0.33	0.39	0.34	0.30	0.31	0.28	0.25	
2.0	0.50	0.45	0.40	0.43	0.38	0.34	0.34	0.32	0.29	
2.5	0.54	0.49	0.44	0.46	0.42	0.38	0.37	0.35	0.32	
3.0	0.57	0.52	0.48	0.49	0.45	0.42	0.40	0.38	0.34	
4.0	0.60	0.56	0.52	0.52	0.48	0.46	0.43	0.41	0.37	
5.0	0.63	0.60	0.56	0.54	0.51	0.49	0.45	0.43	0.40	

# DATA SHEET D.2.8

## LUMINAIRE CHARACTERISTICS: POLAR CURVES



**DATA SHEET D.2.9****LAMP CHARACTERISTICS**

Lamp type	Wattage (W)	Ballast	Lumen output
Incandescent (at 240 V)			
Pear shaped	25	—	200
	40	—	325
	60	—	575
	100	—	1 160
	150	—	1 960
	200	—	2 720
	500	—	7 700
Mushroom shaped	40	—	380
	60	—	640
	100	—	1 220
Sodium <sup>#</sup>			
SOX (low pressure)	35	20	4 200
	55	20	7 500
	90	25	12 500
SON (high pressure)	70	25	5 300
	250	30	24 000
Mercury <sup>#</sup>			
MB	80	15	2 700
MBI (metal halide)	400	50	24 000
MBF (mercury fluorescent)	50	15	1 800
	80	20	3 350
MBT (mercury/tungsten)	100	—	1 250
Fluorescent ('white') (in m)			
0.6	20	5	1 050
0.6	40	8	1 550
1.2	40	10	2 800
1.5	50	20	3 100
1.5	65	15	4 400
1.5	80	15	4 850

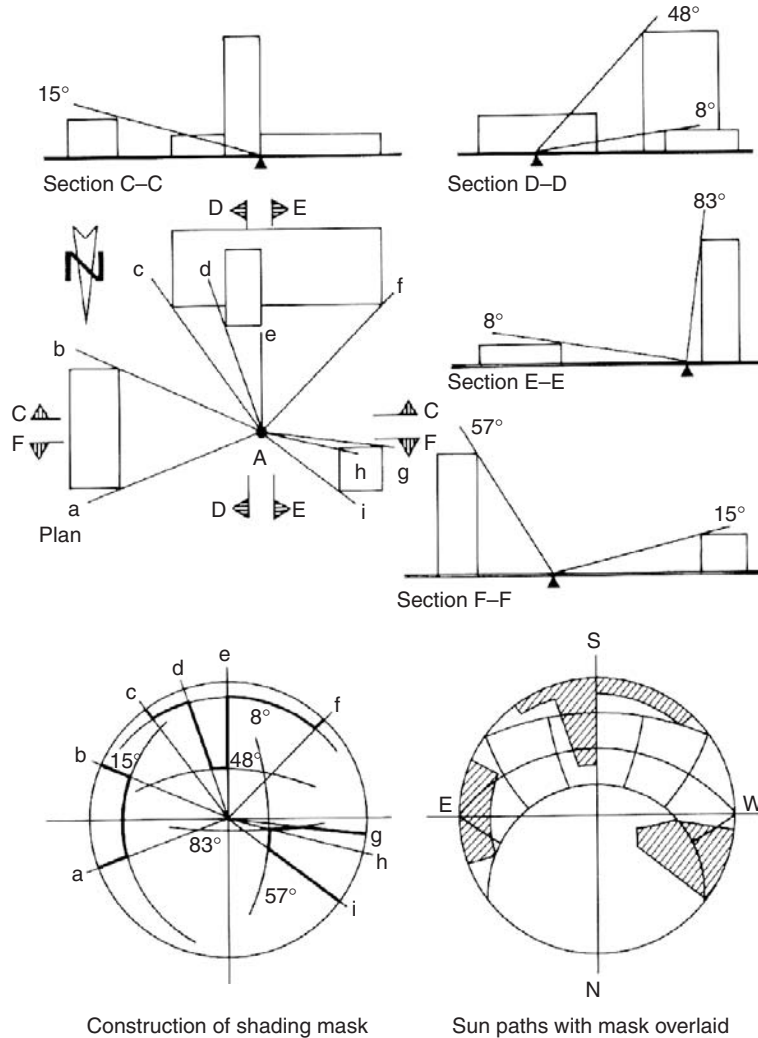
<sup>#</sup>The smallest lamps in each type are shown. The upper limit is around 200 000 lm.

## Corrections to the output of fluorescent lamps

Lamp type	Correction	Lumen output of 1200 mm 40 W
White	1.00	2800
Warm white	0.96	2700
Daylight	0.95	2660
Natural	0.75	2100
Warmtone	0.70	1960
De luxe warm white	0.67	1950
Colour 32 and 34	0.65	1820
Colour matching	0.65	1820
Kolor-rite	0.65	1800
De luxe natural	0.55	1500
Softone 27	0.55	1500
Trucolor 37	0.55	1500
Artificial daylight	0.40	1120

# METHOD SHEET M.2.1

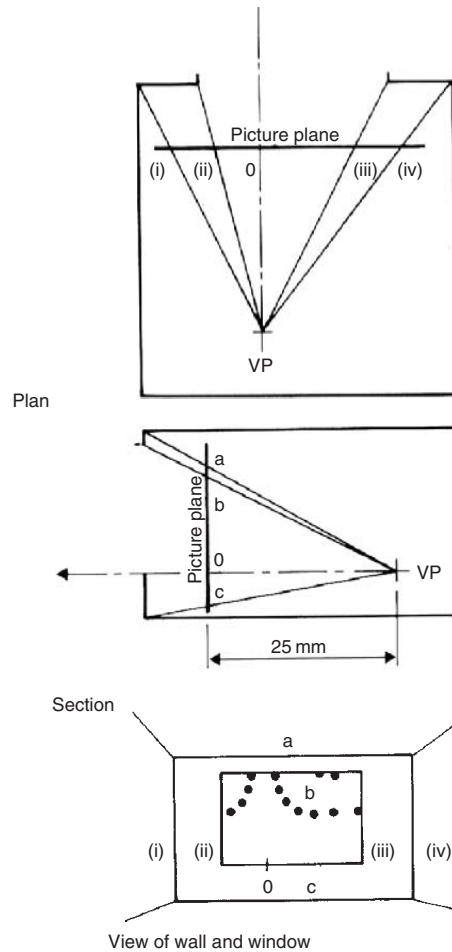
## OVERSHADOWING: A SITE SURVEY



Point A is surrounded by three buildings. On plan draw radial lines to each corner of each building (a to i) and transfer these on the diagram below. From section C-C the top of the east building gives an altitude of 15°. With the protractor facing east, trace the 15° arc from a to b. Section D-D shows that the south building give 48° altitude between d and e and 8° for the low block (c to f). Trace the respective arcs with the protractor facing south. Section E-E confirms the 8° altitude for corner f and give 83° for corner h. Draw the 83° arc between g and h. Section F-F gives 57° for corner h, draw the 57° arc between h and i.

## METHOD SHEET M.2.2

### CONSTRUCTION OF INTERNAL PERSPECTIVE (FOR PEPPER-POT DIAGRAM)



The distance between the point considered (the view-point, VP) and the picture plane must be 25 mm, irrespective of the scale of plan and section, whether the picture plane falls inside or outside (for a VP nearer to the window, the picture plane will be outside).

Mark the width points (i–iv) on the plan of the picture plane, as well as the O point. Mark the height points (a–c) on the section, as well as the O point. Transfer this onto the perspective, left and right, up and down from the O point.

This is a one-point perspective, and the O point is also the vanishing point.

## METHOD SHEET M.2.3

### GLARE INDEX CALCULATION

The glare constant is  $g = \frac{L_1^{1.6} * \omega^{0.8}}{L_2 * p^{1.6}}$ .

$L_1$ , the luminance of the glare source can be found as the source intensity (from the viewing direction) divided by the apparent area of the source.

E.g. we have a 40W bare fluorescent lamp at a horizontal distance of 4.6 m from the observer and 1.4 m above eye level. The actual distance is  $d = 4.8$  m. From D.2.7 the projected area of this lamp is  $1100 \text{ cm}^2$ , i.e.  $0.11 \text{ m}^2$  thus the visual angle (solid angle) subtended by the lamp is  $\omega = \text{area}/d^2 = 0.11/4.8^2 = 0.0048 \text{ sr}$ .

The vertical displacement angle is  $\theta = \arctan(1.4/4.6) = 17^\circ$ , i.e. with respect to the vertical axis of the luminaire, the viewing direction is  $73^\circ$ . The polar curve in D.2.7 gives a source intensity for this direction of 125 cd for 1000 lamp lumens.

For a 40W warm white lamp, D.2.9 gives a lumen output of 2700 lm, thus the actual source intensity is  $I = 125 * 2700/1000 = 337.5 \text{ cd}$  and the source luminance will be

$$L_1 = 337.5/0.11 = 3068 \text{ cd/m}^2.$$

$L_2$ , the background luminance can be estimated from the average reflectance and average illuminance of the field of view. E.g. if surfaces are about Munsell value 4, then (from Eq. 2.2)  $\rho = 4 * 3 / 100 = 0.12$ , and if the illuminance is  $E = 400 \text{ lx}$ , then the luminance will be  $L_2 = 400 * 0.12 = 48 \text{ asb}$  or  $48/\pi = 15.2 \text{ cd/m}^2$ . If the lamp is directly in the line of vision ( $\phi = 0$ ), with the vertical displacement angle of  $17^\circ$ , the position index (from the table below) is 0.67.

$$\text{Thus, } g = \frac{3068^{1.6} \times 0.0047^{0.8}}{15.2 \times 0.67^{1.6}} = 661.$$

If there were several luminaires/lamps in the field of view, the glare constant ( $g$ ) of each should be found and summarised.

The glare index will be  $GI = 10 * \log_{10}(0.478 * \Sigma)$ .

In this case,  $GI = 10 * \log(0.478 * 661) = 25$ .

In terms of the limiting values given in Section 2.5.5 (or in D.2.6), this is acceptable for an industrial situation, but not for an office.

Vertical displacement angles ( $\theta$ , deg.)	Horizontal displacement angle ( $\phi$ , deg.)																
	0	6	10	17	22	27	31	35	39	42	45	50	54	58	61	68	72
62	—	—	—	—	—	—	—	—	—	0.02	0.02	0.02	0.02	0.02	0.02	0.02	0.02
61	—	—	—	—	0.02	0.02	0.02	0.02	0.02	0.02	0.02	0.02	0.02	0.02	0.02	0.02	0.02
58	0.03	0.03	0.03	0.03	0.03	0.03	0.03	0.03	0.03	0.03	0.03	0.03	0.03	0.03	0.03	0.03	0.03
54	0.04	0.04	0.04	0.04	0.04	0.04	0.04	0.04	0.04	0.04	0.04	0.04	0.04	0.04	0.04	0.04	0.03
50	0.05	0.05	0.06	0.06	0.06	0.06	0.06	0.06	0.06	0.06	0.06	0.05	0.05	0.05	0.05	0.04	0.04
45	0.08	0.09	0.09	0.10	0.10	0.10	0.10	0.09	0.09	0.09	0.08	0.08	0.07	0.06	0.06	0.05	0.05
42	0.11	0.11	0.12	0.13	0.13	0.12	0.12	0.12	0.12	0.11	0.10	0.09	0.08	0.07	0.07	0.06	0.05
39	0.14	0.15	0.16	0.16	0.16	0.16	0.15	0.15	0.14	0.13	0.12	0.11	0.09	0.08	0.08	0.6	0.06
35	0.19	0.20	0.22	0.21	0.21	0.21	0.20	0.18	0.17	0.16	0.14	0.12	0.11	0.10	0.09	0.07	0.07
31	0.25	0.27	0.30	0.29	0.28	0.26	0.24	0.22	0.21	0.19	0.18	0.15	0.13	0.11	0.10	0.09	0.08
27	0.35	0.37	0.39	0.38	0.36	0.34	0.31	0.28	0.25	0.23	0.21	0.18	0.15	0.14	0.12	0.10	0.09
22	0.48	0.53	0.53	0.51	0.49	0.44	0.39	0.35	0.31	0.28	0.25	0.21	0.18	0.16	0.14	0.11	0.10
17	0.67	0.73	0.73	0.69	0.64	0.57	0.49	0.44	0.38	0.34	0.31	0.25	0.21	0.19	0.16	0.13	0.12
11	0.95	1.02	0.98	0.88	0.80	0.72	0.63	0.57	0.49	0.42	0.37	0.30	0.25	0.22	0.19	0.15	0.14
6	1.30	1.36	1.24	1.12	1.01	0.88	0.79	0.68	0.62	0.53	0.46	0.37	0.31	0.26	0.23	0.17	0.16
0	1.87	1.73	1.56	1.36	1.20	1.06	0.93	0.80	0.72	0.64	0.57	0.46	0.38	0.33	0.28	0.20	0.17





**DATA SHEET D.3.1****NOISE RATING (NR) AND SPEECH INTERFERENCE LEVEL (SIL) LIMITS**

Room usage	Max NR
Broadcasting and recording studios	15
Concert halls	15
Theatres, intimate	20
Theatres, large	25
Music rooms	20–25
TV studios	20–25
Churches	25
Law courts	25
Lecture theatres without amplification	25
Cinemas	25
Classrooms	30
Hospital wards or operating theatres	30
Hospital day rooms or treatment rooms	35
Restaurants, intimate	35
Restaurants, large	45
Shops, sophisticated	35
Department stores	40
Supermarkets	45
Shops, general	50
Banks	50
Offices	
Executive	20
Conference room (max. 50 persons)	25
Private offices	30
Reception rooms	30
Conference room (max. 15 persons)	35
General office	40–45
Keyboard operators, printers	50–55
Dwellings	25–35
Living area	30
Bedrooms	25
Hotels	
Preferable	25
Acceptable	35

**Speech interference level limits**

Listening distance (m)	Max. SIL (dB)
0.2	69
0.4	63
0.6	59
1.0	54
2.0	48
3.0	45
4.0	42
Adjustments (in dB)	
For female voice	–5
For raised voice	+6
For very loud voice	+12
For shouting	+18

**DATA SHEET D.3.2****ATTENUATION BY GROUND COVER AND MOLECULAR ABSORPTION IN AIR**

Attenuation in dB per 100 m distance

Ground cover	125 Hz	250 Hz	500 Hz	1000 Hz	2000 Hz	4000 Hz
Thin grass, 0.1–0.2 m	0.5	0.5	1	3	3	3
Thick grass, 0.4–0.5 m	0.5	0.5	0.5	12	14	15
Evergreen trees	7	11	14	17	19	20
Deciduous trees	2	4	6	9	12	16

Absorption in air in dB per 100 m distance

Climatic conditions	1000 Hz	2000 Hz	4000 Hz	8000 Hz
<b>21°C</b>				
40% RH	0.3	1.3	3.3	13
60% RH	0.3	0.6	1.6	8
80% RH	0.3	0.6	1.6	5
<b>2°C</b>				
40% RH	1	3.3	5	8
60% RH	0.6	1.6	5	13
80% RH	0	0.3	3.3	8

## DATA SHEET D.3.3

### TRANSMISSION LOSS (dB) OF SOME CONSTRUCTIONS

Construction	Average	Octave-centre frequencies (Hz)					
		125	250	500	1000	2000	4000
<i>Walls</i>							
110 mm brick, plastered	45	34	36	41	51	58	62
150 mm concrete	47	29	39	45	52	60	67
220 mm brick, plastered	50	41	45	48	56	58	62
330 mm brick, plastered	52	44	43	49	57	63	65
130 mm hollow concrete blocks	46	36	37	44	51	55	62
75 mm studs, 12 mm plaster boards	40	26	33	39	46	50	50
75 mm studs, 6 mm ply both sides	24	16	18	26	28	37	33
Do. but staggered separate studs and ply	26	14	20	28	33	40	30
<i>Floors</i>							
T&G boarding, plasterboard ceiling	34	18	25	37	39	45	45
Do. but boards floating on glass wool	42	25	33	38	45	56	61
Do. but 75 mm rock wool on ceiling	39	29	34	39	41	50	50
As 10 + 75 mm rock wool on ceiling	43	27	35	44	48	56	61
As 10 + 50 mm sand pugging	49	36	42	47	52	60	64
125 mm reinforced concrete slab	45	35	36	41	49	58	64
As 14 + floating screed	50	38	43	48	54	61	65
150 hollow pot slab + T&G boards	43	36	38	39	47	54	55
<i>Windows</i>							
Single-glazed, normal	22	17	21	25	26	23	26
Double 4 mm glass, 200 absorb. reveals	39	30	35	43	46	47	37
Do. but 10 mm glass panes	44	31	38	43	49	53	63
<i>Partitions</i>							
Two sheets 10 mm ply, 38 mm cavity		20	25	23	43	47	
Do. +10 kg/m <sup>2</sup> lead on inside faces		25	31	38	57	62	
Do. but also fibreglass absorber in cavity		29	42	49	59	63	
Studs, 10 mm plasterboard both sides		16	35	38	48	52	37
Do. +13 mm fibreglass under plasterboard		22	39	46	56	61	50
Do. but staggered independent frames		34	40	53	59	57	58
75 mm studs, 2 × (5 mm hardboard)		12	21	25	40	46	48
Do. but 2 × (13 mm softboard)		15	25	37	51	51	51
100 mm studs, 2 × (5 mm hardboard)		9	19	28	39	51	60
Do. but 2 × (6 mm hardboard)		13	30	32	38	41	44
200 mm hollow concrete blocks		35	35	40	47	54	60
100 mm precast concrete panel		36	39	45	51	57	65
110 mm brick, 2 × (12 render, 50 × 12 battens, 12 softboard with bonded 6 mm hardboard)		35	43	54	65	73	80
<i>Doors</i>							
50 mm solid timber, normally hung	18	12	15	20	22	176	24
Do. but airtight gaskets	22	15	18	21	26	25	28
50 mm hollow core, normally hung	15						
Do. but airtight gaskets	20						
Double 50 mm solid timber, airtight gaskets, absorbent space (lobby)	45						
<i>Sheets</i>							
50 mm glass wool slab (26 kg/m <sup>2</sup> )	30	27	23	27	34	39	41
Corrugated fibrous cement (34 kg/m <sup>2</sup> )	34	33	31	33	33	42	39
25 mm plasterboard (2 × 12.5 laminated)	30	24	29	31	32	30	34
50 mm plasterboard (4 × 12.5 laminated)	37	28	32	34	40	38	49

**DATA SHEET D.3.4****ABSORPTION COEFFICIENTS: MATERIALS AND COMPONENTS**

Material	Octave-centre frequency (Hz)		
	125	500	2000
<i>Building materials</i>			
Boarded underside of pitched roof	0.15	0.1	0.1
Boarding on 20 mm battens on solid wall	0.3	0.1	0.1
Exposed brickwork	0.05	0.02	0.05
Clinker concrete exposed	0.2	0.6	0.5
Concrete or tooled stone	0.02	0.02	0.05
Floor: cork, lino, vinyl tiles, wood blocks (parquetry)	0.02	0.05	0.1
25 mm cork tiles on solid backing	0.05	0.2	0.6
13 mm softboard on solid backing	0.05	0.15	0.3
Same but painted	0.05	0.1	0.1
13 mm softboard on 25 mm battens on solid wall	0.3	0.3	0.3
Same but painted	0.3	0.15	0.1
Floor: hard tiles or cement screed	0.03	0.03	0.05
Glass in windows, 4 mm	0.3	0.1	0.05
Same but 6 mm in large panes	0.1	0.04	0.02
Glass or glazed ceramic wall tiles, marble	0.01	0.01	0.02
Plastering on solid backing (gypsum or lime)	0.03	0.02	0.04
Plaster on lath, air space, solid backing	0.3	0.1	0.04
Plaster or plasterboard ceiling, large air space	0.2	0.1	0.04
Plywood or hardboard on battens, solid backing	0.3	0.15	0.1
Same but porous absorbent in air space	0.4	0.15	0.1
Exposed water surface (pools)	0.01	0.01	0.02
Timber boarding on joists or battens	0.15	0.1	0.1
<i>Common absorbers</i>			
25 mm sprayed fibres on solid backing	0.15	0.5	0.7
Carpet, e.g. Axminster, thin pile	0.05	0.1	0.45
Same, medium pile	0.05	0.15	0.45
Same, thick pile	0.1	0.25	0.65
Carpet, heavy, on thick underlay	0.1	0.65	0.65
Curtain, medium fabric, against solid backing	0.05	0.15	0.25
Same but in loose folds	0.05	0.35	0.5
25 mm glass wool on solid backing, open mesh cover	0.15	0.7	0.9
Same with 5% perforated hardboard cover	0.1	0.85	0.35
Same with 10% perforated or 20% slotted cover	0.15	0.75	0.75
50 mm glass wool on solid backing, open mesh cover	0.35	0.9	0.95
Same with 10% perforated or 20% slotted hardboard cover	0.4	0.9	0.75
3 mm hbd, bit felt backing on 50 mm air space on solid wall	0.9	0.25	0.1
Two layers bituminous felt on 250 mm air space, solid backing	0.5	0.2	0.1
25 mm polystyrene slab on 50 mm air space	0.1	0.55	0.1
50 mm polyurethane foam on solid backing	0.25	0.85	0.9
25 mm wood wool slabs on solid backing	0.1	0.4	0.6
Same but on 25 mm battens	0.15	0.6	0.6
Same but plastered, mineral wool in cavity	0.5	0.2	0.1

Material	Octave-centre frequency (Hz)		
	125	500	2000
<i>Proprietary absorbers</i>			
6 mm fibrous cement sheet on battens	0.23	0.5	0.2
Burgess perforated metal tiles, 38 mm glass wool	0.15	0.7	0.8
Caneite, 20 mm softboard tiles on solid wall	0.15	0.45	0.8
Celotex 13 mm perforated tiles on solid wall	0.1	0.4	0.45
Same but on 25 mm battens	0.1	0.45	0.4
Same but 32 mm thick, on 25 mm battens	0.25	0.85	0.55
Echostop perforated plaster tiles, 22 mm mineral wool	0.45	0.8	0.65
Euphone glass wool quilt, 25 mm on 25 mm battens	0.3	0.85	0.85
Same but 38 mm in wire netting	0.5	0.9	0.9

**DATA SHEET D.3.5****ABSORPTION COEFFICIENTS (CONTD) AND Abs OF ROOM CONTENTS**

	Octave-centre frequency (Hz)		
	125	500	2000
<i>Proprietary absorbers</i>			
Fibreglass 25 mm, resin bonded mat on 25 mm battens	0.1	0.55	0.75
Same but 50 mm thick on 50 mm battens	0.2	0.7	0.75
Fibreglass, 25 mm tiles on solid wall	0.1	0.6	0.6
Frenger perforated metal panel 20 mm glass wool	0.2	0.65	0.35
Gypklith 25 mm wood wool tiles on 25 mm battens	0.1	0.6	0.6
Gyproc 10 mm perforated plasterboard on 50 mm battens	0.1	0.4	0.15
Gyproc slotted plaster tiles on 50 mm battens	0.05	0.25	0.15
Same with 25 mm fibreglass backing	0.15	0.8	0.25
Paxfelt fibrous cement, 25 mm on 25 mm battens	0	0.55	0.7
Paxtile, perforated fibrous cement sheet, 13 mm on 50 mm battens	0.2	0.5	0.75
Perfonit, perforated wood fibre tile, 25 mm air space	0.2	0.7	0.75
Semtex 25 mm resin board on 25 mm battens	0.2	0.5	0.3
Stramit 50 mm strawboard on 50 mm battens	0.25	0.35	0.45
Thermacoust wood wool slab, 50 mm on solid wall	0.2	0.8	0.75
Tyrolean Callumix plaster, 13 mm on solid wall	0.05	0.15	0.35
Same, but 20 mm	0.1	0.2	0.45
Unitex, perforated wood fibre tile, 13 mm	0.2	0.6	0.65
Same but 20 mm thick	0.25	0.65	0.8
W Callum muslin covered felt on solid wall	0	0.75	0.7
W Callum perforated metal +75 mm rock wool in calico	0.4	0.2	0.15

Room contents absorption (Abs) in m<sup>2</sup> open window units

	Octave-centre frequency (Hz)		
	125	500	2000
Air (per m <sup>3</sup> )	0	0	0.007
Audience in upholstered seats (per person)	0.186	0.4765	0.51
Audience in wooden or padded seats (per person)	0.158	0.4	9.436
Seat, unoccupied, upholstered	0.121	0.279	0.316
Seat, unoccupied, wooden, padded or canvas	0.075	0.149	0.177
Orchestral player with instrument (average)	0.37	1.07	1.21
<i>Note:</i> The floor absorption should be reduced, if 'shaded' by seats (its effectiveness is reduced), by (%)	20	40	60

## METHOD SHEET M.3.1

### AVERAGING OF TL FOR DIFFERENT WALL AREAS

- 1 A wall of 15 m<sup>2</sup> consists of 14 m<sup>2</sup> of 220 mm brickwork (TL = 50 dB) and a 1 m<sup>2</sup> single-glazed window (TL = 22 dB). What is the average TL?

The TL values must first be converted to transmittances ( $\tau$ ), the area-weighted average transmittance found and converted back to TL.

$$\text{From Eq. 3.8: } \tau = \text{antilog} \frac{-TL}{10}.$$

$$\text{For brick wall: } \tau_b = \text{antilog} \frac{-50}{10} = 0.00001.$$

$$\text{For window: } \tau_w = \text{antilog} \frac{-22}{10} = 0.00631.$$

$$\text{Average } \tau = \frac{14 \times 0.00001 + 1 \times 0.00631}{15} = 0.00043.$$

$$\text{From Eq. 3.7: } TL = 10 \times (-\log \tau)$$

$$TL = 10 \times (3.367) = 33.67 \text{ dB.}$$

The window has a dominant influence, even if it is only 1 m<sup>2</sup>.

- 2 If we have the same wall, but with an unglazed opening of 1 m<sup>2</sup> the result is even more striking:

$$\tau_b = 0.00001, \text{ as above.}$$

$$\tau_o = 1, \text{ by definition.}$$

$$\text{Average } \tau = \frac{14 \times 0.00001 + 1 \times 1}{15} = \frac{1.00014}{15} = 0.06668.$$

$$TL = 10 \times (-\log 0.06668) = 11.76 \text{ dB.}$$

The result is not much better if the opening is only 0.25 m<sup>2</sup>:

$$\text{Average } \tau = \frac{14 \times 0.00001 + 0.25 \times 1}{15} = \frac{0.2514}{15} = 0.01668.$$

$$TL = 10 \times (-\log 0.01668) = 17.78 \text{ dB.}$$

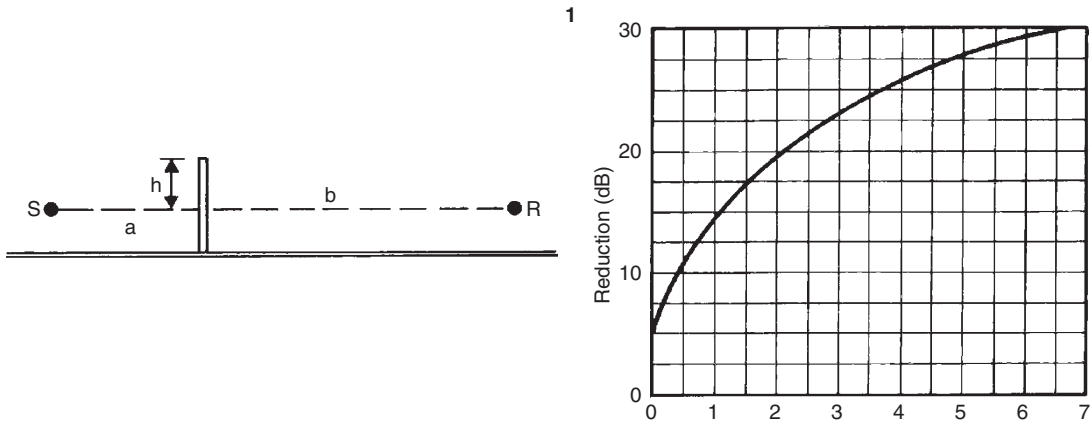
One conclusion that can be drawn from these examples is that if the noise insulation is to be improved, then the component with the least TL should be improved first.



# METHOD SHEET M.3.2

## TRAFFIC NOISE REDUCTION BY A BARRIER

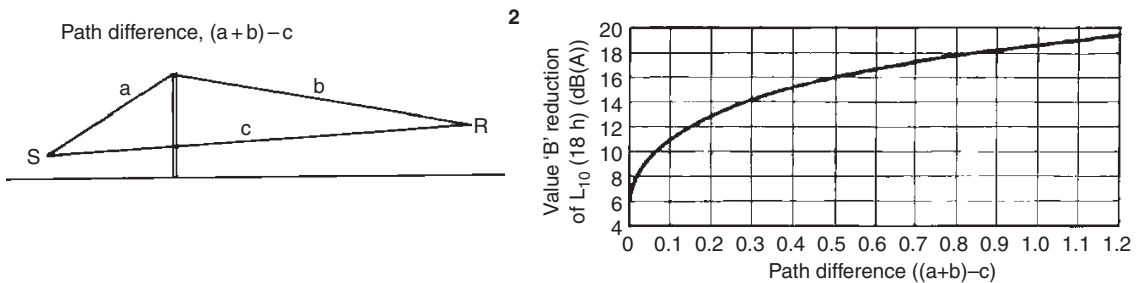
One method of finding the noise reduction effect of a barrier is given in Section 3.3.3. An alternative method uses a 'u' term to find the noise reduction effect.



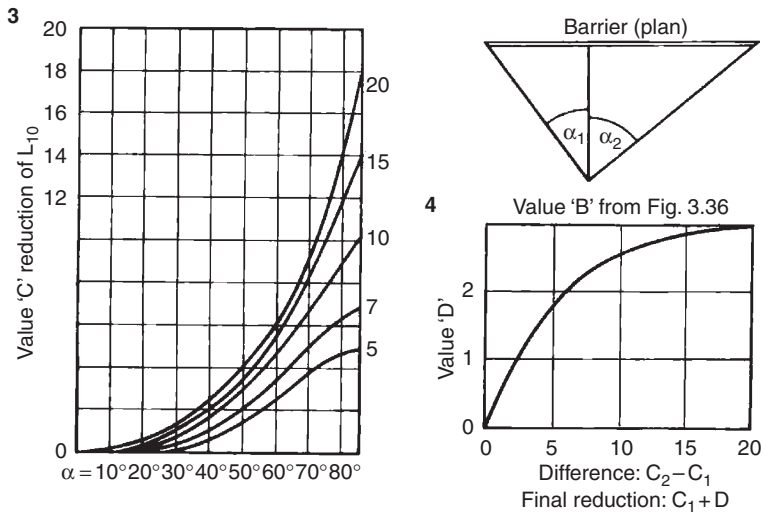
First the value of 'u' must be found from the barrier geometry:

$$u = \frac{1.414 h}{\sqrt{\lambda}} \times \sqrt{\frac{a+b}{a \times b}},$$

then locate this value on the X-axis and read the reduction on the Y-axis. Both these methods are wavelength-specific. A third method is applicable for traffic noise and will give the reduction in dBA of the  $L_{10}(18 - h)$  noise.



First, find the sound path length difference from the barrier geometry, then locate this value on the X-axis and read the traffic noise reduction on the Y-axis. The value found is valid for a very long barrier. For barriers of a finite length, the following correction is applicable.



Find the angle  $\alpha_1$  at the receiver point, from the plan and locate this on the X-axis of Graph 3. Select the curve corresponding to the reduction from an infinite barrier (from above). Read the 'C' value. Repeat for  $\alpha_2$  and get the difference between the two C-values. Locate this on the X-axis of Graph 4. From the curve read the value 'D' on the Y-axis and add this to the larger C-value to get the corrected traffic noise reduction effect in dBA.

## METHOD SHEET M.3.3

### CALCULATION OF REVERBERATION TIME

A simple rectangular lecture room is to be designed to seat 120 people. Fig. 3.41 suggests a volume of 4.5 m<sup>3</sup>/persons, which would give 540 m<sup>3</sup>. A height of 2.7 m is chosen, which gives a floor area of 200 m<sup>2</sup>. For ease of access this is increased to 240 m<sup>2</sup>. Take the floor dimensions as 20 × 12 m. Thus, the volume is 20 × 12 × 2.7 m = 648 m<sup>3</sup>. The desirable RT is suggested by Fig. 3.47 for this room volume as 0.8 s. As the room is used for listening to speech, there is no need to increase the RT at lower frequencies. Inverting Eq. 3.11, the required absorption can be found:

$$\text{Abs} = \frac{0.16 V}{RT} = \frac{0.16 \times 648}{0.8} = 129.6 \text{ m}^2.$$

The total absorption given in the room is calculated in a tabulated format. Absorption coefficients are obtained for D.3.4 and absorption of room contents from D.3.5. Assume that the room is 2/3 occupied.

		125 Hz	Abs	500 Hz	Abs	2000 Hz	Abs
<i>Room contents</i>	80	0.158	12.64	0.4	32	0.436	34.88
Persons on hard seats	40	0.075	3	0.149	5.96	0.177	7.8
Seats unoccupied	648 m <sup>3</sup>	—	—	—	0.007		4.54
<i>Surfaces</i>		a	Abs	a	Abs	a	Abs
Walls, brick, plastered	168 m <sup>2</sup>	0.02	3.36	0.02	3.36	0.04	6.72
Doors	4.8 m <sup>2</sup>	0.3	1.44	0.1	0.48	0.1	0.48
Ceiling, plasterboard	240 m <sup>2</sup>	0.2	48	0.1	24	0.04	9.6
Floor vinyl on concrete	240 m <sup>2</sup>	0.05	12	0.05	12	0.1	24
Less shading by seats		20%	-2.4	40%	-4.8	60%	-14.4
Totals			78.04		73		72.9

As the required absorption for all frequencies is 129.6 m<sup>2</sup>, some improvements are needed, fairly evenly across all frequencies. The rear wall should not be reflective, so it can be lined with an absorbent. Its area is 32.4 m<sup>2</sup>, but it contains the two doors, so the net area is 32.4 - 4.8 = 27.6 m<sup>2</sup>. The second improvement may be to lay carpet on the floor:

Wood wool slabs	27.6 m <sup>2</sup>	0.15		0.6		0.6	
Less original		-0.02		-0.02		-0.04	
		0.13	3.59	0.58	16.01	0.56	15.46
Carpeting	240 m <sup>2</sup>	0.1	24	0.25	60	0.33	80
Less shading by seats		20%	-4.8	40%	-24	60%	-48
Less original			-9.6		-7.2		-9.6
New totals			91.23		117.81		110.76

Both these absorbers introduced are more effective in the high frequencies, so the absorption is now rather unbalanced. Some improvement is

still needed at the higher frequencies, but much more at the 125 Hz band. A part of the ceiling may be replaced by a felt-backed hardboard panel absorber. This may tip the balance the other way, so the final adjustment is made by hanging a curtain over some of the wall, this again being more effective in the high frequencies.

Hardboard panel	50 m <sup>2</sup>	0.9		0.25		0.1	
Less original ceiling		<u>-0.2</u>		<u>-0.10</u>		<u>0.04</u>	
		0.7	35	0.15	7.5	0.06	3
Curtain, loose	32 m <sup>2</sup>	0.05		0.15		0.5	
Less original wall		<u>-0.02</u>		<u>-0.02</u>		<u>0.04</u>	
		0.03		0.13		0.46	14.72
New totals			127.19		129.47		127.48
Check $RT = 0.16V/A = 103.68/A$ :			0.81 s		0.8 s		0.81 s

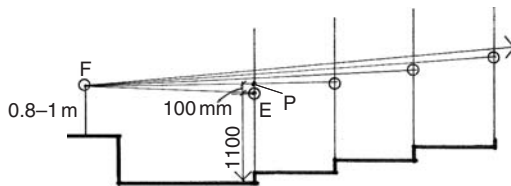
## METHOD SHEET M.3.4

### PROGRESSIVE RAKE AND PRINCIPLES OF OPTICAL ACOUSTICS

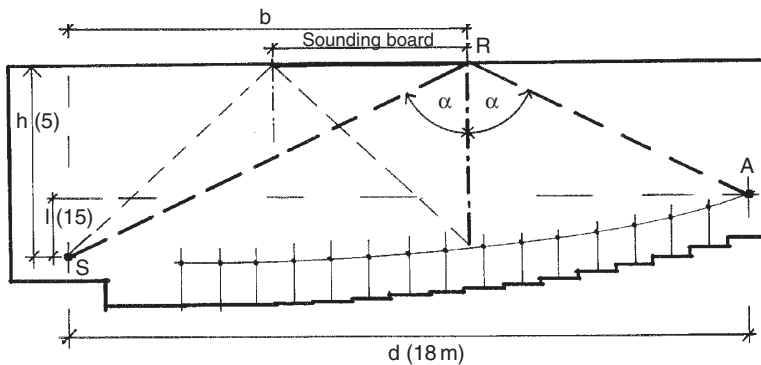
The purpose of raked seating is to ensure uninterrupted sight-lines of the speaker (or e.g. the bottom of a projection screen) for all members of the audience. At the same time, the rake should not be more than necessary.

On a longitudinal section of the auditorium locate the F (focus) point, usually 0.8–1 m above stage level. Locate a vertical line representing the first row of seating and draw such vertical lines at distances corresponding to row spacing, for each row of seats in the auditorium. Mark the notional eye-level (point E) for the front row at 1100 mm above the floor. Mark a point P at 100 mm above E. Draw a line from the F point to this P and extend it to the second row. Its intersection with the vertical will give the second E point. Repeat this for the second to the third row, and for all rows.

This will locate the eye-level for each row, and for each eye level measure 1100 mm down, to determine the floor level for that row.



In an auditorium with a flat floor (where the source and listeners are at about the same level) the setting out of a ceiling reflector is quite easy. E.g. if it is decided that the rear half of the listeners should receive reflected reinforcement from the ceiling, take the distance between the source and the furthest listener, and halve that distance to locate the edge of the sounding board furthest from the stage. Repeat for the mid-point, and the halving of that distance will give the edge of the sounding board nearest to the stage. The horizontal ceiling between the two points should be treated as a sounding board.



With raked seating, there are two possibilities:

- 1 The distance between the source and the rear seating row can be halved to mark the edge of the sounding board. As the 'sound ray' incident on the board and that reflected are not symmetrical, the angle between the two should be halved and the sounding board must be at right angles to this halving line. The sounding board will have to be slightly tilted.
- 2 If the sounding board is to be kept horizontal, then the position of the edge of sounding board furthest from the stage (the reflection point R) can be found as follows:

- the horizontal distance between the speaker (S) and the rear row of the audience (A) is  $d$ ;
- the level difference between A and S is  $L$ ;
- the ceiling height from point S is  $h$ ;
- the horizontal distance between S and R is  $b$ ;
- then  $b$  can be determined: we have two triangles, where the angle of incidence and angle of reflection at the point R must be the same, say  $\alpha$ , then,

$$\tan(\alpha) = b/h = (d - b)/(h - L)$$

$d$ ,  $h$  and  $L$  are known; say  $d = 18$  m,  $h = 5$  m and  $L = 1.5$  m, then  $b$  is to be determined.

$b/5 = (18 - b)/(5 - 1.5)$ , from which  $3.5b = 5(18 - b) = 90 - 5b$   
 $8.5b = 90$ , thus  $b = 90/8.5 = 10.6$  m

- repeat the same for the edge of sounding board nearest to the stage.

## METHOD SHEET M.4.1

### 'PRESENT WORTH' AND THE DISCOUNTED CASH-FLOW METHOD

1 The question is which would I prefer: to get \$100 now, or \$150 in 3 years' time? Or in more formal terms: what is the *present worth* of \$150 payable in 3 years? This can be assessed by using the compound interest expression in reverse.

An amount invested at present ( $P$ ) at an annual interest rate ( $i$ ) for a number of years ( $y$ ) will increase to an amount ( $A$ ) equal to the invested amount plus the compound interest earned:

$$A = P + P \times i^y = P + (1 + i)^y \quad (1)$$

from which  $P$  can be expressed as

$$P = A \times (1 + i)^{-y}, \quad (2)$$

where  $P$  is referred to as the present worth of an amount  $A$  payable (or saved) in  $y$  years.

2 If we have a regular annual sum ( $B$ , benefit) saved (or payable) annually, the present worth of this will be

$$P = B \frac{(1 + i)^y - 1}{i(1 + i)^y} = B \frac{1 - (1 - i)^{-y}}{i} \quad (3)$$

the latter part of this expression is referred to as the *present worth factor*

$$F = \frac{1 - (1 - i)^{-y}}{i}. \quad (4)$$

3 If a capital investment ( $C$ ) results in an annual benefit ( $B$ ), then the *simple pay-back period* is the number of years when the accumulated benefits become equal to the investment:

$$C = B \times y, \text{ from which } y \text{ can be expressed as } y = C/B. \quad (5)$$

The pay-back period, if the 'cost of money' is to be allowed for can be found as  $C = B \times F$ , from which  $F = C/B$  and  $F$  is found from Eq. 4. In an inflationary climate, the anticipated annual inflation rate ( $r$ ) must be taken into account. Eq. 4 will become

$$F' = \frac{1}{i - r} \left[ 1 - \left( \frac{1 + r}{1 + i} \right)^y \right], \quad (6)$$

but if inflation will cause the annual benefit,  $B$ , (or operating cost) to also increase, then

$$F'' = \frac{1 + r}{i - r} \left[ 1 - \left( \frac{1 + r}{1 + i} \right)^y \right]. \quad (7)$$

E.g. if  $i = 6\%$ , the increased sum is

$$A = 100 \times (1 + 0.06)^3 = 119.10$$

$$119.1 < 150.$$

The present worth of \$150 is

$$P = 150 \times (1 + 0.06)^{-3} = 125.94$$

$$125.94 > 100$$

Both suggest that the \$150 in 3 years' time is better.

E.g. Is it worth buying a solar water heater?

Cost: \$2300 less \$500 subsidy = \$1800

Annual saving in electricity (say) \$235.

If  $i = 6\%$  and  $r = 2\%$  and we consider a 10-year amortisation period:

$$F'' = \frac{1.02}{0.04} \left[ 1 - \left( \frac{1.02}{1.06} \right)^{10} \right] = 25.5(1 - 0.68) = 8.14,$$

the payback period would be 8.14 years.

The present worth of 10-year savings will be  $P = 235 \times 8.14 = \$1912.90$  as  $1912.90 > 1800$ , it is worth buying.





# APPENDIX 1

## **Declaration of interdependence for a Sustainable Future**

IUA/AIA World Congress of Architects, Chicago, 18–21 June, 1993

### **Recognising that**

- A sustainable society restores, preserves and enhances nature and culture for the benefit of all life, present and future
- A diverse and healthy environment is intrinsically valuable and essential to a healthy society
- Today's society is seriously degrading the environment and is not sustainable
- We are ecologically interdependent with the whole natural environment
- We are socially, culturally and economically interdependent with all of humanity
- Sustainability, in the context of this interdependence requires partnership, equity and balance among all parties
- Buildings and the built environment play a major role in the human impact on the natural environment and on the quality of life
- A sustainable design integrates consideration of resources and energy efficiency, healthy buildings and materials, ecologically and socially sensitive land-use and an aesthetic sensitivity that inspires, affirms and ennobles
- A sustainable design can significantly reduce adverse human impacts on the natural environment, while simultaneously improving quality of life and economic well-being.

### **We commit ourselves**

as members of the world's architectural and building design professions, individually and through our professional organisations to

- Place environmental and social sustainability at the core of our practices and professional responsibilities

- Develop and continually improve practices, procedures, products, curricula, services and standards that will enable the implementation of sustainable design
- Educate our fellow professionals, the building industry, clients, students and the general public about the critical importance and substantial opportunities of sustainable design
- Establish policies, regulations and practices in government and business that ensure sustainable design becomes normal practice
- Bring all existing and future elements of the built environment – in their design, production, use and eventual re-use – up to sustainable design standards.

# APPENDIX 2

## **Environment Policy of the Royal Australian Institute of Architects**

(an abbreviated version)

The architectural profession is committed to environmental and social sustainability. Such a commitment will contribute to preserving and restoring the ecological processes on which life depends, thereby providing the opportunity to maintain or improve the quality of life for current and future generations and maintain the intrinsic values of the natural environment.

The following five specific principles should be adopted in realising this commitment

1. **Maintain and restore biodiversity** by considering the impact of design decisions and materials selection on ecosystems away from the site: by evaluating site and local ecosystems, by recommending against building in areas where development is likely to have significant negative environmental consequences, by maintaining and enhancing the site ecosystems, preserving vegetation and top-soil, restoring habitat corridors, by promoting innovative building and development that will lead to a sustainable society.
2. **Minimise the consumption of resources** by practising land and soil conservation, by recommending building on and rehabilitating already disturbed land, by using “renewable” in preference to finite resources by encouraging the reduction of energy consumption (e.g. by passive thermal controls and improving efficiency), by practising waste management and avoiding disposable elements, by recycling buildings and using recycled components, by using water-cycle management techniques, by developing increased densities in urban and built forms considering alternatives to development, such as the “no development” option, by participating in formulation of the client’s brief to ensure efficiency of the space and services provision, by designing for durability, ensuring adaptability through the concept of “loose fit”, by recommending the use of materials and equipment for longer life, low maintenance and appropriate quality and finish.
3. **Minimise pollution of air, soil and water** by minimising greenhouse gas emissions (e.g. CO<sub>2</sub> and CFCs), by reducing transport requirements and all forms of fossil fuel-based energy use, by increasing CO<sub>2</sub> absorption through vegetation and tree-planting, by avoiding the use of CFCs in refrigeration, as

well as in aerosols and packaging materials and in halon fire extinguishers, by minimising all forms of pollution, erosion, stormwater and effluent run-off, including pollution that may be caused in extraction, processing and manufacture of building materials and components.

4. **Maximise health, safety and comfort** by considering occupational health and safety in extraction, processing and manufacture of components, on the construction site (e.g. noise, noxious solvents) and avoiding the use of poisonous vermin and weed control materials, by designing for good neighbourliness (e.g. glare, noise, solar access, visual privacy), by integrating buildings with the natural environment, avoiding materials with harmful emissions and by the quality of the internal environment.
5. **Raise awareness of environmental issues** among clients, authorities, consultants, organisations, manufacturers, fellow architects and students by assisting in educational processes, developing new solutions, encouraging environmentally sound products and advocating the role of architects in contributing to a sustainable society.

# Index

- A-weighting (of sound) 151, 156
- absolute humidity 12, 70
- absorbent lining 166, 176
- absorbers (sound) 172
- absorptance (absorbed) 11, 38, 104, 171
- absorption (of sound) 162, 171, 176
  - chiller 209, 210, 220
  - coefficient (sound) 171, 181, 304
- acceleration 5
- acclimatisation (adjustments) 17, 20
- acoustic coupling 165, 176
  - laboratories 187
  - quality 181
  - shadow 148, 167, 180
  - system 145
- active systems 207, 209
  - thermal controls 76
- adaptability model 20, 224
- adequacy (of lighting) 106
- adjustable shading device 55
- admittance 48, 49, 252, 254, 281
- aerobic bacteria 232
- aerogenerators 204
- agenda 21 234
- air conditioning 88
  - flow 14, 16
  - handling unit 88
  - load 76
  - movement 17, 28, 51, 59, 60
  - temperature 17
  - tightness 63, 66
- airborne sound 145, 161, 166, 170
- aircraft noise 160
- albedo 73
- all-air system 89
- alternating current 195
- alternating solar gain factor 47, 258
- altitude (solar) 23, 36
- aluminium foil 42, 43
- ampere 195
- amplifier 184
- ammonia 215
- amplitude (heat flow) 46
- anaerobic bacteria (digestion) 206, 232
- angle of incidence (INC) 26, 36
- anidolic ceiling 126
- annoyance threshold 160
- anthropogenic heat 74
- apostilb 102
- aphelion 22
- artificial sky 120, 121
- aspect ratio 64
- assisted resonance system (ARS) 186
- atmosphere 27
- atmospheric depletion 26
- attached greenhouse 56
- attic fan: *see* whole house fan
- audible range 152, 153
- auditory response 150
  - tube 152
- aural acuity 153
  - communication 154
  - perception 152
- auxiliary heater 207, 210
- azimuth (solar) 23
  
- background noise 177
- bacillus coli 229
- balance (acoustics) 182
- balanced flue 220
- balanced system (ventilation) 87
- balancing of load (electrical) 218
- ballast 127
- barriers (noise) 167
- batteries 215
- beam (or direct) component (of radiation) 37
- beam sunlighting 123
- behaviour (of people), -al 123
- behaviour (thermal) 46
- behaviourist school 189
- Bel 149
- biochemical oxygen demand (BOD) 233
- bioclimatic chart 21
  - architecture 189
  - design 51
- biomass 199, 205
- blend (in acoustics) 182
- blinds 65, 259
- block heaters 215, 225
- boreholes 213, 228
- boundary layer 74
- brain 152
- broad-band sound 146, 152
- Brundtland report 234
  
- building conductance 33, 41
  - energy management system (BEMS) 91
  - fabric (as heat storage) 91, 215
  - form and fabric 64
  - mass 58, 68, 92
  - permit 221
  - regulations 222, 223
- bulk insulation *see* resistive insulation
  
- candela 100, 102
- capacitive insulation 45, 48, 65, 66, 67
- capacitor 196
- capital cost 241
- capital energy 236
- carbon dioxide (CO<sub>2</sub>) emissions 202, 218, 240
- carbon – nitrogen (C–N) ratio 206
- cavity (resonant) absorbers 174
  - resistance (heat flow) 42
  - resonance 165
- central heating 81
- chemical energy 195
  - to electrical conversion 200
  - to thermal conversion 199
- Chicago Congress 234
- chiller 89, 209, 210
- choke 132
- chroma 100
- chromaticity chart 98
- circuit breaker 218, 219
- circuit protection 219
- clarity (in acoustics) 180
- Clean Air Act 231
- clear sky 109
- climate 22
  - classification 33
  - graph 29, 32
  - zones 32, 221
- climatic data 29, 73, 123
- clo 18, 21
- clock time *see* local time
- clothing 17, 18
- cloud cover 28
- coal 215
- coastal winds 74
- cochlea 152

- coefficient of performance (CoP) 80  
 coefficient of performance (solar systems) 207  
 cogeneration 202, 217  
 coincidence 163, 164  
 cold climate 32, 33, 51, 66  
 colour appearance 106, 128, 129  
   of light 97  
   rendering 100, 107, 128, 129  
   rendering index 128  
   temperature 99, 128  
   wheel (Munsell) 100  
 column speakers 184  
 combined heat and power (CHP) 217  
 combined heat and power solar system (CHAPS) 212  
 comfort index (-ices) 21  
 comfort zone 21, 22, 51, 278  
 compact fluorescent lamp 132  
 complementary colours 99  
 computer simulation 222  
 concave surfaces 180  
 concentrating collectors 209  
   linear focus 209  
   point-focus (dish) 209  
 condensation 70, 72  
   trough 72  
 condenser window 73  
 conduction (thermal) 7  
   heat gain (or loss) 34, 42, 63  
 conductivity 8, 9, 41, 43, 72, 248  
   correction factors 9  
 conductor (electrical) 195  
 conduits 220  
 cones 104  
 conservatory 56  
 consumer unit 218  
 contrast grading 108  
   sensitivity 105  
 control potential zone (CPZ) 57, 59, 60, 61, 278  
 convection 7, 10  
   coefficient 10  
 convector 79, 84  
 conversion efficiency 79  
   processes 199  
 cooling 14  
   effect (air movement) 41  
 Coriolis force 27  
 corner echo 178  
 correlated colour temperature (CCT) 99  
 cosine law 26, 103, 133  
 cost/benefit analysis 241  
 cost of electricity 201  
 coulomb 195  
 courtyard 68  
 crop drying 209  
 cross-ventilation 59, 60, 69  
 crown silvered lamp 130  
 current 195  
 daylight 108  
   design diagram 115  
   distribution 122  
   factor 115  
   factor protractor 116, 287  
 deaf spots 177, 183  
 decibel (dB) 149, 151  
 deciduous trees 76  
 declination 23  
 decomposers 199  
 decrement factor 46, 47, 48, 252, 254  
 definition (in acoustics) 182  
 degree-days 31, 32, 33  
 degree-hours 32, 274  
 dehumidification 14, 73  
 demand-side management (DSM) 225  
 density 8, 248  
 Darreius rotor 204  
 desiccant 91  
 design sky 115  
   conditions 34  
   temperatures 77  
 dew-point temperature (DPT) 70, 71  
 diffraction (of sound) 148, 167  
 diffuse component (of radiation) 37  
   reflection 104  
 diffusivity 281  
 digital metering 226  
 direct current 195  
   gain system 208  
   ratio 135  
   sound 171  
 directionality (of light) 107  
 directionality (of sound) 157  
 discharge lamps 127  
 discontinuity (structural) 171  
 discontinuous frame (window) 54  
   spectrum 128  
 dish (solar collector) 209  
 district heating schemes 217  
 diversity factor 227  
 domestic hot water (DHW) systems 207, 212  
 downward light output ratio (DLOR) 135, 136  
 dry cell battery 202  
 dry resultant temperature 18  
 Du Bois area 18  
 dual duct system 90  
 ducts, ductwork 88  
 dynamic heat flow 45, 48  
 ear 145  
   drum 152  
 earth 22, 27  
 earth leakage circuit breaker 219  
 earth source heat pump 214  
 earthing 219  
 earth-works 235  
 eaves 67  
 echo 177, 178  
 ecological factor (EF) 237  
 ecology 241  
 economic(-s) 93, 225, 241  
 economy cycle 91  
 effective temperature (ET\*) *see also*  
   standard effective temperature 21  
 efficacy 129  
 efficiency 79, 218, 225  
 effluent 233  
 egg-crate (shading) device 36  
 Einstein 198  
 electric charge 195  
   heaters 79  
   lighting 126  
 electrical energy (electricity) 195, 200, 217  
   installations 218  
 electro-luminescence 127  
 electromagnetic radiation 97  
 electromotive force (EMF) 195  
 elemental method (to show compliance) 223  
 elevated reservoir 215  
 embodied energy 236, 237  
 emittance 11, 250  
 emitter (heat) 82, 209  
 endothermic 195  
 energy 5, 193, 236  
   carrier 218  
   certification (of buildings) 222  
   conservation 224, 225  
   conversion 199, 200  
   crops 205  
   flow rate (flux) 7  
   rating (of buildings) 221, 222, 223, 239  
   sources 196, 225  
   storage 214, 225  
   use 217  
 enthalpy 13  
 envelope conductance 41  
 environmental noise 165  
   rating (of materials) 238, 239  
   standards 224  
   temperature (EnvT) 18  
 equal loudness contours 150, 151  
 equidistant (charts) 24  
 equilibrium (thermal) 17

- equinox 23  
 equivalent sound level 159  
 evaporative cooling (-er) 51, 60, **61**,  
   63, 91  
 evaporative heat loss (Ev) 17, 34  
 exothermic 195  
 expectations (in noise climate) 160  
 expert advice 235  
 externally reflected component (ERC)  
   116  
 extract system (ventilation) 87  
 eye **104**
- fabric (building) 64  
 fans 87  
 fan-coil unit 209  
 Fechner's law 149  
 fence 75  
 fenestration 65  
 fertiliser 233  
 field of vision 137  
 filament 127  
 filters (in light) 99  
 filters (in air conditioning) 88  
 fire reserve (water) 230  
 first law of thermodynamics 6  
 flanking transmission 164  
 flat plate collectors 86, 207, 209  
 flexible sheet (membrane absorber)  
   173  
 floating floor 169, 176  
 floodlight 130  
 floor warming 79, 82  
 flue 81, 220  
 fluorescent coating 128  
   lamps 128, 136  
 flutter-echo 178  
 flux fraction 131  
   installed 135  
   received 135  
 flying saucers 180  
 food chain 199  
 force 5  
 formaldehyde 66  
 fossil fuels 199  
 framing factor 114  
 free-field 147, 157, 161  
 frequency (of sound) 145, 153, 163  
   (of light) 97  
 fresh air (supply) 65, 68  
 fuel cells 200, 202, 215  
 fuel storage 81  
 fullness of tone 180, 182  
 fundamental frequency 146  
 fuse 219
- garbage dumps 233  
 gas heaters 78  
   installations 221  
   mains 220  
 gaseous fuels 217  
   wastes 231  
 general lighting 134  
 general purpose outlet (GPO) 220  
 generating stations 78  
 geometrical acoustics **178**, 179  
 geothermal energy 213  
 Gestalt psychology 50, 188  
 glare **107**, 111, 137  
   constant 138  
   index 108, 138, 291, 298  
 glass 65  
   factor 114  
 global irradiance (G) 37  
 global warming 28  
 globe thermometer 18  
 greenhouse effect 26, **28**, 206  
   gas emissions 207, 227  
   rating 239  
 grey water 231  
 ground cover 161  
   surface 73  
 growth (rate) 205, 212, 214
- Haas effect 185  
 halogen (lamp) 127  
 harmonics 146  
 Hawthorne effect 189  
 heat 5, 193  
   absorbing glass 39, 124  
   engine 211, 213  
   flow 43  
   flow rate (flux) 7  
   flux density 7  
   loss calculation 76  
   production plant 81  
   pump 79, **80**, 214  
   sink 69, 79  
   transfer wheel (rotary heat  
     exchanger) 91  
 heating (process) 14  
   load 76  
   requirement 33, 77  
   systems **76**  
 heliocentric (view) 23  
 heliostat 125, 126  
 Helmholtz resonators 174  
 high level system (of speakers) 184  
 horizontal shading device 35, 55, 67  
 hot water supply 83–86, 212  
 hot-dry climates **34**, 51, 68  
 hot-dry rock (HDR) technology 213  
 hue 100
- humidification 14  
 humidity 12, 17, 28, 29  
 hydrocarbons 79  
 hydro-electricity 200  
 hydrogen generation 200  
 hydrological cycle 199  
 hyperthermia 19  
 hypothermia 19
- ice storage systems 225  
 igloo 66  
 illuminance **102**, 110, 138, 224, 291  
   vector 110, 141  
 impact noise 166  
 incandescent (lamp) 127, 128, 169, 188  
 incinerators 231, 233  
 indirect evaporative cooling (-er) 61,  
   62, 91  
 inductive load 196  
 industrial process heating 209  
 inert gas 54  
 infiltration 40, 66  
 information content (of noise) 154  
 infrared 8, 25, 79  
 infra-sound 152  
 insect screen 65  
 installed flux 135  
 insulating materials 8  
   shutters 55  
 insulation **42**  
 integration, of hardware 93  
   of daylight 113, 140, 141  
   in performance 92  
 intelligent buildings 91  
 intensity (luminous) 100, 132, 133  
 intensity (sound) 146, 148  
 inter-generational equity 234, 237  
 intermediate sky 109  
 intermittent heating 66  
 internal heat gain 34, 41, 62  
 internally reflected component (IRC)  
   116, 119, 288  
 interpretation (of sounds) 152  
 interruptible supply (of electricity)  
   226  
 interstitial condensation 72  
 inverse square law 102, 148  
 inversion (temperature) 73  
 irradiance 12, 25, 26, 28, 37  
 irradiation 25, 26, 28, 29, 37
- katabatic wind 73  
 kinetic energy 193
- lamp **126**, 127  
   holder 130  
   lumens 128, 295



- laser-grooved acrylic sheet 124
- latent heat 6, 13
- leakage (gas) 221
- life cycle cost (LCC) 225, 242
- light 25, 97
  - emitting diode (LED) 128
  - output ratio (LOR) 130
  - shelves 124
  - source 100, 295
  - tubes 125
- linear heat loss coefficient 52
- liquid fuels 217
  - wastes 231
- liquefied petroleum gas (LPG) 202
- load shedding systems 226
- local heating 77
  - time 24
- lococentric (view) 23
- long life/loose fit/low energy
  - movement 234
- loudness level 150
- low emittance (low-e) 54
- low level system (of speakers) 184
- lumen 101
  - method 134
  - output 132, 131, 295
- luminaire 126, 130, 131, 136, 220
- luminance 102
  - distribution 108
  - limit method 139
  - ratio 108, 111, 137
- luminous efficacy 102, 127, 129
  - flux 101
  - intensity 100
- lux 102
  
- maintenance factor (daylighting) 114, 119
- maintenance factor (electric lighting) 135
- masking noise 187
- mass effect (thermal) 48, 51, 55, 57, 58
- mass law (sound) 163, 175
- materials selection 237
- mean radiant temperature (MRT) 18, 68
- mean spherical illuminance 110
- mechanical energy 193
  - to electrical conversion 200
- membrane absorbers 173
- memory 105
- mercury lamps 128
- met 18, 21
- metabolic rate 17, 18
- methane gas 206, 232, 233
- microclimate 75
- microphone 145, 183
  
- model energy code 224
- models 120
- model studies 121
- moisture (content) 8, 72
  - transfer wheel 91
- molecular absorption (of sound) 148, 161, 302
- monitor roof 285
- monochromatic light 97
- Montreal protocol 79, 234
- multi-channel reverberation (MCR)
  - system 186
- Munsell system 100
  
- natural gas 215, 217
- near field 179
- neutrality temperature 20, 22
- neutrons 198
- night flush 91
  - ventilation 58
- noise 153
  - barriers 167
  - climate 158
  - climate indices 159
  - criteria (NC) 154
  - effects 153
  - exposure 153
  - insulation 166
  - and number index (NNR) 160
  - rating (NR) 154, 156, 301
- nomogram (adding sound levels) 150
- nomogram (IRC) 119, 288
- north-light 111
- nuclear energy 197, 198
  - reactors 198
  
- occupational noise 154
- ocean energy 212
- ocean-thermal energy (OTE) 212
- octave band 147
  - filter 147, 187
- octave-band analysis 154
- off-peak tariff 225
- oil 215
  - embargo 233
  - heaters 78
  - production 196
  - reserves 196
- one-dimensional heat flow 44
- opaque elements 38, 104
- open cycle systems 91
- open window unit 171
- operational energy 236
- optical acoustics 180
  - fibres 126
- orbit 22, 23
- organic fluid 211
  
- orientation (ORI) 36, 64, 65, 69, 73, 142
- orthographic (projection) 24
- ossicles 152
- overall thermal transfer value (OTTV) 222
- overcast sky 108, 115
- overheating 34
- overload capacity 77
- overshadowing 112, 296
  
- packaged units (in air conditioning) 88
- panel radiator 79, 83, 209
- parabolic reflector 130, 209
- parasitic energy 207
- passive control (of heat flows) 51, 76
  - dehumidification 73
  - solar heating 51, 55, 57
  - systems 207
- pattern recognition 152
- paved surfaces 161
- pepper-pot diagram 119, 290
- perceived noise level (PnDB) 160
- perception psychology 49
- perforated panel absorbers 174
- performance integration 92
- pergola 75
- perihelion 22
- periodic heat flow 45
- permanent supplementary artificial lighting of the interior (PSALI) 140
- permeability 72, 260
- permeance 72, 260
- perspective (projection) 120, 297
- phase lag 128
- phon 150
- photometry 100
- photopic vision 104
- photosynthesis 199
- photovoltaic (PV) cells 200, 211
- physiological cooling 40, 65, 69
- pink noise 187
- pistol shot 187
- pitch 146, 153
- planar illuminance 110
- plant response 92
- plastic foam (insulation) 43
- plumbing 230
- point-by-point method 134
- point-scoring method 222
- polar curves (for luminaires) 131, 132, 133, 294
  - (sound directionality) 157, 158
- ponds 68
- porous absorbers 172, 175
- position index 137

- potable water 229  
 potential energy 194  
 power (energy flow rate) 5  
   (sound source) 146, 148  
   density 25  
   factor 127, 132, 196  
   stations 200, 231  
   tower 211  
 precipitation 28  
 prefixes (in the SI) 193  
 present worth 242, 314  
 pressure 5  
 pressure (sound) 146  
 pressure zones 69  
 precipitation 28, 228  
 primary energy 215  
 prismatic glass 124  
 process energy requirement (PER) 236  
 progressive rake 179, 312  
 psychological effects (of noise) 188  
 psychrometer 12  
 psychrometric chart 12, 14, 15  
   plot 51  
 psychrometry 12–15  
 public address system 185  
   good 235  
 pump-back systems 226  
 pupil 105  
 pure tone sound 146, 150, 154
- quick response building 77
- radiant cooling 68  
   emission (E) 39  
 radiation 8, 11, 17  
 radiator panels 82  
 radioactive waste 198  
 radioactivity 199  
 radon 66  
 rainfall 29, 228  
 raked floor 179, 312  
 recycling 233  
 reflectance (-ed) 11, 38, 104  
 reflected (sound) 171  
   component (of solar radiation) 37  
 reflection (specular, diffuse, spread)  
   104  
 reflective foil 42, 43  
   glass 124  
   insulation 42, 64  
 refrigerant 79, 209  
 regulatory authorities (requirements)  
   67, 234  
 rehabilitation 235  
 relative humidity 12  
 renewable energy 197, 198, 203  
 resistance (thermal) (R) 10, 41, 51, 72  
   (electrical) 195  
 resistive insulation 43, 64  
   load (electrical) 195  
 resonance 163, 164  
 resonant frequency 165, 173  
 response (to stimulus) 149  
 response factor 58  
 retina 104  
 reverberant room 187  
   sound 171, 177  
 reverberation time 177, 181, 182, 187,  
   310  
 reversible chemical reactions 215  
 Rio declaration 234  
 risk minimisation 221  
 rock-bed storage 208, 209  
 rods 104  
 rollover 196  
 roof lights 115  
   water 228, 239  
 room acoustics 176  
   contents 181  
   index 135  
   volume 180  
 root-mean-square (RMS) 146  
 rotary heat exchanger 91  
 running costs 241  
 R-value 51, 67
- Sabine 177  
 salt production 205  
 saturation humidity 12  
   glare 107  
   line 12  
 Savonius rotor 204  
 saw-tooth roof 284  
 scalar illuminance 110  
 scotopic vision 104  
 screen 75  
 second law (of thermodynamics)  
   6, 202  
 secondary energy 215, 218  
 selective surfaces 11, 68, 86, 207  
 sensible heat 13  
 sensitivity (to sound) 150  
 septic tank 232  
 service pipe 220  
 service water storage 229, 230  
 sewage system 232  
   treatment 206  
 shading 35, 64  
   design 35  
   device 35, 65  
   mask 35, 36  
 shadow angle 35  
 shallow wells 228  
 shed roof 284
- shock protection 219  
 side-lighting 113  
 signal 153  
 silencer 176  
 silicon, amorphous 211  
   polycrystalline cells 211  
   single crystal cells 211  
 simulation programs 49, 221  
 single phase (electrical supply) 218  
   wire earth return (SWER) 201  
 sink (heat) 69, 79, 80, 202  
 site 235  
   survey (overshadowing) 113, 296  
 Skinner 189  
 sky component (SC) 116  
 skylights 50  
 skytherm roof 208  
 slope 73  
 sodium lamps 128  
 sol-air temperature 39, 47  
 solar (PV) cells 200  
   chart *see* sun-path diagram  
   chimney 16  
   collectors 209, 210  
   constant 26  
   control 35, 142  
   energy 205, 213, 228  
   gain factor ( $\theta$ ) 37, 38, 39, 47, 258  
   geometry 22, 270  
   heat gain 34, 37, 63  
   heat gain coefficient (SHGC) 38  
   ponds 211  
   radiation 25, 28, 37, 73, 199, 276  
   -thermal-electrical system (STE) 211  
   time 24  
   water heaters 86, 87, 207  
 solid angle 18, 137  
 solid fuels 78, 217  
 solid wastes 233  
 sound 145  
   diffusion 177, 182  
   field 177  
   level 149, 183  
     intensity level 149  
     pressure level 149  
   meter 187  
   power 148, 184  
   reduction index (SRI) 162  
   reinforcement 183  
   transmission 161  
 sounding board 180  
 source (heat, energy) 79, 80, 202  
   (light) 108, 126, 127  
   (sound) 145, 146  
   intensity 100  
 space heating 209  
 specific heat (capacity) 6, 248

- specific volume 13  
 spectral analysis 168, 169  
   composition 99  
   reverberation times 187  
 spectrum (light) 97, 128  
   (sound) 147, 152, 153, 154, 157  
 specular reflection 104  
 speech interference level (SIL)  
   177, 301  
 split flux method 116  
 split units (in air conditioning) 88  
 spotlight 130, 133  
 spread reflection 104  
 stack effect 14, 16, 60, 268  
 standard effective temperature (SET)  
   21, 22  
 standing waves 177, 178  
 star rating 221  
 starter 132  
 static index 197  
 statistical indices (sound) 159  
 status point 13  
 steady state (heat flow) 34, 41  
 steradian 18, 101, 102  
 stereographic (projection) 24  
 Stevenson screen 28  
 stimulus 149  
 Stockholm conference 233  
 stormwater (run-off) 76, 239  
 stress 5  
 structural discontinuity (sound  
   insulation) 171  
 structural storage (of heat) 91  
 structureborne sound 145, 169, 170,  
   176  
 suitability (of lighting) 106  
 sulphuric rains 231  
 sun 22  
   light 108, 123  
   path diagram 24, 25, 36, 272  
 sunshine duration 26, 28  
 superheated steam 209  
 supplementary lighting 140  
 supply (plenum) system (ventilation)  
   87  
   side management (SSM) 201, 226  
   voltage 218  
 surface colours 99  
   density 46, 163, 167, 171, 173  
   qualities 64  
   resistance (for heat flow) 42  
   temperature 72, 75  
   -to-volume ratio 64, 66  
 sustainability 132, 142, 233, 234, 235,  
   238, 241  
 swing (in heat flow rate) 46, 47, 48  
 système international (SI) 5, 193  
 tapping machine 188  
 target U-value method 223  
 temperate (moderate) climates 32, 33,  
   51, 66  
 temperature 6, 28, 29, 72  
   difference 40–42  
   gradient 44, 162, 266  
   (effect on sound) 161  
   (scale, interval) 5  
 test reference year (TRY) 30  
 thermal applications (of solar energy)  
   207  
   balance 16, 34  
   bridge 44, 52, 53, 72, 256  
   capacity 46  
   comfort 16, 17, 21  
   inertia index 281  
   mass 68  
   to mechanical energy conversion  
     200  
   neutrality (see also neutrality  
     temperature) 22  
   response simulation 49  
   system 34  
 thermic diode 208  
 thermodynamics (first law, second  
   law) 6  
 thermo-luminescence 127  
 thermoplastic sheathed (TPS) cable  
   219  
 thermosiphon 82, 86, 207, 208  
 three-colour theory 97  
   phase supply (electricity) 218  
 threshold of audibility 152  
   of pain 152  
 tidal energy 212  
 tilt angle (TIL) 36, 209  
 timber drying 209  
 timbre 153  
 time constant 281  
 time delays (acoustics) 185  
 time lag 45, 47, 48, 252, 254, 281  
 time-of-day tariffs 226  
 titanium oxide 212  
 top-lighting 113  
 topography 73  
 top-soil 235  
 total absorption (sound) 172, 180, 306  
 total flux method 114, 134  
 town gas 217  
 traffic noise 157, 160, 308  
 traffic noise index 160  
 transducer 145  
 transformers 201, 218  
 translucent 104  
 transmission (electricity) 201  
   coefficient (noise) 162  
   loss (sound) 162, 303, 307  
   test facility 188  
 transmittance, -ed (light, radiation)  
   38, 104  
   (thermal) *see also* U-value 9, 72, 171  
 transmitted (sound) 162  
 transparent 104  
   elements 37  
 tree-belts 167  
 triple bottom line 242  
 Trombe-Michel wall 56, 208  
 tungsten 127  
   -halogen 127  
 turbines 200, 214  
 two-part tariff 226  
 typical meteorological year (TMY) 30  
  
 ultra-sound 152  
 ultraviolet (UV) 8, 25, 128  
 underheating 33  
 uniformity 134  
 uranium 198  
 urban heat islands 74, 75  
 utilisation factor (electric lighting)  
   135, 292  
   daylighting 114, 284  
 U-value 10, 41, 46, 51, 53, 66, 67, 252,  
   254  
  
 value (Munsell) 100  
 vapour pressure 12, 22, 70, 72  
   gradient 266  
   resistance 72  
 variable absorbers (acoustics) 181  
 variable air volume (VAV) system 89  
 vasoconstriction 19  
 vasodilation 19  
 vasomotor adjustments 19  
 vector/scalar ratio 110  
 vegetation 75  
 velocity 5  
   (of air flow) 14, 30, 31  
   (of sound) 145  
   (of light) 97  
 ventilation 40, 65, 72, 87, 176  
   conductance 40  
   heat gain (or loss) 34, 63  
   requirements 40, 264  
 vertical axis wind turbine (VAWT)  
   204, 205  
   shading device 35  
 view angle 132  
 visual acuity 105  
   efficiency 106  
   performance 105, 106  
   task 138

- volume flow (ventilation) rate 40
- vplf (V) 195
  
- wanted sound 177
- warm-humid climates 32, 34, 51, 68
- waste(-s) 231, 238
  - heat 202
- water 227
  - consumption 227
  - reservoirs 228
  - spray 68
  - supply installations 229, 230
  - treatment 229
  
- watt method 134
- wave energy 212
- wave front (acoustics) 148, 161
- wavelength (of light) 97
  - (of sound) 145
- weather 22
  - year for energy calculations (WYEC) 30
- weighting (-ed) (sound level) 151, 156
- wet bulb depression 13
  - temperature (WBT) 13, 61
- white noise 153, 187
- whole house fan (attic fan) 58
- wind 28, 30
  
- effect (in cooling, ventilation) 16, 269
- effect (on sound) 161
- energy 203
- frequency analysis 31
- rose 30, 31
- turbines 204, 205
- window 36, 65
- wing wall 69
- work 5
  - performance 154
  
- zone, zoning (in building) 90





# Architectural Press

An imprint of Elsevier  
[www.architecturalpress.com](http://www.architecturalpress.com)

**Visit [www.architecturalpress.com](http://www.architecturalpress.com)**

Our regularly updated website includes:

- News on our latest books
- Special offers, discounts and freebies
- Free downloadable sample chapters from our newest titles
- Links to companion websites giving you extra information on our books
- Author biographies and information
- Links to useful websites and extensive directories of relevant organisations and publications
- A search engine and a secure online ordering system for the entire catalogue of **Architectural Press** books



You can also get **free membership** of our **eNews** service by visiting our website to register. Once you are a member, you will receive a monthly email bulletin which gives you:

- Exclusive author articles
- The chance to enter prize draws for free books
- Access to offers and discounts exclusive to **eNews** members
- News of our latest books sent direct to your desktop

If you would like any other information about [www.architecturalpress.com](http://www.architecturalpress.com) or our **eNews** service please contact:

Rachel Lace, Product Manager  
Email: [r.lace@elsevier.com](mailto:r.lace@elsevier.com)  
Tel: +44 (0) 1865 314594  
Fax: +44 (0)1865 314572

Address: Architectural Press, Linacre House, Jordan Hill, Oxford, OX2 8DP, UK

